

Unitronics' UniStream® PLCs are DIN-rail mounted Programmable Logic Controllers (PLCs) with a built-in I/O configuration.

UniStream connects directly to UniCloud, Unitronics' IIoT cloud platform using built-in UniCloud connectivity. More information about UniCloud is available at [www.unitronics.cloud](http://www.unitronics.cloud).

### Model numbers in this document

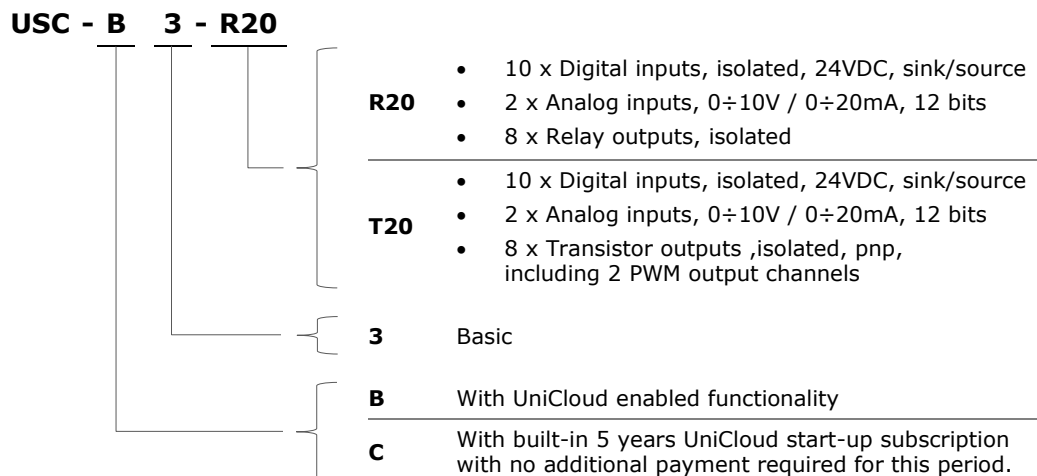

Installation Guides are available in the Unitronics Technical Library at [www.unitronicsplc.com](http://www.unitronicsplc.com).

Power Supply	USC-x3-R20	USC-x3-T20
Input voltage	24VDC	24VDC
Permissible range	20.4VDC to 28.8VDC	20.4VDC to 28.8VDC
Max. current consumption	0.37A@24VDC	0.33A@24VDC
Isolation	None	

General	
I/O support	
Built-in I/O	According to model
Local Uni-I/O™ support	No
Remote I/O	Support 1 UniStream Remote I/O Adapter (URB)
Communication ports	
Built-in COM ports	Specifications are provided below in the section Communications
Add-on Ports	Add up to 2 ports to a single controller using Uni-COM™ UAC-CB Modules <sup>(1)</sup>

Internal memory	RAM: 256MB ROM: 3GB system memory 1GB user memory
Ladder memory	1 MB
External memory	No
Bit operation	0.13 $\mu$ s
Battery	Model: 3V CR2032 Lithium battery <sup>(2)</sup> Battery lifetime: 4 years typical, at 25°C Battery Low detection and indication (via BATT. LOW indicator and via System Tag).

**Communication (Built-in Ports)**

Ethernet ports	
Number of ports	2
Port type	10/100 Base-T (RJ45)
Auto crossover	Yes
Auto negotiation	Yes
Isolation voltage	500VAC for 1 minute
Cable	Shielded CAT-5e cable, up to 100 m (328 ft)
USB host	
Number of ports	1
Port type	Type A
Data rate	USB 2.0 (480Mbps)
Isolation	None
Cable	USB 2.0 compliant; < 3 m (9.84 ft)
Over current protection	Yes

**Digital Inputs**

Number of inputs	10
Type	Sink or Source
Isolation voltage	
Input to bus	500VAC for 1 minute
Input to input	None
Nominal voltage	24VDC @ 6mA
Input voltage	
Sink/Source	On state: 15-30VDC, 4mA min. Off state: 0-5VDC, 1mA max.
Nominal impedance	4k $\Omega$
Filter	6ms typical

<b>Analog Inputs</b>					
Number of inputs	2				
Input range <sup>(3)</sup> <sup>(4)</sup>	<b>Input Type</b>	<b>Nominal Values</b>		<b>Over-range Values *</b>	
	0 ÷ 10VDC	0 ≤ Vin ≤ 10VDC		10 < Vin ≤ 10.15VDC	
	0 ÷ 20mA	0 ≤ Iin ≤ 20mA		20 < Iin ≤ 20.3mA	
	* <b>Overflow</b> <sup>(5)</sup> is declared when an input value exceeds the Over-range boundary.				
Absolute maximum rating	±30V (Voltage), ±30mA (Current)				
Isolation	None				
Conversion method	Successive approximation				
Resolution	12 bits				
Accuracy (25°C / -20°C to 55°C)	±0.3% / ±0.9% of full scale				
Input impedance	541kΩ (Voltage), 248Ω (Current)				
Noise rejection	10Hz, 50Hz, 60Hz, 400Hz				
Step response <sup>(6)</sup> (0 to 100% of final value)	<b>Smoothing</b>	<b>Noise Rejection Frequency</b>			
		400Hz	60Hz	50Hz	10Hz
	None	2.7ms	16.86ms	20.2ms	100.2ms
	Weak	10.2ms	66.86ms	80.2ms	400.2ms
	Medium	20.2ms	133.53ms	160.2ms	800.2ms
Strong	40.2ms	266.86ms	320.2ms	1600.2ms	
Update time <sup>(6)</sup>	<b>Noise Rejection Frequency</b>		<b>Update Time</b>		
	400Hz		5ms		
	60Hz		4.17ms		
	50Hz		5ms		
10Hz		10ms			
Operational signal range (signal + common mode)	Voltage mode – AIX: -1V ÷ 10.5V ; CM1: -1V ÷ 0.5V Current mode – AIX: -1V ÷ 5.5V ; CM1: -1V ÷ 0.5V (x=0 or 1)				
Cable	Shielded twisted pair				
Diagnostics <sup>(5)</sup>	Analog input overflow				

<b>Relay Outputs (USC-x3-R20)</b>	
Number of outputs	8 (O0 to O7)
Output type	Relay, SPST-NO (Form A)
Isolation groups	Two groups of 4 outputs each

Isolation voltage	
Group to bus	1,500VAC for 1 minute
Group to group	1,500VAC for 1 minute
Output to output within group	None
Current	2A maximum per output (Resistive load)
Voltage	250VAC / 30VDC maximum
Minimum load	1mA, 5VDC
Switching time	10ms maximum
Short-circuit protection	None
Life expectancy <sup>(7)</sup>	100k operations at maximum load

**Transistor Outputs (USC-x3-T20)**

Number of outputs	8
Output type	Transistor, Source (pnp)
Isolation voltage	
Output to bus	500VAC for 1 minute
Output to output	None
Outputs power supply to bus	500VAC for 1 minute
Outputs power supply to output	None
Current	0.5A maximum per output
Voltage	See Source Transistor Outputs Power Supply specification below
ON state voltage drop	0.5V maximum
OFF state leakage current	10µA maximum
Switching times	Turn-on/off: 80µs maximum, Turn-off: 155µs maximum (Load resistance < 4kΩ)
PWM Frequency <sup>(8)</sup>	O0, O1: 3kHz max. (Load resistance < 4kΩ)
Short-circuit protection	Yes

**Transistor Outputs Power Supply (USC-x3-T20)**

Nominal operating voltage	24VDC
Operating voltage	20.4 – 28.8VDC
Maximum current consumption	30mA@24VDC Current consumption does not include load current

<b>LED Indications</b>				
<b>I/O LEDs</b>	<b>Color</b>	<b>Indication</b>		
Digital Input	Green	Input state		
Analog Input	Red	On: Input value is in Overflow		
Relay and Transistor Output	Green	Output state		
<b>Status LEDs</b>	<b>Color &amp; State</b>		<b>Indication</b>	
RUN	Green	On	Run mode	
		Blink	This indication is in conjunction with the USB LED. See table below, USB Actions Indications, for details	
	Orange	On	Start-up mode	
		Blink	Stop mode	
ERROR	Red	On/Blink	The Error LED can give indications in conjunction with the RUN and/or USB LED. See the next tables Error Indication and USB Actions Indications for details	
USB	Green	On	A USB drive is detected that contains valid action file(s). See table below, USB Actions Indications, for details	
		Blink	USB Action in progress	
BATT. LOW	Red	On	Battery is low or missing	
FORCE	Red	On	I/O Force on	
<b>Error Indications</b>	<b>LED, Color &amp; State</b>			
	<b>RUN</b>	<b>ERROR</b>	<b>USB</b>	<b>Indication</b>
		Red blink	Off	USB Action has failed – disconnect the USB drive to dismiss the error
		Red blink		HW Configuration Mismatch – the HWC in the UniLogic application does not match the Uni-I/O modules physically connected to the PLC
	Orange blink	Red blink		Application Invalid or Version Mismatch (UniLogic version is not supported by device firmware)
		Red On		Uni-I/O Error (check wiring connections)
	Orange blink	Red On		OS/Application error

USB Actions Indications	LED, Color & State			Indication
	RUN	ERROR	USB	
			Green On	USB drive detected with valid Action file(s) - press CONFIRM <sup>(9)</sup> to start Action or USB Action finished successfully.
			Green blink	USB Action in progress.
	Green blink		Green On	USB Action requires reset; press CONFIRM to restart system
		Red blink	Green Off	USB drive detected, but contains corrupt Action file(s)
		Red blink	Green ON	USB Action ran with error – disconnect the USB drive to dismiss the error.

Environmental	
Protection	IP20, NEMA1
Operating temperature	-20°C to 55°C (-4°F to 131°F)
Storage temperature	-30°C to 70°C (-22°F to 158°F)
Relative Humidity (RH)	5% to 95% (non-condensing)
Operating Altitude	2,000 m (6,562 ft)
Shock	IEC 60068-2-27, 15G, 11ms duration
Vibration	IEC 60068-2-6, 5Hz to 8.4Hz, 3.5mm constant amplitude, 8.4Hz to 150Hz, 1G acceleration

Dimensions		
	Weight	Size
<b>USC-x3-R20</b>	0.36 Kg (0.79 lb)	As shown in the images below
<b>USC-x3-T20</b>	0.35 Kg (0.77 lb)	

**Mechanical Dimensions**

*Front View*

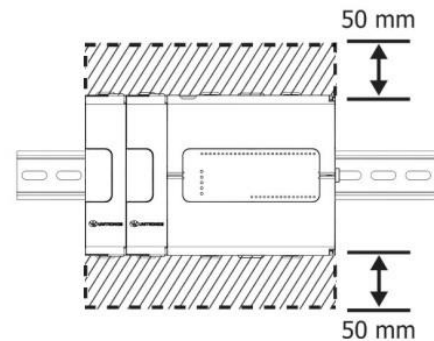
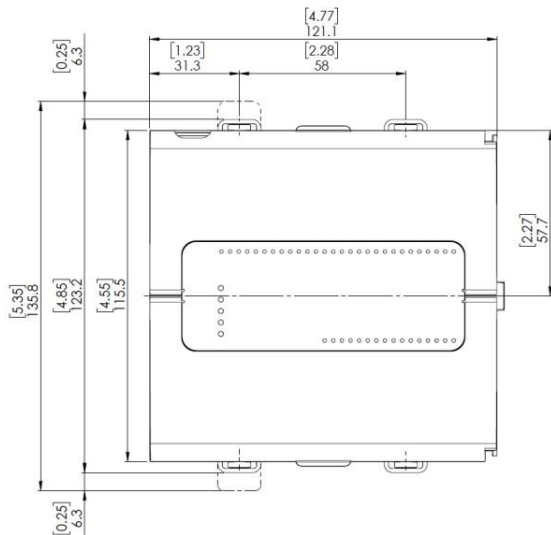

*Bottom View*

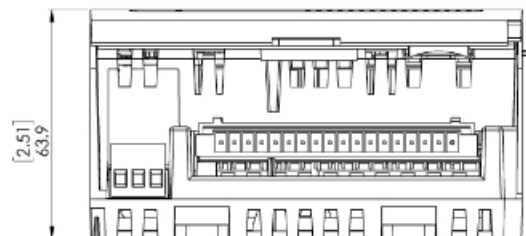

**Notes:**

1. Uni-COM™ CB modules plug directly into the Uni-COM Jack on the side of the controller. This controller supports Uni-COM modules as follows:
  - One serial module
  - One CANbus module, which may be followed by a single serial module.
 For more information, refer to the product's installation guide.
2. When replacing the unit's battery, make sure that the new one has environmental specifications that are similar or better than the one specified in this document.
3. The 4-20mA input option is implemented using 0-20mA input range.
4. The analog inputs measure values that are slightly higher than the nominal input range (Input Over-range).  
 Note that when the input overflow occurs, it is indicated in the corresponding I/O Status tag as well as by the respective input LED (see LED Indications), while the input value is registered as the maximum permissible value. For example, if the specified input range is 0 ÷ 10V, the Over-range values can reach up to 10.15V, and any input voltage higher than that will still register as 10.15V while the Overflow system tag is turned on.
5. See LED Indications Table for description of the relevant indications. Note that the diagnostics results are also indicated in the system tags and can be observed through the UniApps™ or the online state of the UniLogic®.
6. Step response and update time are independent of the number of channels that are used.
7. Life expectancy of the relay contacts depends on the application that they are used in. The product's installation guide provides procedures for using the contacts with long cables or with inductive loads.
8. Outputs O0 and O1 can be configured as either normal digital outputs or as PWM outputs. PWM outputs specifications apply only when outputs are configured as PWM outputs.
9. This refers to the CONFIRM button on the controller USB Actions; press it if the indication requires.

The information in this document reflects products at the date of printing. Unitronics reserves the right, subject to all applicable laws, at any time, at its sole discretion, and without notice, to discontinue or change the features, designs, materials and other specifications of its products, and to either permanently or temporarily withdraw any of the forgoing from the market.

All information in this document is provided "as is" without warranty of any kind, either expressed or implied, including but not limited to any implied warranties of merchantability, fitness for a particular purpose, or non-infringement. Unitronics assumes no responsibility for errors or omissions in the information presented in this document. In no event shall Unitronics be liable for any special, incidental, indirect or consequential damages of any kind, or any damages whatsoever arising out of or in connection with the use or performance of this information.

The tradenames, trademarks, logos and service marks presented in this document, including their design, are the property of Unitronics (1989) (R"G) Ltd. or other third parties and you are not permitted to use them without the prior written consent of Unitronics or such third party as may own them.

DOC32007-A6 REV.A01 12/20