



# Inxpect SRE 200 Series

**SRE - Safety Radar Equipment**

---

9 meters range sensors

---

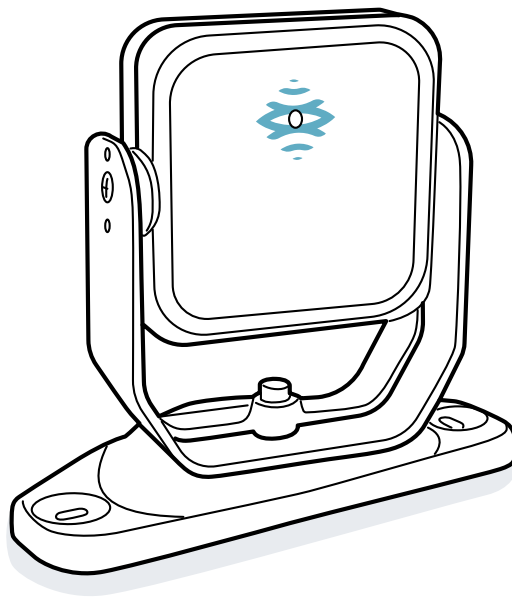

**Instruction manual  
v1.4 - EN**

Original instructions



**WARNING!** Anyone who uses this system must read the instruction manual to ensure safety. Read and adhere to the "Safety information" chapter in its entirety before using the system for the first time.

Copyright © 2021-2023, Inxpect SpA

All rights reserved in all countries.

Any distribution, alteration, translation or reproduction, partial or total, of this document is strictly prohibited unless with prior authorization in writing from Inxpect SpA, with the following exceptions:

- Printing the document in its original format, totally or partially.
- Transferring the document on websites or other electronic systems.
- Copying contents without any modification and stating Inxpect SpA as copyright owner.

Inxpect SpA reserves the right to make modifications or improvements to the relative documentation without prior notice.

Requests for authorizations, additional copies of this manual or technical information about this manual must be addressed to:

Inxpect SpA  
Via Serpente, 91  
25131 Brescia (BS)  
Italy  
safety-support@inxpect.com  
+39 030 5785105

# Contents

<b>Glossary of terms</b> .....	<b>v</b>
<b>1. This manual</b> .....	<b>7</b>
1.1 Information on this manual .....	7
<b>2. Safety</b> .....	<b>11</b>
2.1 Safety information .....	11
2.2 Conformity .....	14
<b>3. Get to know Inxpect SRE 200 Series</b> .....	<b>15</b>
3.1 Inxpect SRE 200 Series .....	15
3.2 Control units .....	17
3.3 Control unit inputs .....	22
3.4 Control unit outputs .....	23
3.5 Sensors .....	27
3.6 Inxpect Safety application .....	29
3.7 Fieldbus communication (PROFIsafe) .....	31
3.8 Fieldbus communication (Safety over EtherCAT® - FSoE) .....	32
3.9 MODBUS communication .....	33
3.10 System configuration .....	34
<b>4. Functioning principles</b> .....	<b>37</b>
4.1 Sensor functioning principles .....	37
4.2 Detection fields .....	37
<b>5. Safety functions</b> .....	<b>42</b>
5.1 Safety working modes and safety functions .....	42
5.2 Safety working mode: Access detection and restart prevention (default) .....	43
5.3 Safety working mode: Always-on access detection .....	44
5.4 Custom target detection .....	44
5.5 Restart prevention function: static object detection option .....	45
5.6 Features of the restart prevention function .....	46
<b>6. Other functions</b> .....	<b>48</b>
6.1 Muting .....	48
6.2 Anti-tampering functions: anti-rotation around axes .....	49
6.3 Anti-tampering functions: anti-masking .....	50
6.4 Auto-resume (5.x sensors only) .....	52
6.5 Electromagnetic Robustness .....	52
<b>7. Sensor position</b> .....	<b>53</b>
7.1 Basic concepts .....	53
7.2 Sensor field of view .....	53
7.3 Advanced field of view (5.x sensors only) .....	57
7.4 Dangerous area calculation .....	58
7.5 Calculation of range of distances .....	60
7.6 Sensor position recommendations .....	61
7.7 Installations on moving elements (Mobile application) .....	63
7.8 Outdoor installations .....	64
<b>8. Installation and use procedures</b> .....	<b>65</b>
8.1 Before installation .....	65
8.2 Install Inxpect SRE 200 Series .....	65
8.3 Set the sensor inclination with a 1° precision .....	73
8.4 Configure Inxpect SRE 200 Series .....	76
8.5 Validate the safety functions .....	78
8.6 Manage the configuration .....	82
8.7 Other procedures .....	83
<b>9. Troubleshooting</b> .....	<b>85</b>
9.1 Troubleshooting procedures .....	85
9.2 Event log management .....	88
9.3 INFO events .....	92
9.4 ERROR events (control unit) .....	94
9.5 ERROR events (sensor) .....	96
9.6 ERROR events (CAN bus) .....	98

<b>10. Maintenance</b> .....	<b>99</b>
10.1 Planned maintenance .....	99
10.2 Extraordinary maintenance .....	100
<b>11. Technical references</b> .....	<b>102</b>
11.1 Technical data .....	103
11.2 Terminal blocks and connector pin-outs .....	106
11.3 Electrical connections .....	108
11.4 Configuration application parameters .....	115
11.5 Digital input signals .....	120
<b>12. Appendix</b> .....	<b>130</b>
12.1 System software .....	130
12.2 Disposal .....	131
12.3 Service and warranty .....	131
12.4 Intellectual property .....	132
12.5 Checklist for installing ESPE .....	132

# Glossary of terms

## A

---

### **Activated output (ON-state)**

Output that switches from OFF to ON-state.

### **Angular coverage**

Property of the field of view that corresponds to the coverage on the horizontal plane.

## D

---

### **Dangerous area**

Area to be monitored because it is dangerous for people.

### **Deactivated output (OFF-state)**

Output that switches from ON to OFF-state.

### **Detection distance x**

Depth of the field of view configured for detection field x.

### **Detection field x**

Portion of the field of view of the sensor. Detection field 1 is the field closer to the sensor.

### **Detection signal x**

Output signal that describes the monitoring status of the detection field x.

## E

---

### **ESPE (Electro-Sensitive Protective Equipment)**

Device or system of devices used for the safety-related detection of people or parts of the body. ESPEs provide personal protection at machines and plants/systems where there is a risk of physical injury. These devices/systems cause the machine or plant/system to switch over to a safe status before a person is exposed to a dangerous situation.

## F

---

### **Field of view**

Sensor area of vision characterized by a specific angular coverage.

### **Fieldset**

Structure of the field of view which can be composed of up to four detection fields.

### **FMCW**

Frequency Modulated Continuous Wave

## I

---

### **Inclination**

Sensor rotation around the x-axis. The sensor inclination is the angle between a line perpendicular to the sensor and a line parallel to the ground.

## M

---

### **Machinery**

The system for which the dangerous area is monitored.

### **Monitored area**

Area that is monitored by Inxpect SRE 200 Series. It is composed of all the fields of all the sensors.

## O

---

### **OSSD**

Output Signal Switching Device

## R

---

### **RCS**

Radar Cross-Section. Measure of how detectable an object is by radar. It depends, among other factors, on the material, dimension and position of the object.

## T

---

### **Tolerance area**

Area of the field of view where detection or not of a moving object/person depends on the characteristics of the same object itself.

# 1. This manual

## 1.1 Information on this manual

### 1.1.1 Objectives of this instruction manual

This manual explains how to integrate Inxpect SRE 200 Series with 9 meters range sensors to safeguard the machinery operators and how to install, use and maintain them safely.

This document includes all the information as Safety Manual according to IEC 61508-2/3 Annex D. Please refer in particular to "Safety parameters" on page 103 and to "System software" on page 130.

The functioning and safety of the machinery to which Inxpect SRE 200 Series is connected is out of the scope of this document.

### 1.1.2 Obligations with regard to this manual



**NOTICE:** *this manual is an integral part of the product and must be kept for its entire working life.*

*It must be consulted for all situations related to the life cycle of the product, from its delivery to decommissioning.*

*It must be stored so that it is accessible to operators, in a clean location and in good condition.*

*In the event of manual loss or damage, contact Technical Support (see "Technical Support" on page 131).*

*Always make the manual available for consultation when the equipment is sold.*

### 1.1.3 Provided documentation

Document	Code	Date	Distribution format
Instruction manual - 9 meters range sensors (this manual)	Inxpect SAF-IM-200S_9m_7_00240_en	MAY 2023	online PDF PDF downloadable from the site <a href="https://tools.inxpect.com">https://tools.inxpect.com</a>
Instruction manual - 5 meters range sensors	Inxpect SAF-IM-200S_5m_7_00047_en	MAY 2023	online PDF PDF downloadable from the site <a href="https://tools.inxpect.com">https://tools.inxpect.com</a>
Installation instructions	Inxpect SAF-MI-100S-200S_26000041_7_00046_multi	MAY 2023	printed PDF downloadable from the site <a href="https://tools.inxpect.com">https://tools.inxpect.com</a>
PROFIsafe communication Reference guide	Inxpect 100S_200S PROFIsafe RG_7_00067_en_v19	MAY 2023	online PDF PDF downloadable from the site <a href="https://tools.inxpect.com">https://tools.inxpect.com</a>
FSoE communication Reference guide	Inxpect 100S_200S FSoE RG_7_00237_en	MAY 2023	online PDF PDF downloadable from the site <a href="https://tools.inxpect.com">https://tools.inxpect.com</a>
Modbus communication Reference guide	Inxpect 100S_200S MODBUS RG_7_00075_en	MAY 2023	online PDF PDF downloadable from the site <a href="https://tools.inxpect.com">https://tools.inxpect.com</a>
National configuration addendum	Inxpect 200S National configurations addendum_7_00079_multi	-	online PDF PDF downloadable from the site <a href="https://tools.inxpect.com">https://tools.inxpect.com</a>
RCS Reader Tool instructions	Inxpect 200S RCS Reader Tool user manual_7_00078_en	-	online PDF PDF downloadable from the site <a href="https://tools.inxpect.com">https://tools.inxpect.com</a>
Cable validator	Inxpect 100S_200S Cable Validator tool_7_00066_en	-	online Excel Excel downloadable from the site <a href="https://tools.inxpect.com">https://tools.inxpect.com</a>

## 1.1.4 Instruction manual updates

Publication date	Code	Hardware version	Firmware version	Updates
MAY 2023	Inxpect SAF-IM-200S_9m_7_00240_en_v1.4	<p>Control units:</p> <ul style="list-style-type: none"> <li>Type A: 2.2</li> <li>Type B: 2.4</li> </ul> <p>Sensors:</p> <ul style="list-style-type: none"> <li>S201A model: 2.2</li> <li>S203A model : 1.0</li> </ul>	<p>Control units:</p> <ul style="list-style-type: none"> <li>Type A: 2.0</li> <li>Type B: 2.0</li> </ul> <p>Sensors:</p> <ul style="list-style-type: none"> <li>S201A-MLR: 3.2M</li> <li>S201A-WL: 5.0</li> <li>S203A-WL: 5.0</li> </ul>	<p>Added control units: C201A-F, C201B-P, C201B-F, C202B, C203B.</p> <p>Added sensors: S201A-W, S201A-WL, S203A-W, S203A-WL.</p> <p>Updated procedures in "Validate the safety functions" on page 78.</p> <p>Added sensor configuration error details ("Sensor configuration error (SENSOR CONFIGURATION ERROR)" on page 96.</p> <p>Added multi-user management for the Inxpect Safety application.</p> <p>Changed name of digital input function: Activate dynamic configuration &gt; Dynamic configuration switch</p> <p>New input functions: Restart signal on a single channel (cat 2), System recondition on a single channel (cat.2), and Fieldbus controlled on a single channel (cat.2).</p> <p>New inputs options: Redundancy mode, Encoded channel.</p> <p>New output functions: Detection signal group, Fieldbus controlled on a single channel.</p> <p>Updated Factory reset procedure ("Restore factory default settings" on page 83).</p> <p>Added Electromagnetic robustness parameter ("Electromagnetic Robustness" on page 52).</p> <p>Added Static object detection sensitivity.</p> <p>Updated "Dangerous area calculation" on page 58.</p> <p>Added "OSSD diagnostic checks" on page 26.</p> <p>Other minor changes.</p>
APR 2022	SAF-UM-SBVBus-en-v1.3	<ul style="list-style-type: none"> <li>C201A-PNS, C202A and C203A: 2.1</li> <li>S201A: 2.1</li> <li>S201A-MLR: 2.1</li> </ul>	<ul style="list-style-type: none"> <li>C201A-PNS, C202A and C203A: 1.6.0</li> <li>S201A: 3.1</li> <li>S201A-MLR: 3.1M</li> </ul>	<p>Changed system, control unit, and sensors denomination.</p> <p>Renamed safety working modes ("Always restart prevention" &gt; "Always-on restart prevention"; "Always access detection" &gt; "Always-on access detection").</p> <p>Added S201A-MLR sensor.</p> <p>Added "Custom target detection" on page 44.</p> <p>Updated standard list in "Standards and Directives" on page 14.</p> <p>Updated the anti-rotation around axes function (disabled by default, can be enabled for each axis of each sensor) in "Anti-tampering functions: anti-rotation around axes" on page 49.</p> <p>Updated the anti-masking function (can be disabled for each axis of each sensor) in "Anti-tampering functions: anti-masking" on page 50.</p> <p>Updated parameters list and organization in "Configuration application parameters" on page 115.</p> <p>Updated K value in "Formula for stationary application" on page 58.</p> <p>Minor changes.</p>
DEC 2021	SAF-UM-SBVBus-en-v1.2	<ul style="list-style-type: none"> <li>C201A-PNS, C202A and C203A: 2.1</li> <li>S201A: 2.1</li> </ul>	<ul style="list-style-type: none"> <li>C201A-PNS, C202A and C203A: 1.5.0</li> <li>S201A: 3.0</li> </ul>	<p>Added static object detection option</p> <p>Added reference to the "National configuration addendum" document</p> <p>Added "Muting activation conditions" on page 48</p>

**Note:** the firmware of the control unit can be updated through the Inxpect Safety application. The latest firmware version available contains the features described in the manual at the system level. The sensor firmware cannot be updated.



## **1.1.5 Intended users of this instruction manual**

The recipients of the instruction manual are:

- the machinery manufacturer onto which the system will be installed
- system installer
- machinery maintenance technician



# 2. SAFETY

## 2.1 Safety information

### 2.1.1 SAFETY MESSAGES

Warnings related to the safety of the user and of the equipment as envisaged in this document are as follows:



**WARNING!** Indicates a hazardous situation which, if not avoided, may cause death or serious injury.

**NOTICE:** indicates obligations that if not observed may cause harm to the equipment.

### 2.1.2 SAFETY SYMBOLS ON THE PRODUCT



This symbol marked on the product indicates that the manual must be consulted. In particular, pay attention to the following activities:

- wiring of the connections (see "Terminal blocks and connector pin-outs" on page 106 and "Electrical connections" on page 108)
- cable operating temperature (see "Terminal blocks and connector pin-outs" on page 106)
- control unit cover, which was subjected to a low energy impact test (see "Technical data" on page 103)

### 2.1.3 PERSONNEL SKILLS

The recipients of this manual and the skills required for each activity presented herein are as follows:

Recipient	Assignments	Skills
Machinery manufacturer	<ul style="list-style-type: none"><li>• defines which protective devices should be installed and sets the installation specifications</li></ul>	<ul style="list-style-type: none"><li>• knowledge of significant hazards of the machinery that must be reduced based on risk assessment</li><li>• knowledge of the entire machinery safety system and the system on which it is installed</li></ul>
Protection system installer	<ul style="list-style-type: none"><li>• installs the system</li><li>• configures the system</li><li>• prints configuration reports</li></ul>	<ul style="list-style-type: none"><li>• advanced technical knowledge in the electrical and industrial safety fields</li><li>• knowledge of the dimensions of the dangerous area of the machinery to be monitored</li><li>• receives instructions from the machinery manufacturer</li></ul>
Machinery maintenance technician	<ul style="list-style-type: none"><li>• performs maintenance on the system</li></ul>	<ul style="list-style-type: none"><li>• advanced technical knowledge in the electrical and industrial safety fields</li></ul>

### 2.1.4 SAFETY ASSESSMENT

Before using a device, a safety assessment in accordance with the Machinery Directive is required.

The product as an individual component fulfills the functional safety requirements in accordance with the standards stated in "Standards and Directives" on page 14. However, this does not guarantee the functional safety of the overall plant/machine. To achieve the relevant safety level of the overall plant/machine's required safety functions, each safety function needs to be considered separately.

## 2.1.5 INTENDED USE

Inxpect SRE 200 Series is a human body detection system, certified SIL 2 according to IEC/EN 62061, PL d according to EN ISO 13849-1 and Performance Class D according to IEC TS 62998-1.

It performs the following safety functions:

- **Access detection function:**



**WARNING! These safety-related functions work in exclusive mode: with the activation of the Custom target detection, the detection of a human body is no longer guaranteed.**

- access of one or more persons to a hazardous area deactivates the safety outputs to stop the moving parts of the machinery (Human detection), or
- access of one or more targets with an RCS higher than a set threshold to a hazardous area deactivates the safety outputs to stop the moving parts of the machinery (Custom target detection)
- **Restart prevention function:** prevents unexpected starting or restarting of the machinery. Detection of motion within the dangerous area maintains the safety outputs deactivated to prevent machinery starting.

It performs the following additional safety-related functions:

- **Stop signal** (Category 3, according to EN ISO 13849-1): it forces all the safety outputs to OFF-state. Only on C201A and C201B models, it signals a stop request status with a specific safety message on the Fieldbus output interface.
- **Restart signal:** it enables the control unit to switch to ON-state the safety outputs related to all the detection fields with no motion detected. Only on C201A and C201B models, it makes disappear a stop request status with a specific safety message on the Fieldbus output interface. It can be performed:
  - using single channel inputs/OSSDs (Category 2, according to EN ISO 13849-1)
  - using dual channel inputs/OSSDs (Category 3, according to EN ISO 13849-1)
- **Muting** (Category 3, according to EN ISO 13849-1): it inhibits the detection capability of one or a group of sensors (see "Muting" on page 48).
- **Dynamic configuration switch** (Category 3, according to EN ISO 13849-1): it allows the dynamic switch among previously set configurations (see "System configuration" on page 34).
- **Fieldbus controlled:** it monitors the input status through Fieldbus communication. It can be performed:
  - using single channel inputs/OSSDs (Category 2, according to EN ISO 13849-1): it provides the capability to safely redirect the value of the input data exchanged with the Fieldbus master to a physical status of the OSSDs.
  - using dual channel inputs/OSSDs (Category 3, according to EN ISO 13849-1): it provides the capability to safely redirect the status of the digital inputs to the output data exchanged with the Fieldbus master.



**WARNING! the following faults makes the Fieldbus controlled safety-related function unavailable: POWER ERROR, TEMPERATURE ERROR, FIELDBUS ERROR, PERIPHERAL ERROR, FEE ERROR and FLASH ERROR.**



**WARNING! only for Stop signal, Restart signal, Muting and Dynamic configuration switch. Any fault on the sensors or the control unit brings the system to the safe state and makes the safety-related functions unavailable.**

Inxpect SRE 200 Series is suitable for protecting the human body in the following scenarios:

- dangerous area protection in stationary and mobile applications
- indoor and outdoor applications

Inxpect SRE 200 Series meets requirements of applications safety functions that require a risk reduction level of:

- up to SIL 2, HFT = 0 according to IEC/EN 62061
- up to PL d, Category 3 according to EN ISO 13849-1
- up to Performance Class D according to IEC TS 62998-1

Inxpect SRE 200 Series, in combination with additional risk reduction means, can be used for applications safety functions that require higher risk reduction levels.

## 2.1.6 IMPROPER USE

The following is deemed improper use in particular:

- any component, technical or electrical modification to the product
- use of the product outside the areas described in this document
- use of the product outside the technical details, see "Technical data" on page 103

## 2.1.7 EMC-COMPLIANT ELECTRICAL INSTALLATION

**NOTICE:** The product is designed for use in an industrial environment. The product may cause interference if installed in other environments. If installed in other environments, measures should be taken to comply with the applicable standards and directives for the respective installation site with regard to interference.

## 2.1.8 GENERAL WARNINGS

- Incorrect installation and configuration of the system decreases or inhibits the protective function of the system. Follow the instructions provided in this manual for correct installation, configuration and validation of the system.
- Changes to the system configuration may compromise the protective function of the system. After any changes made to the configuration, validate correct functioning of the system by following the instructions provided in this manual.
- If the system configuration allows access to the dangerous area without detection, implement additional safety measures (e.g., guards).
- The presence of static objects, in particular metallic objects, within the field of view may limit the efficiency of sensor detection. Keep the sensor field of view unobstructed.
- The system protection level (SIL 2, PL d) must be compatible with the requirements set forth in the risk assessment.
- Check that the temperature of the areas where the system is stored and installed is compatible with the storage and operating temperatures indicated in the technical data of this manual.
- Radiation from this device does not interfere with pacemakers or other medical devices.

## 2.1.9 WARNINGS FOR THE RESTART PREVENTION FUNCTION

- The restart prevention function is not guaranteed in blind spots. If required by the risk assessment, implement adequate safety measures in those areas.
- Machinery restarting must be enabled only in safe conditions. The button for the restart signal must be installed:
  - outside of the dangerous area
  - not accessible from the dangerous area
  - in a point where the dangerous area is fully visible

## 2.1.10 RESPONSIBILITY

The machinery manufacturer and system installer are responsible for the operations listed below:

- Providing adequate integration of the safety output signals of the system.
- Checking the monitored area of the system and validating it based on the needs of the application and risk assessment.
- Following the instructions provided in this manual.

## 2.1.11 LIMITS

- If the static object detection option is disabled, the system cannot detect the presence of people who are immobile and not breathing or objects within the dangerous area.
- The system does not offer protection from pieces ejected from the machinery, from radiation, and objects falling from above.
- The machinery command must be electronically controlled.

## 2.1.12 DISPOSAL

In safety-related applications, comply with the mission time reported in "General specifications" on page 103. For decommissioning follow the instructions reported in "Disposal" on page 131.

## 2.2 Conformity

### 2.2.1 STANDARDS AND DIRECTIVES

<b>Directives</b>	2006/42/EC (MD - Machinery) 2014/53/EU (RED - Radio equipment)
<b>Harmonized standards</b>	EN ISO 13849-1: 2015 PL d EN ISO 13849-2: 2012 IEC/EN 62061: 2021 ETSI EN 305 550-2 V1.2.1 IEC/EN 61010-1: 2010, A1:2019 ETSI EN 301 489-1 v2.2.3 (only emissions) ETSI EN 301 489-3 v2.1.1 (only emissions) IEC/EN 61000-6-2:2019 IEC/EN 62061: 2005, A1:2013, A2:2015, AC:2010 SIL 2
<b>Non-harmonized standards</b>	IEC/EN 61326-3-1:2017 IEC/EN 61496-1: 2013 (section 5.4.2 and 5.4.4), AC:2015 IEC/EN 61496-1: 2020 (section 5.4.2 and 5.4.4) IEC/EN 61508: 2010 Part 1-7 SIL 2 ETSI EN 305 550-1 V1.2.1 IEC TS 62998-1:2019 UL 61010-1 * CAN/CSA 61010-1 * UL 61496-1 * CRD of IEC 61496-3 * IEC/EN 61784-3-3:2016 for the PROFIsafe Fieldbus IEC/EN 61784-3-12:2010, A1:2019 for FSoE Fieldbus

**Note \***: not valid for S201A-MLR.

**Note**: no type of failure has been excluded during the system analysis and design phase.

All updated certifications can be downloaded from <https://www.inxpect.com/en/downloads>.

### 2.2.2 CE

The manufacturer, Inxpect SpA, states that Inxpect SRE 200 Series (Safety Radar Equipment) complies with the 2014/53/EU and 2006/42/EC directives. The full EU Declaration of Conformity text is available on the company's website: <https://www.inxpect.com/en/downloads>.

### 2.2.3 UKCA

The manufacturer, Inxpect SpA, states that Inxpect SRE 200 Series (Safety Radar Equipment) complies with Radio Equipment Regulations 2017 and Supply of Machinery (Safety) Regulations 2008. The full UKCA Declaration of Conformity text is available on the company's website: <https://www.inxpect.com/en/downloads>.

### 2.2.4 OTHER CONFORMITIES AND NATIONAL CONFIGURATIONS

For a complete, up-to-date list of product conformities and any national configurations, please refer to the National configuration addendum document. The PDF can be downloaded from the site <https://tools.inxpect.com>.

# 3. Get to know Inxpect SRE 200 Series

## Contents

This section includes the following topics:

<b>3.1 Inxpect SRE 200 Series</b> .....	<b>15</b>
<b>3.2 Control units</b> .....	<b>17</b>
<b>3.3 Control unit inputs</b> .....	<b>22</b>
<b>3.4 Control unit outputs</b> .....	<b>23</b>
<b>3.5 Sensors</b> .....	<b>27</b>
<b>3.6 Inxpect Safety application</b> .....	<b>29</b>
<b>3.7 Fieldbus communication (PROFIsafe)</b> .....	<b>31</b>
<b>3.8 Fieldbus communication (Safety over EtherCAT® - FSoE)</b> .....	<b>32</b>
<b>3.9 MODBUS communication</b> .....	<b>33</b>
<b>3.10 System configuration</b> .....	<b>34</b>

## Product label description

The following table describes the information contained in the product label:

Part	Description
<b>SID</b>	Sensor ID
<b>DC</b>	"yy/ww" : year and week of the product manufacture
<b>SRE</b>	Safety Radar Equipment
<b>Model</b>	Product model (e.g., S201A, C201A)
<b>Type</b>	Product variant, used for commercial purposes only
<b>S/N</b>	Serial number

## 3.1 Inxpect SRE 200 Series

### 3.1.1 Definition

Inxpect SRE 200 Series is an active protection radar system that monitors the dangerous areas of machinery.

### 3.1.2 Special features

Some of the special features of this protection system are the following:

- detection of current distance and angle of the targets detected by each sensor
- customization of the detection field with advanced shapes (if available)
- up to four safe detection fields to define different behaviors of the machines
- programmable coverage angle for each detection field
- rotation around three axes during installation to allow better coverage of detection areas
- Safety Fieldbus to safely communicate with the PLC of the machinery (if available)
- possibility to switch dynamically between different preset configurations (max. 32 through Fieldbus, if available, and max. 8 with digital inputs)
- muting on the entire system or only on some sensors
- immunity to dust and smoke
- reduction of undesired alarms caused by the presence of water or processing waste
- communication and data exchange through MODBUS (if available)

### 3.1.3 Main components

Inxpect SRE 200 Series is composed of a control unit and up to six sensors. The Inxpect Safety application allows system operation configuration and checks.

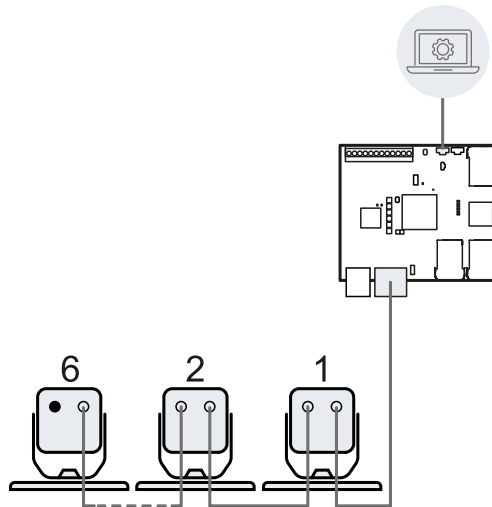

### 3.1.4 Control unit and sensor compatibility

The models and types of control unit and sensors are shown below, with their compatibility.

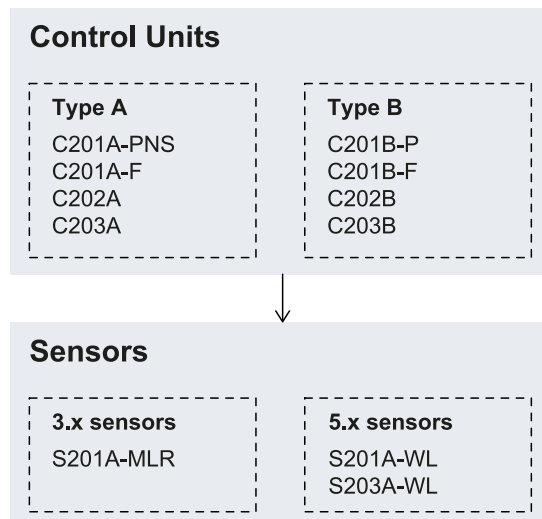

Each control unit, updated to firmware version 2.0.0, can communicate with any sensor.

**NOTICE:** do not connect the control unit with other types of sensors (e.g., 5 meters range sensors).

The control unit can be simultaneously connected to both 3.x sensors and 5.x sensors. For more details about the available features, see "Sensors" on page 27.

### 3.1.5 Control unit - sensor communication

The sensors communicate with the control unit via CAN bus using diagnostic mechanisms in compliance with standard EN 50325-5 to guarantee SIL 2 and PL d.

For correct functioning, each sensor must be assigned an identification number (Node ID).

Sensors on the same bus must have different Node IDs. By default, the sensor does not have a pre-assigned Node ID.



### 3.1.6 Control unit - machinery communication

The control units communicate with the machinery via I/O (see "Control unit inputs" on page 22 and "Control unit outputs" on page 23).

Moreover, according to the model-type, the control unit is provided with:

- a safe communication on a Fieldbus interface. The Fieldbus interface allows the control unit to communicate in real-time with the PLC of the machinery to send information about the system to the PLC (e.g., the position of the detected target) or to receive information from the PLC (e.g., to change the configuration dynamically). For details, see "Fieldbus communication (PROFIsafe)" on page 31 or see "Fieldbus communication (Safety over EtherCAT® - FSoE)" on page 32
- an Ethernet port that allows unsafe communication on a MODBUS interface (see "MODBUS communication" on page 33)

### 3.1.7 Applications

Inxpect SRE 200 Series integrates with the machinery control system: when performing safety functions or detecting failures, Inxpect SRE 200 Series deactivates the safety outputs and keeps them deactivated, so the control system can put the area into a safe condition and/or prevent restarting of the machinery.

In the absence of other control systems, Inxpect SRE 200 Series can be connected to the devices that control the power supply or machinery start-up.

Inxpect SRE 200 Series does not perform normal machinery control functions.

For connection examples, see "Electrical connections" on page 108.

## 3.2 Control units

### 3.2.1 Interfaces

The Inxpect SRE 200 Series supports different control units. The main difference among them is the connection ports, and therefore the communication interfaces available, and the presence of the microSD slot:

	Model	Type	micro-USB port	Ethernet port	Fieldbus port	microSD slot
Type A	C201A	-PNS	x	x	x (PROFIsafe)	-
	C201A	-F	x	x	x (FSoE)	-
	C202A	-	x	x	-	-
	C203A	-	x	-	-	-
Type B	C201B	-P	x	x	x (PROFIsafe)	x
	C201B	-F	x	x	x (FSoE)	x
	C202B	-	x	x	-	x
	C203B	-	x	-	-	x

### 3.2.2 Communication architecture

According to the model-type, this is the communication architecture between the control unit, PLC and PC.

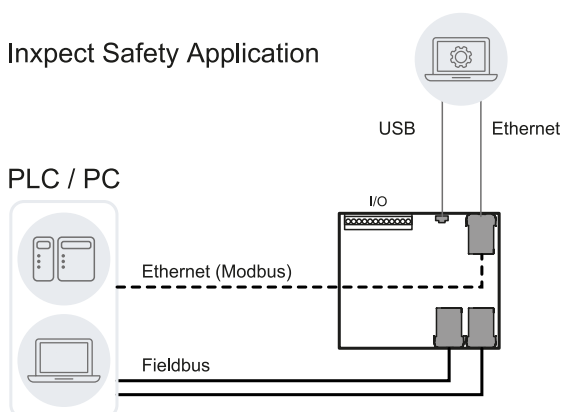

### 3.2.3 Functions

The control unit performs the following functions:

- Collects information from all the sensors via CAN bus.
- Compares the position of detected motion with the set values.
- Deactivates the selected safety output when at least one sensor detects motion in the detection field.
- Deactivates all the safety outputs if a failure is detected in one of the sensors or the control unit.
- Manages the inputs and outputs.
- Communicates with the Inxpect Safety application for all configuration and diagnostic functions.
- Allows dynamically switching between different configurations.
- Communicates with a safety PLC through the safe Fieldbus connection (if available).
- Communicates and exchanges data through MODBUS protocol (if available).
- Performs a backup and a restore system configuration and password to/from microSD card (if available).

### 3.2.4 Type A control units

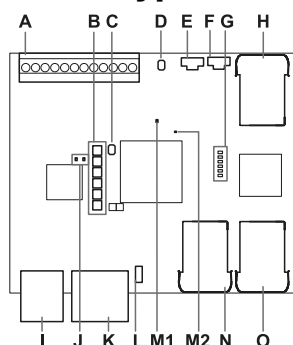

C201A-PNS, C201A-F

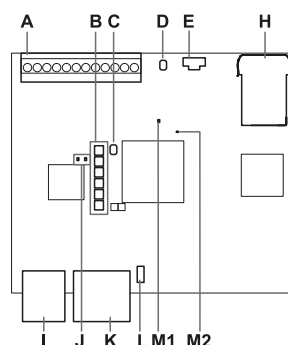

C202A

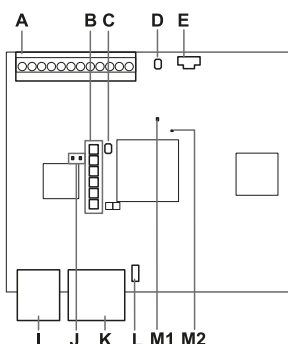

C203A

Part	Description	C201A-PNS	C201A-F	C202A	C203A
A	I/O terminal block	X	X	X	X
B	System status LEDs	X	X	X	X
C	Network parameter reset button / Factory reset button	X	X	X	X
D	Reserved for internal use. Output reset button	X	X	X	X
E	Micro-USB port (micro-B type) for connecting the PC and communicating with the Inxpect Safety application	X	X	X	X
F	Micro-USB port, if mounted (reserved)	X	X	-	-
G	Fieldbus status LEDs See "PROFIsafe Fieldbus status LEDs" on page 20 or "FSoE Fieldbus status LEDs" on page 21.	X	X	-	-

Part	Description	C201A-PNS	C201A-F	C202A	C203A
<b>H</b>	Ethernet port with LEDs for connecting the PC, communicating with the Inxpect Safety application, and for MODBUS communication	X	X	X	-
<b>I</b>	Power supply terminal block	X	X	X	X
<b>J</b>	Power supply LEDs (steady green)	X	X	X	X
<b>K</b>	CAN bus terminal block for connecting the first sensor	X	X	X	X
<b>L</b>	DIP switch to turn on/off the bus termination resistance: <ul style="list-style-type: none"> <li>On (top position, default) = resistance included</li> <li>Off (bottom position) = resistance excluded</li> </ul>	X	X	X	X
<b>M1</b>	Status LED of hardware functions of the secondary micro-controller: <ul style="list-style-type: none"> <li>slow flashing orange: normal behavior</li> <li>other status: contact Technical Support</li> </ul>	X	X	X	X
<b>M2</b>	Status LED of hardware functions of the primary micro-controller: <ul style="list-style-type: none"> <li>off: normal behavior</li> <li>steady red: contact Technical Support</li> </ul>	X	X	X	X
<b>N</b>	Fieldbus port no.1 with LEDs (PROFIsafe or EtherCAT® IN)	X	X	-	-
<b>O</b>	Fieldbus port no.1 with LEDs (PROFIsafe or EtherCAT® OUT)	X	X	-	-

**Note:** only for C201A-F: the processing direction is from the N connection to the O connection. In normal operation, the device receives the data from the controller on N and sends the outgoing data on O.

### 3.2.5 Type B control units

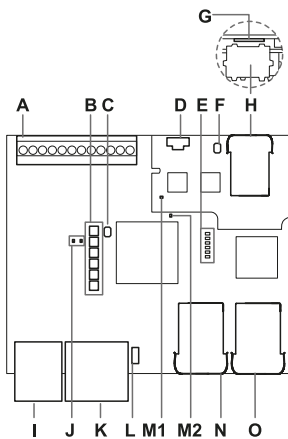

C201B-P, C201B-F

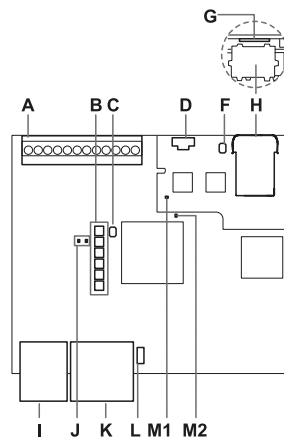

C202B

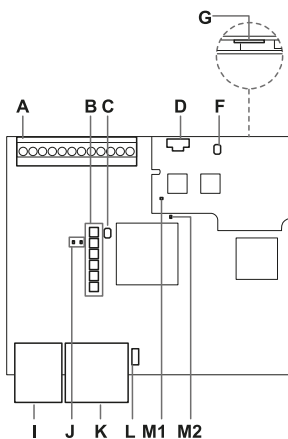

C203B

Part	Description	C201B-P	C201B-F	C202B	C203B
<b>A</b>	I/O terminal block	X	X	X	X
<b>B</b>	System status LEDs	X	X	X	X
<b>C</b>	Network parameter reset button / Factory reset button	X	X	X	X
<b>D</b>	Micro-USB port (micro-B type) for connecting the PC and communicating with the Inxpect Safety application	X	X	X	X
<b>E</b>	Fieldbus status LEDs See "PROFIsafe Fieldbus status LEDs" below or "FSoE Fieldbus status LEDs" on the next page.	X	X	-	-
<b>F</b>	SD Restore button	X	X	X	X
<b>G</b>	MicroSD slot	X	X	X	X
<b>H</b>	Ethernet port with LEDs for connecting the PC, communicating with the Inxpect Safety application, and for MODBUS communication	X	X	X	-
<b>I</b>	Power supply terminal block	X	X	X	X
<b>J</b>	Power supply LEDs (steady green)	X	X	X	X
<b>K</b>	CAN bus terminal block for connecting the first sensor	X	X	X	X
<b>L</b>	DIP switch to turn on/off the bus termination resistance: <ul style="list-style-type: none"> <li>On (top position, default) = resistance included</li> <li>Off (bottom position) = resistance excluded</li> </ul>	X	X	X	X
<b>M1</b>	Status LED of hardware functions of the secondary micro-controller: <ul style="list-style-type: none"> <li>slow flashing orange: normal behavior</li> <li>other status: contact Technical Support</li> </ul>	X	X	X	X
<b>M2</b>	Status LED of hardware functions of the primary micro-controller: <ul style="list-style-type: none"> <li>off: normal behavior</li> <li>steady red: contact Technical Support</li> </ul>	X	X	X	X
<b>N</b>	Fieldbus port no.1 with LEDs (PROFIsafe or EtherCAT® IN)	X	X	-	-
<b>O</b>	Fieldbus port no.1 with LEDs (PROFIsafe or EtherCAT® OUT)	X	X	-	-

**Note:** only for C201B-F: the processing direction is from the N connection to the O connection. In normal operation, the device receives the data from the controller on N and sends the outgoing data on O.

### 3.2.6 System status LEDs

The LEDs are each dedicated to a sensor, and can display the following statuses:

Status	Meaning
Steady green	Normal sensor function and no motion detected
Orange	Normal sensor function and some motion detected
Flashing red	Sensor in error (see "Control unit LED" on page 85)
Steady red	System error (see "Control unit LED" on page 85)
Flashing green	Sensor in boot status (see "Control unit LED" on page 85)

### 3.2.7 PROFIsafe Fieldbus status LEDs

The LEDs reflect the status of the PROFIsafe Fieldbus, and their meanings are reported below.

**Note:** F1 is the LED at the top, F6 is the LED at the bottom.

LED	Status	Meaning
F1 (power)	Steady green	Normal behavior
	Flashing green or off	Contact Technical Support

LED	Status	Meaning
F2 (boot)	Off	Normal behavior
	Steady or flashing yellow	Contact Technical Support
F3 (link)	Off	Data exchange is running with the host
	Flashing red	No data exchange
	Steady red	No physical link
F4 (not used)	-	-
F5 (diagnosis)	Off	Normal behavior
	Flashing red	DCP signal service is initiated via the bus
	Steady red	diagnostic error at PROFIsafe layer (wrong F Dest Address, watchdog timeout, wrong CRC) or diagnostic error at PROFINET layer (watchdog timeout; channel, generic or extended diagnosis present; system error)
F6 (not used)	-	-

### 3.2.8 FSoE Fieldbus status LEDs

The LEDs reflect the status of the FSoE Fieldbus as described below.

**Note:** F1 is the LED at the top, F6 is the LED at the bottom.

	LED	Status	Meaning
SYS	F1	Steady green	Normal behavior
		Flashing green or off	Contact Technical Support
	F2	Off	Normal behavior
		Steady or flashing yellow	Contact Technical Support
RUN	F3 (not used)	-	-
	F4	Off	INIT state
		Flashing green	Pre-Operational state
		Single flash green	Safe-Operational state
		Steady green	Operational state
ERR	F5	Off	Normal behavior
		Flashing red	<i>Invalid configuration:</i> General Configuration Error. Possible reason: State change commanded by the master is impossible due to register or object settings
		Single flash red	Local error: slave device application has changed the EtherCAT® state autonomously. Possible reasons: <ul style="list-style-type: none"> <li>a host watchdog timeout has occurred</li> <li>synchronization error, the device enters the Safe-Operational state automatically</li> </ul>
		Double flash red	<i>Application watchdog timeout:</i> an application watchdog timeout has occurred. Possible reason: Sync Manager watchdog timeout
	F6 (not used)	-	-

## 3.3 Control unit inputs

### 3.3.1 Introduction

The system has two type 3 dual channel digital inputs (according to IEC/EN 61131-2). Alternatively, the four channels can be used as single channel digital inputs (category 2). The ground reference is common for all the inputs (see "Technical references" on page 102).

When using digital inputs, it is mandatory that the additional SNS input "V+ (SNS)" is connected to 24 V DC and that the GND input "V- (SNS)" is connected to the ground in order to:

- perform the correct input diagnostic
- assure the system safety level

### 3.3.2 Input functions

The function of each digital input must be programmed through the Inxpect Safety application. The available functions are the following:

- **Stop signal:** additional safety-related function, which manages a specific signal to force all the safety outputs (detection signals, if present) to OFF-state.
- **Restart signal:** additional safety-related function, which manages a specific signal which enables the control unit to switch to ON-state the safety outputs related to all the detection fields with no motion detected.
- **Muting group "N":** additional safety-related function, which manages a specific signal, allowing the control unit to ignore the information from a selected sensor group.
- **Dynamic configuration switch:** additional safety-related function, which allows the control unit to select a specific dynamic configuration.
- **Fieldbus controlled** (if available): additional safety-related function monitors the input status through Fieldbus communication. For example, a generic ESPE can be connected to the input, respecting electrical specifications.
- **System recondition:** configures the system without changing any settings.
- **Restart signal + System recondition:** according to the input signal duration, performs the **Restart signal** function or the **System recondition** function.

For details about digital input signals, see "Digital input signals" on page 120.

### 3.3.3 Single or dual channel option

By default, each digital input function needs a signal on both channels to provide the redundancy required by Category 3.

The following digital input functions can also be used as a single channel (Category 2):

- **Restart signal**
- **Fieldbus controlled**
- **System recondition**
- **Restart signal + System recondition**

In the Inxpect Safety application in **Settings > Digital Input-Output**, set the digital input function to **Single channel (Category 2)** and then choose the input function for each channel.

### 3.3.4 Redundancy mode

Two types of redundancy mode are available for the dual channels input functions:

- **Coherent redundancy**

Input Channel 1	Input Channel 2	Input logic value
0	0	Low
1	1	High
0	1	Error
1	0	Error

- **Inverted redundancy**

Input Channel 1	Input Channel 2	Input logic value
0	1	Low
1	0	High
0	0	Error
1	1	Error

By default, the redundancy mode is coherent. For the following input functions, the inverted redundancy mode can be set to guarantee compatibility with different connected devices:

- **Muting group “N”** (only if pulse width = 0)
- **Restart signal**
- **Fieldbus controlled**
- **Dynamic configuration switch**
- **System recondition**
- **Restart signal + System recondition**

### 3.3.5 SNS input

The control unit is provided with an **SNS** input (high logic level (1) = 24 V) needed to check the correct functioning of the inputs.

**NOTICE:** if at least one input is connected, the SNS input "V+ (SNS)" and the GND input "V- (SNS)" must also be connected.

## 3.4 Control unit outputs

### 3.4.1 Outputs

The system has four digital OSSD short-circuit protected outputs that can be used individually (non safe) or can be programmed as dual channel safety outputs (safe) in order to ensure the system safety level.

An output is activated when it switches from OFF to ON-state and it is deactivated when it switches from ON to OFF-state.

### 3.4.2 Output functions

The function of each digital output must be programmed through the Inxpect Safety application.

The available functions are the following:

- **System diagnostic signal:** switches the selected output to OFF-state when a system fault is detected.
- **Muting enable feedback signal:** switches the selected output to ON-state in the following cases:
  - when a muting signal is received over the configured input and at least one group is in muting
  - when a muting command is received through Fieldbus communication (if available) and at least one sensor is in muting
- **Detection signal 1:** (e.g., alarm signal) switches the selected output to OFF-state when a sensor detects a motion in detection field 1, receives a stop signal from the related input, or when there is a system failure. The selected output remains in OFF-state for at least 100 ms.

**Note:** when an OSSD is configured as detection signal 1, a second OSSD is automatically assigned to it to provide a safe signal.
- **Detection signal 2:** switches the selected output to OFF-state when a sensor detects a motion in detection field 2, receives a stop signal from the related input, or when there is a system failure. The selected output remains in OFF-state for at least 100 ms.

**Note:** when an OSSD is configured as detection signal 2, a second OSSD is automatically assigned to it to provide a safe signal.
- **Detection signal 3:** switches the selected output to OFF-state when a sensor detects a motion in detection field 3, receives a stop signal from the related input, or when there is a system failure. The selected output remains in OFF-state for at least 100 ms.

**Note:** when an OSSD is configured as detection signal 3, a second OSSD is automatically assigned to it to provide a safe signal.
- **Detection signal 4:** switches the selected output to OFF-state when a sensor detects a motion in detection field 4, receives a stop signal from the related input, or when there is a system failure. The selected output remains in OFF-state for at least 100 ms.

**Note:** when an OSSD is configured as detection signal 4, a second OSSD is automatically assigned to it to provide a safe signal.

- **Fieldbus controlled** (if available): allows the specific output to be set through the Fieldbus communication.
- **Restart feedback signal:** switches the selected output to ON-state when it is possible to manually restart at least one detection field (Restart signal). It can be set as **Standard** or **Pulsed**.
  - If all the used detection fields are configured as **Automatic** restart (in **Settings > Restart function**), the selected output is always in OFF-state;
  - If at least one detection field in use is configured as **Manual** or **Safe manual** restart (in **Settings > Restart function**), the behavior depends on the option selected (see "Restart feedback signal option settings" below).
- **Static object detection feedback signal:** switches the selected output to ON-state when at least one sensor detects a static object in one of its detection fields. The selected output remains in ON-state for at least 100 ms. If, at the same time, a moving target is detected in the detection field, the **Static object detection feedback signal** will switch its selected output to OFF-state for the duration of the movement.
- **Detection signal group 1** or **Detection signal group 2:** switches the selected output to OFF-state when at least one sensor detects a motion in a detection field belonging to the group (see "Detection signal group settings" below), receives a stop signal from the related input, or when there is a system failure. The selected output remains in OFF-state for at least 100 ms.

**Note:** when an OSSD is configured as **Detection signal group 1** or **Detection signal group 2**, a second OSSD is automatically assigned to it to provide a safe signal.

Each output status can be retrieved by Fieldbus communication (if available).

### 3.4.3 Restart feedback signal option settings

If at least one detection field in use is configured as **Manual** or **Safe manual** restart (in **Settings > Restart function**), the behavior of the **Restart feedback signal** depends on the option selected:

Option	Restart feedback signal behavior
<b>Standard</b>	<ul style="list-style-type: none"> <li>• The selected output is activated (ON-state) if there is no more motion within at least one detection field configured as <b>Manual</b> or <b>Safe manual</b> restart. The ON-state lasts as long as there is an absence of motion within one or more detection fields (configured as <b>Manual</b> or <b>Safe manual</b> restart) and until the restart signal is activated on the selected input.</li> <li>• The selected output remains in OFF-state if:                             <ul style="list-style-type: none"> <li>◦ none of the detection fields (configured as <b>Manual</b> or <b>Safe manual</b> restart) are ready to be restarted, and as long as a motion (or a fault) is detected within at least one detection field (configured as <b>Manual</b> or <b>Safe manual</b> restart), or</li> <li>◦ as long as no motion is detected within any detection fields configured as <b>Manual</b> or <b>Safe manual</b> restart, but none can be restarted yet.</li> </ul> </li> </ul>
<b>Pulsed</b>	<ul style="list-style-type: none"> <li>• The selected output is activated (ON-state) if there is no more motion within at least one detection field configured as <b>Manual</b> or <b>Safe manual</b> restart. The ON-state lasts as long as there is an absence of motion within one or more detection fields (configured as <b>Manual</b> or <b>Safe manual</b> restart) and until the restart signal is activated on the selected input.</li> <li>• The selected output switches continuously between ON-state and OFF-state if none of the detection fields (configured as <b>Manual</b> or <b>Safe manual</b> restart) are ready to be restarted, and as long as a motion (or a fault) is detected within at least one detection field (configured as <b>Manual</b> or <b>Safe manual</b> restart)</li> <li>• The selected output remains in OFF-state as long as no motion is detected within any detection fields configured as <b>Manual</b> or <b>Safe manual</b> restart, but none can be restarted yet.</li> </ul>

### 3.4.4 Detection signal group settings

Each detection field of each sensor can be assigned to a group to associate them with the same safety output.

Through the Inxpect Safety application (in **Settings > Detection field groups**), each detection field of each sensor can be associated with a group or both groups. By default, a detection field does not belong to any group.



**WARNING! Consider the detection field dependency choice during the group's configuration. See "Detection fields dependency and detection signal generation" on page 40**



#### Example

It is possible to configure that the following detection fields belong to group 1:

- Detection field 1 of Sensor 1
- Detection field 1 of Sensor 3
- Detection field 2 of Sensor 1

By doing so, a specific output assigned to **Detection signal group 1** will switch to the OFF-state when a movement is detected in one of these detection fields.

### 3.4.5 Output configurations

The system installer can decide to configure the system as follows:

- two dual channel safety outputs (e.g., **Detection signal 1** and **Detection signal 2**, usually alarm and warning signals)
- one dual channel safety output (e.g., **Detection signal 1**) and two single channel output (e.g., **System diagnostic signal** and **Muting enable feedback signal**)
- each output as a single output (e.g., **System diagnostic signal**, **Muting enable feedback signal** and **Restart feedback signal**)



**WARNING!** To use Inxpect SRE 200 Series for a category 3 safety system, both the channels of a safety output must be connected to the safety system. Configuring a safety system with only one channel safety output may result in serious injuries due to an output circuit fault and a failure of the machine to stop.

### 3.4.6 Dual channel safety output configuration

The dual channel safety output is automatically obtained by the Inxpect Safety application and it only matches the single OSSD outputs as follows:

- OSSD 1 with OSSD 2
- OSSD 3 with OSSD 4

In the dual channel safety output, the output status is the following:

- activated output (24 V DC): no motion detected and normal functioning
- deactivated output (0 V DC): motion detected in the detection field or failure detected in the system

The idle signal is 24 V DC, periodically shortly pulsed to 0 V for the receiver to detect short-circuits to either 0 V or 24 V.

The pulse duration at 0 V ( $T_p$ ) can be set at 300  $\mu$ s or 2 ms through the Inxpect Safety application (**Settings** > **Digital Input-Output** > **OSSD Pulse width**).

**Note:** the devices connected to the OSSD should not respond to these temporary, self-diagnostic 0 V pulses of the signal.

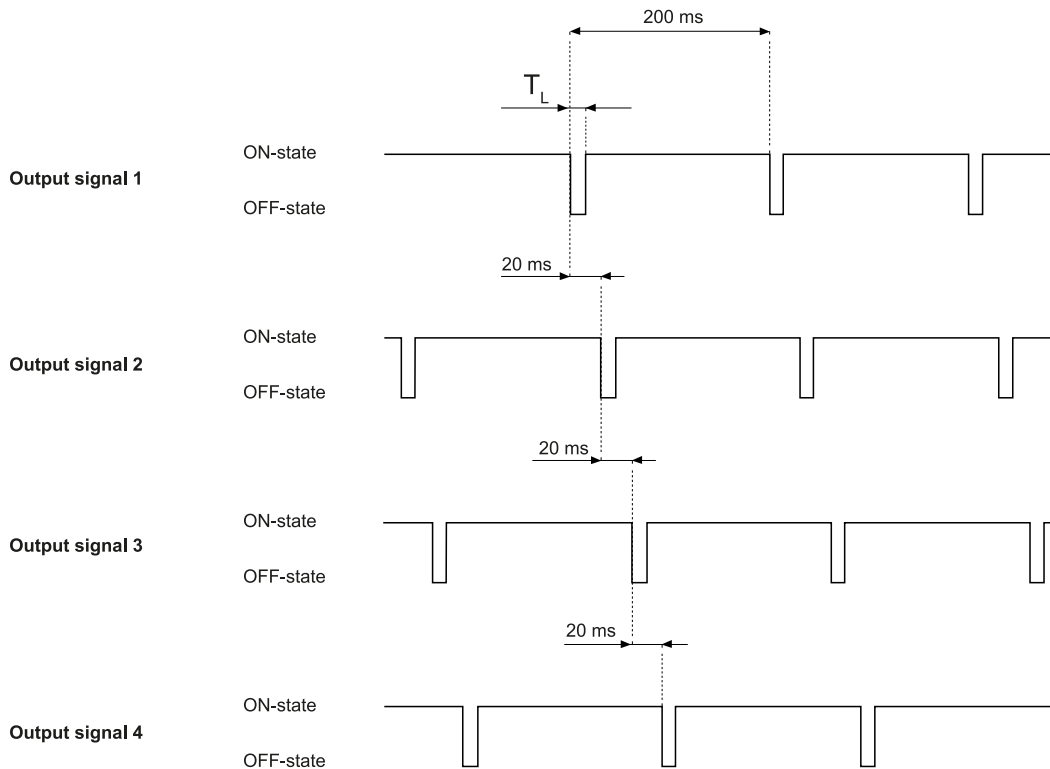

For details, see "Technical references" on page 102.

### 3.4.7 OSSD diagnostic checks

Per default, the OSSD Diagnostic check (e.g., for short-circuits) is deactivated. This check can be activated through the Inxpect Safety application (**Settings > Digital Input-Output**).

If activated, the control unit will monitor:

- short-circuit between OSSDs
- 24 V short-circuit
- open circuit (only trips on demand, i.e., when the safety function is activated on the transition from 24 V to GND)

**Note:** the short-circuit to GND (fail-safe fault) is always monitored even if the OSSD diagnostic check is deactivated.



**WARNING!** If an external common cause failure leads to a 24 V short-circuit on both the OSSDs, the control unit cannot communicate the safe state condition via OSSD. The integrator is responsible for avoiding this condition by monitoring the test pulses generated periodically on the OSSDs.

### 3.4.8 External resistor for OSSD outputs

To guarantee the correct connection between the OSSDs of the control unit and an external device, it may be necessary to add an external resistor.

If the pulse width set (**OSSD Pulse width**) is 300  $\mu$ s, it is strongly recommended to add an external resistor to guarantee the discharge time of the capacitive load. If it is set at 2 ms, an external resistance must be added if the resistor of the external load is greater than the maximum resistive load allowed (see "Technical data" on page 103).

Below are some standard values for the external resistor:

OSSD Pulse width value	External resistor ( $R_e$ )
300 $\mu$ s	1 k $\Omega$
2 ms	10 k $\Omega$

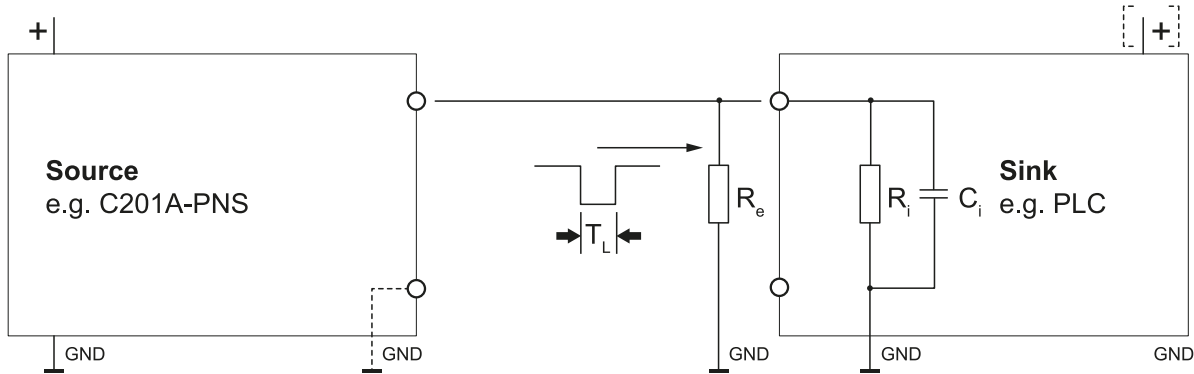

## 3.5 Sensors

### 3.5.1 9 meters range sensors

These are the main characteristics of the sensors:

**NOTICE:** the sensors connected to the control unit must all be of the same type (e.g., all 5 meters range sensors or all 9 meters range sensors).

Model	Type	Access maximum distance	Restart maximum distance	Detection speed (Access detection function)	Angular coverage (horizontal)	Angular coverage (vertical)	RCS threshold
S201A	-MLR	9 m (29.5 ft)	5 m (16.4 ft)	<ul style="list-style-type: none"> <li>Stationary use: [0.1, 1.6] m/s ([0.33, 5.25] ft/s)</li> <li>Mobile use: [0.1, 4] m/s ([0.33, 13.12] ft/s)</li> </ul>	<ul style="list-style-type: none"> <li>In the first 5 m (16.4 ft), from 10° to 100°</li> <li>From 5 to 9 m (from 16.4 to 29.5 ft), from 10° to 40°</li> </ul>	20° (Downward offset 2.5°)	RCS threshold for each sensor
S201A	-WL					20° (Downward offset 2.5°)	RCS threshold for each detection field of each sensor
S203A	-WL					12° (Downward offset 1°)	

### 3.5.2 Comparison between 3.x sensors and 5.x sensors

Based on the firmware version, the sensors can be grouped as follows:

	Model	Type	Configuration of the field of view
3.x sensors	S201A	-MLR	<ul style="list-style-type: none"> <li>detection field (from 1 to 4)</li> <li>angular coverage</li> <li>detection distance</li> </ul>
5.x sensors	S201A	-WL	<ul style="list-style-type: none"> <li>detection field (from 1 to 4)</li> <li>angular coverage</li> </ul>
	S203A	-WL	<ul style="list-style-type: none"> <li>detection distance</li> <li>classic and corridor shape, see "Advanced field of view (5.x sensors only)" on page 57.</li> </ul>

### 3.5.3 Functions

The sensors perform the following functions:

- Detect motion in their field of view.
- Send the motion detection signal to the control unit through CAN bus.
- Signal to the control unit through CAN bus the failures or faults detected on the sensor during diagnostics.

### 3.5.4 2-axes bracket

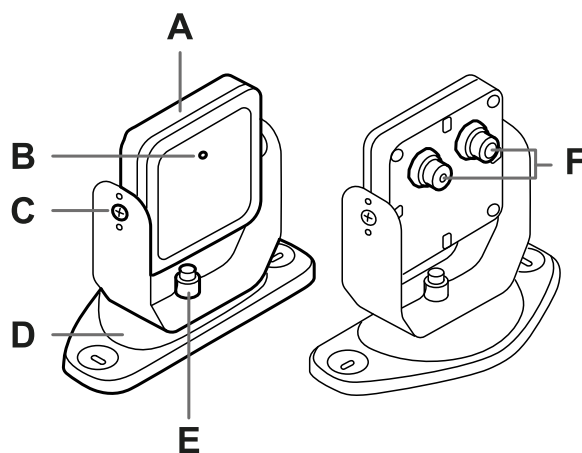

Part	Description
A	Sensor
B	Status LED
C	Tamper-proof screws to position the sensor at a specific angle around x-axis (tilt 10° steps)
D	Mounting bracket
E	Screw to position the sensor at a specific angle around y-axis (pan 10° steps)
F	Connectors for connecting the sensors in a chain and to the control unit

### 3.5.5 3-axes bracket

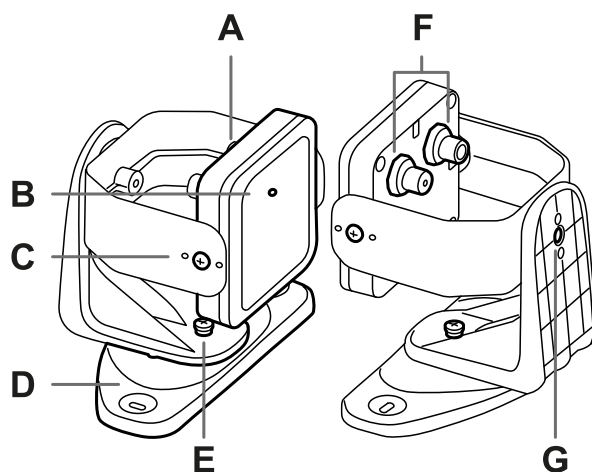

Part	Description
A	Sensor
B	Status LED
C	Tamper-proof screws to position the sensor at a specific angle around x-axis (tilt 10° steps)
D	Mounting bracket
E	Tamper-proof screw to position the sensor at a specific angle around y-axis (pan 10° steps)
F	Connectors for connecting the sensors in a chain and to the control unit
G	Tamper-proof screw to position the sensor at a specific angle around z-axis (roll 10° steps)

### 3.5.6 Status LED

Status	Meaning
Steady blue	Sensor is working. No motion detected.
Flashing blue	Sensor is detecting motion. Not available if the sensor is in muting.
Purple	Firmware update conditions (see "Sensor LED" on page 87)
Red	Error conditions (see "Sensor LED" on page 87)

## 3.6 Inxpect Safety application

### 3.6.1 Functions

The application permits the following main functions to be performed:

- Configure the system.
- Create the configuration report.
- Check system functioning.
- Download system log.

### 3.6.2 Inxpect Safety application usage

To use the application, the control unit must be connected to a computer with a data USB cable or, if the Ethernet port is available, an Ethernet cable. The USB cable allows to configure the system locally, whereas the Ethernet cable allows to do it remotely.

The Ethernet communication between the control unit and the Inxpect Safety application is secured by the most advanced security protocols (TLS).

### 3.6.3 Authentication

The application can be downloaded free of charge at <https://tools.inxpect.com>.

Different user levels are available. The admin user is in charge of user management. All the passwords can be set through the application and then saved on the control unit.



### 3.6.4 User levels

These are the functions available for each user level:

	Observer	Expert	Engineer	Admin	Service*
Read system configuration	x	x	x	x	x
Validation	-	x	x	x	x
Download log files	-	x	x	x	x
Sensor setup (e.g., Node ID) and configuration	-	-	x	x	-
Digital I/O configuration	-	-	x	x	-
Backup / Restore configuration	-	-	x	x	-
Network and Fieldbus settings (Network and MODBUS parameters, PROFIsafe F-addresses and endianness, FSoE Safe Address), and System labels	-	-	-	x	-
Control unit firmware upgrade	-	-	-	x	-
User management	-	-	-	x	-
SD Backup and SD Restore (if available)	-	-	-	x	-
Technical support and maintenance	-	-	-	-	x
Debug and statistical information	-	-	-	-	x

**Note\***: Service user can be enabled/disabled by the administrator. Since only Inxpect technicians are allowed to access as Service, the Service user is protected by an activation code.

### 3.6.5 Main menu

Page	Function
<b>Dashboard</b>	<p>Display main information on the configured system.</p> <p><b>Note:</b> the messages show the same information in the log files. For the meanings of the messages, see the chapters on logs in "Troubleshooting" on page 85.</p>
<b>Configuration</b>	<p>Define the monitored area.</p> <p>Configure the sensors, their shape (for 5.x sensors), and the detection fields.</p> <p>Define the dynamic configurations.</p> <p>Choose the safety working mode.</p> <p>Enable the static object detection option.</p> <p>Set the restart timeout.</p> <p>Enable the Custom target detection</p> <p>Set the RCS Threshold parameter</p>
<b>Settings</b>	<p>Configure the sensor groups.</p> <p>Choose the detection fields dependency.</p> <p>Enable the anti-tampering functions.</p> <p>Synchronize more control units.</p> <p>Configure the inputs and outputs function.</p> <p>Perform the configuration backup and load a configuration.</p> <p>Download the log.</p> <p>Perform the sensor Node ID assignment.</p> <p>Other general functions.</p>
<b>Admin</b>	<p>Configure and manage the users.</p> <p>Enable the SD Backup and the SD Restore.</p> <p>Perform a factory reset.</p> <p>Configure, show, and change the Network parameters (if available).</p> <p>Configure, show and change the MODBUS parameters (if available).</p> <p>Configure, show and change the Fieldbus parameters (if available).</p> <p>Set labels for control units and sensors.</p>
<b>Validation</b>	<p>Start the validation procedure.</p> <p><b>Note:</b> the messages shown are those in the log file. To know the meaning of the messages, see the chapters on logs in "Troubleshooting" on page 85.</p>
 <b>REFRESH CONFIGURATION</b>	<p>Refresh configuration or ignore unsaved changes.</p>
<b>User</b>	<p>Change user profile.</p> <p>Modify account settings.</p>
<b>Control unit</b>	<p>Retrieve control unit information.</p> <p>Close the connection with the control unit and allow it to connect to another control unit.</p>
	<p>Change the language.</p>

## 3.7 Fieldbus communication (PROFIsafe)

### 3.7.1 PROFIsafe support

The safety communication using PROFIsafe is available on all the control units provided with the PROFIsafe interface. For details, see "Control units" on page 17.

### 3.7.2 Communication with the machinery

The Fieldbus makes the following actions possible:

- Choose from 1 to 32 preset configurations dynamically.
- Read the status of the inputs.
- Control the outputs.
- Read the target data.
- Mute the sensors.
- Enable the restart signal.
- Enable the system recondition signal.

For details, see the PROFIsafe communication Reference guide.

### 3.7.3 Input data coming from the PLC

If neither digital input nor OSSD is configured as **Fieldbus controlled**, the behavior of the input data coming from the PLC is as described below:

Condition	Input data coming from the PLC	System behavior
IOPS (PLC provider status) = bad	the last valid value of the input variable is retained	the system keeps working in its normal operating state
Connection loss	the last valid value of the input variable is retained	the system keeps working in its normal operating state
After power-up	the initial values (set to 0) are used for the input variables	the system keeps working in its normal operating state

If at least one digital input or OSSD is configured as **Fieldbus controlled**, the behavior of the input data coming from the PLC is as described below:

Condition	Input data coming from the PLC	System behavior
IOPS (PLC provider status) = bad	the last valid value of the input variable is retained	the system keeps working in its normal operating state
Connection loss	the last valid value of the input variable is retained	the system transits to safe state, deactivating the OSSDs, until the connection is re-established.
After power-up	the initial values (set to 0) are used for the input variables	the system remains in a safe state with the OSSDs deactivated, until the input data are passivated.

### 3.7.4 Data exchanged through PROFIsafe

The following table details the data exchanged through the Fieldbus communication:



**WARNING! The system is in the safe state if the control unit status byte of the System configuration and status module PS2v6 or PS2v4 is different from "0xFF".**

Data type	Description	Communication direction
Safe	<p>SYSTEM STATUS DATA</p> <p>Control unit:</p> <ul style="list-style-type: none"> <li>internal status</li> <li>status of each of the four OSSDs</li> <li>status of each single channel and dual channel input</li> </ul> <p>Sensor:</p> <ul style="list-style-type: none"> <li>status of each detection field (target detected or not) or error status</li> <li>status of static object detection option</li> <li>muting status</li> </ul>	from the control unit
Safe	<p>SYSTEM SETTING COMMAND</p> <p>Control unit:</p> <ul style="list-style-type: none"> <li>set the ID of the dynamic configuration that shall be activated</li> <li>set the status of each of the four OSSDs</li> <li>save the reference for the anti-rotation around axes</li> <li>enable the restart signal</li> <li>enable the system recondition signal</li> </ul> <p>Sensor:</p> <ul style="list-style-type: none"> <li>set the muting status</li> </ul>	to the control unit
Safe	<p>DYNAMIC CONFIGURATION STATUS</p> <ul style="list-style-type: none"> <li>ID of the dynamic configuration currently active</li> <li>signature (CRC32) of the dynamic configuration ID currently active</li> </ul>	from the control unit
Safe	<p>TARGET DATA</p> <ul style="list-style-type: none"> <li>Current distance and angle of the targets detected by each sensor. For each detection field of each sensor, only the closest target to the sensor is considered.</li> </ul>	from the control unit
Unsafe	<p>DIAGNOSTIC DATA</p> <p>Control unit:</p> <ul style="list-style-type: none"> <li>internal status with an extended description of the error condition</li> </ul> <p>Sensor:</p> <ul style="list-style-type: none"> <li>internal status with an extended description of the error condition</li> </ul>	from the control unit
Unsafe	SYSTEM STATUS AND TARGET DATA	from the control unit

## 3.8 Fieldbus communication (Safety over EtherCAT® - FSoE)

### 3.8.1 FSoE support

The safety communication using FSoE is available on all the control units provided with the FSoE interface. For details, see "Control units" on page 17.

### 3.8.2 Communication with the machinery

The Fieldbus makes the following actions possible:

- Choose dynamically from 1 to 32 preset configurations.
- Read the status of the inputs.
- Control the outputs.
- Mute the sensors.
- Enable the restart signal.
- Enable the system recondition signal.

For details, see the FSoE communication Reference guide.



### 3.8.3 Data exchanged through FSoE

The following table details the data exchanged through the Fieldbus communication:



**WARNING! The system is in the safe state if Byte 0 of the selected TxPDO has at least one of its bits equal to 0, except for bit 4, which can assume any value.**

Data type	Description	Communication direction
Safe	SYSTEM STATUS DATA Control unit: <ul style="list-style-type: none"> <li>internal status</li> <li>status of each of the four OSSDs</li> <li>status of each of single channel inputs and dual channel inputs</li> </ul> Sensor: <ul style="list-style-type: none"> <li>status of each detection field (target detected or not) or error status</li> <li>status of Static object detection for each detection field</li> <li>muting status</li> </ul>	from the control unit
Safe	SYSTEM SETTING COMMAND Control unit: <ul style="list-style-type: none"> <li>set the ID of the dynamic configuration that shall be activated</li> <li>set the status of each of the four OSSDs</li> <li>enable the system recondition signal</li> <li>enable the restart signal</li> </ul> Sensor: <ul style="list-style-type: none"> <li>set the muting status</li> </ul>	to the control unit
Safe	DYNAMIC CONFIGURATION STATUS <ul style="list-style-type: none"> <li>ID of the dynamic configuration currently active</li> <li>signature (CRC32) of the dynamic configuration ID currently active</li> </ul>	from the control unit
Unsafe	DIAGNOSTIC DATA Control unit: <ul style="list-style-type: none"> <li>internal status with an extended description of the error condition</li> </ul> Sensor: <ul style="list-style-type: none"> <li>internal status with an extended description of the error condition</li> </ul>	from the control unit
Unsafe	SYSTEM STATUS	from the control unit

## 3.9 MODBUS communication

### 3.9.1 MODBUS support

The safety communication using MODBUS is available on all the control units provided with the MODBUS interface. For details, see "Control units" on page 17.

### 3.9.2 MODBUS communication enabling

In the Inxpect Safety application, click on **Admin > MODBUS Parameters** and check that the feature is enabled (**ON**).

Within the Ethernet network, the control unit acts like a server. The client must send requests to the IP address of the server on the MODBUS listening port (default port is 502).

To show and change the address and the port, click on **Admin > Network Parameters** and **Admin > MODBUS Parameters**.

### 3.9.3 Data exchanged through MODBUS

The following table details the data exchanged through the MODBUS communication:

Data type	Description	Communication direction
Unsafe	SYSTEM STATUS DATA Control unit: <ul style="list-style-type: none"> <li>internal status</li> <li>status of each of the four OSSDs</li> <li>status of each single channel and dual channel input</li> <li>revision information</li> </ul> Sensor: <ul style="list-style-type: none"> <li>status of each detection field (target detected or not) or error status</li> <li>muting status</li> <li>revision information</li> </ul>	from the control unit
Unsafe	DYNAMIC CONFIGURATION STATUS <ul style="list-style-type: none"> <li>ID of the dynamic configuration currently active</li> <li>signature (CRC32) of the dynamic configuration ID currently active</li> </ul>	from the control unit
Unsafe	TARGET DATA <ul style="list-style-type: none"> <li>Current distance and angle of the targets detected by each sensor. For each detection field of each sensor, only the closest target to the sensor is considered.</li> </ul>	from the control unit
Unsafe	DIAGNOSTIC DATA Control unit: <ul style="list-style-type: none"> <li>internal status with an extended description of the error condition</li> </ul> Sensor: <ul style="list-style-type: none"> <li>internal status with an extended description of the error condition</li> </ul>	from the control unit

## 3.10 System configuration

### 3.10.1 System configuration

The control unit parameters have their own default values that can be modified via the Inxpect Safety application (see "Configuration application parameters" on page 115).

When a new configuration is saved, the system generates the configuration report.

**Note:** after a physical change of the system (e.g., new sensor installed), the system configuration must be updated and a new configuration report must be generated, too.

### 3.10.2 Dynamic system configuration

Inxpect SRE 200 Series allows a real-time adjustment of the most important system parameters, providing the means to switch dynamically among different preset configurations. Via the Inxpect Safety application, once the first system configuration (default configuration) has been set, it is possible to set alternative presets to allow a dynamic real-time reconfiguration of the monitored area. The alternative presets are 7 through digital input and 31 through Fieldbus (if available).

### 3.10.3 Dynamic system configuration parameters

These are the programmable parameters for each sensor:

- detection field (from 1 to 4)
- for 3.x sensors, RCS Threshold for each sensor
- for 5.x sensors, RCS Threshold for each detection field of each sensor

These are the programmable parameters for each detection field:

- angular coverage
- detection distance
- safety working mode (**Access detection and restart prevention** or **Always-on access detection**) (see "Safety working modes and safety functions" on page 42)
- only for 5.x sensors: classic and corridor shapes (see "Advanced field of view (5.x sensors only)" on page 57)
- static object detection option (see "Restart prevention function: static object detection option" on page 45)
- restart timeout

All the remaining system parameters cannot be changed dynamically and are considered static.

### 3.10.4 Dynamic system configuration switch

One of the preset configurations can be activated dynamically either through the digital inputs (**Dynamic configuration switch**) or through the safety Fieldbus (if available).



**WARNING!** If one or more digital inputs are configured as "Dynamic configuration switch", a switch through the safety Fieldbus is not considered.

**Note:** if the application type is set as **Stationary**, the system can manage only one dynamic configuration.

### 3.10.5 Dynamic configuration through the digital inputs

To activate one of the preset configurations dynamically, one or both the digital inputs of the control unit can be used. The result is the following:

If...	Then it is possible to switch dynamically between...
only <b>one</b> digital input is configured as <b>Dynamic configuration switch</b>	<b>two</b> preset configurations (see "Case 1" below and "Case 2" below)
<b>both</b> digital inputs are configured as <b>Dynamic configuration switch</b> and the encoded channel option is disabled	<b>four</b> preset configurations (see "Case 3" on the next page)
<b>both</b> digital inputs are configured as <b>Dynamic configuration switch</b> and the encoded channel option is enabled	<b>eight</b> preset configurations (see "Case 4" on the next page)

**Note:** the configuration change is safe because two-channel inputs are used.

**Note:** if the encoded channel option is enabled, any invalid combination that lasts more than 33 ms results in a fault on the inputs that brings the system to a safe state.

#### Case 1

The first digital input has been configured as **Dynamic configuration switch**.

Dynamic configuration number	Input 1 (CH1 and CH2)	Input 2
#1	<b>0</b>	-
#2	<b>1</b>	-

0 = signal deactivated; 1 = signal activated

#### Case 2

The second digital input has been configured as **Dynamic configuration switch**.

Dynamic configuration number	Input 1	Input 2 (CH1 and CH2)
#1	-	<b>0</b>
#2	-	<b>1</b>

0 = signal deactivated; 1 = signal activated

## Case 3

Both digital inputs have been configured as **Dynamic configuration switch**, and the encoded channel option is disabled.

Dynamic configuration number	Input 1 (CH1 and CH2)	Input 2 (CH1 and CH2)
#1	0	0
#2	1	0
#3	0	1
#4	1	1

0 = signal deactivated; 1 = signal activated

## Case 4

Both digital inputs have been configured as **Dynamic configuration switch**, and the encoded channel option is enabled.

The valid combinations are only those that differ at least by two values, and they are listed below:

Dynamic configuration number	Input 1		Input 2	
	CH1	CH2	CH1	CH2
#1	1	0	0	0
#2	0	1	0	0
#3	0	0	1	0
#4	0	0	0	1
#5	0	1	1	1
#6	1	0	1	1
#7	1	1	0	1
#8	1	1	1	0

0 = signal deactivated; 1 = signal activated

### 3.10.6 Dynamic configuration through the safety Fieldbus

To activate one of the preset configurations dynamically, connect an external safety PLC that communicates through the safety Fieldbus to the control unit. This makes it possible to dynamically switch between all the preset configurations, therefore up to 32 different configurations. For all the parameters used for each configuration, see "Dynamic system configuration" on page 34.

For details about the supported protocol, please refer to the Fieldbus manual.



**WARNING! Before activating one of the preset configurations through the safety Fieldbus, ensure that none of the digital inputs is configured as Dynamic configuration switch; otherwise, the Inxpect SRE 200 Series ignores all the switches made through the safety Fieldbus.**

# 4. Functioning principles

---

## Contents

This section includes the following topics:

<b>4.1 Sensor functioning principles</b> .....	<b>37</b>
<b>4.2 Detection fields</b> .....	<b>37</b>

## 4.1 Sensor functioning principles

---

### 4.1.1 Introduction

The sensor is an FMCW (Frequency Modulated Continuous Wave) radar device based on a proprietary detection algorithm. It is also a multi-target sensor that sends pulses and receives information, analyzing the reflection of the nearest moving target that it encounters within each detection field.

The sensor can detect the current distance and the angle of each target.

Each sensor has its own fieldset. The fieldset corresponds to the structure of the field of view, which is composed of detection fields (see "Detection fields" below).

### 4.1.2 Factors that influence the sensor field of view and object detection



**WARNING! The presence of conductive material on the sensor could affect its field of view and, thus, object detection. For proper and safe system operation, validate the system under this condition.**

### 4.1.3 Factors that influence the reflected signal

The signal reflected by the object depends on several characteristics of the same object:

- Metallic objects have a very high reflection coefficient, while paper and plastic reflect only a small portion of the signal
- The greater the surface exposed to the radar, the greater the reflected signal
- All other factors being equal, objects positioned directly in front of the radar generate a more significant signal than objects to the side
- Motion speed
- Inclination

All these factors have been analyzed for a human body during the safety validation of Inxpect SRE 200 Series and cannot lead to a dangerous situation. These factors may occasionally influence the behavior of the system causing spurious activation of the safety function.

### 4.1.4 Detected and missed objects

The signal analysis algorithm considers only those objects that move within the field of view, ignoring completely static objects (if the static object detection option is disabled).

Furthermore, a *falling objects* algorithm allows ignoring undesired alarms generated by small work waste products that fall in the first part of the sensor's field of view.

### 4.1.5 Interference with pacemakers or other medical devices

Radiation from Inxpect SRE 200 Series does not interfere with pacemakers or other medical devices.

## 4.2 Detection fields

---

### 4.2.1 Introduction

The field of view of each sensor can be composed of up to four detection fields. Each of the four detection fields has a dedicated detection signal.

 **WARNING! Configure the detection fields and associate them with the dual channel safety outputs according to the risk assessment requirements.**

### 4.2.2 Detection field parameters

These are the programmable parameters for each detection field:

- angular coverage
- detection distance
- safety working mode (**Access detection and restart prevention** or **Always-on access detection**) (see "Safety working modes and safety functions" on page 42)
- restart timeout
- static object detection option
- only for 5.x sensors, Advanced field of view shape
- RCS Threshold

### 4.2.3 Angular coverage

The angular coverage has the following values:

- in a range from 10° to 100° in the first 5 m (16.4 ft) of the field of view
- in a range from 10° to 40° from 5 to 9 m (from 16.4 to 29.5 ft) of the field of view

The angular coverage of the detection field must be wider than, or equal to, the angular coverage of the following detection fields.

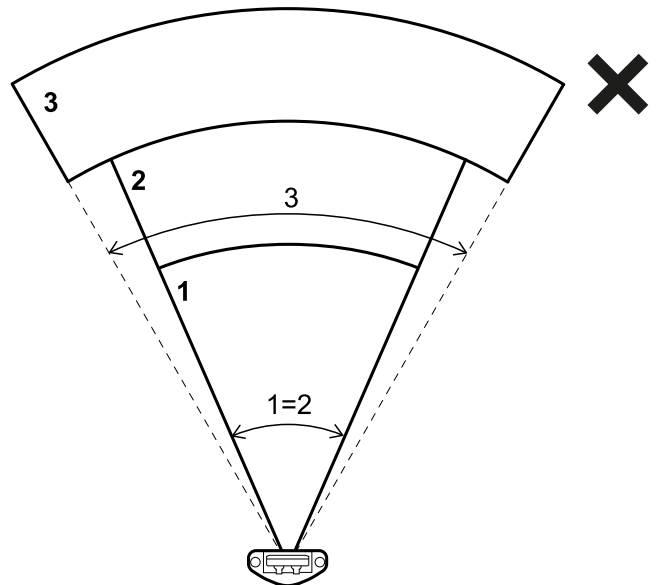
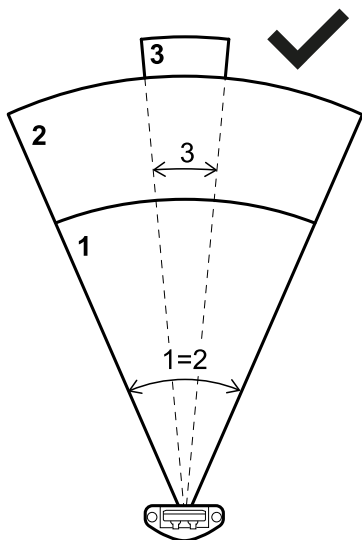

### 4.2.4 Detection distance

The detection distance of the first detection field starts from the sensor. The detection distance of one field starts where the one of the previous field ends.

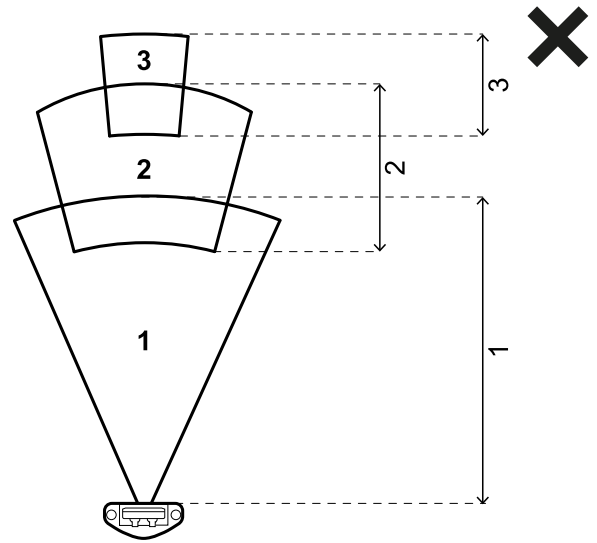
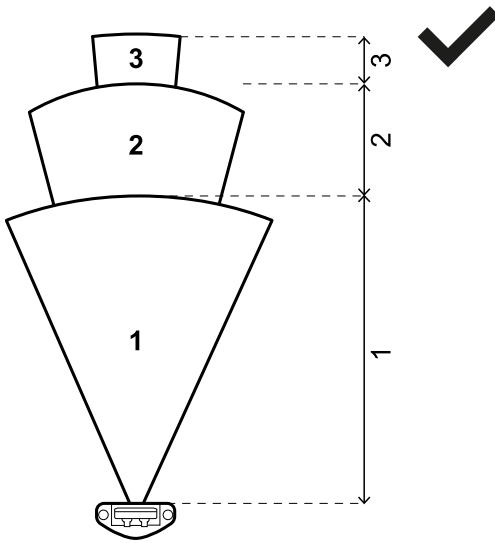

The detection distance of one or more fields can be 0 (e.g., detection field 3). The first detection field with a detection distance other than 0 (e.g., detection field 1) must have a minimum detection distance of 500 mm (for 3.x sensors) or 200 mm (for 5.x sensors).

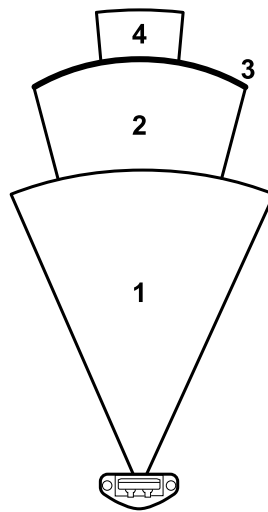

### 4.2.5 Detection fields dependency and detection signal generation

If a sensor detects motion within a detection field, its detection signal changes status and, when configured, the related safety output is deactivated. The behavior of the outputs related to the following detection fields depends on the detection field dependency set:

If...	Then...
the <b>Dependent mode</b> is set and thus detection fields are dependent on each other	if a sensor detects motion within a detection field, all the outputs related to its following detection fields are deactivated too.  <div style="border: 1px solid #ccc; padding: 5px; background-color: #f9f9f9;">                         Example                          Detection field configured: 1, 2, 3                          Detection field with target detected: 2                          Detection field in alarm status: 2, 3                     </div>
the <b>Independent mode</b> is set and thus detection fields are independent from each other	if a sensor detects motion within a detection field, only the output related to that detection field is deactivated.  <div style="border: 1px solid #ccc; padding: 5px; background-color: #f9f9f9;">                         Example                          Detection field configured: 1, 2, 3                          Detection field with target detected: 2                          Detection field in alarm status: 2                     </div>

 **WARNING!** If detection fields are independent, an evaluation of the safety of the monitored area must be performed during the risk assessment. The blind area generated by a target can prevent the sensor from detecting targets in the following detection fields.

In this example, both detection field 1 and 2 generate a detection signal, for target **[A]** and **[B]** respectively.

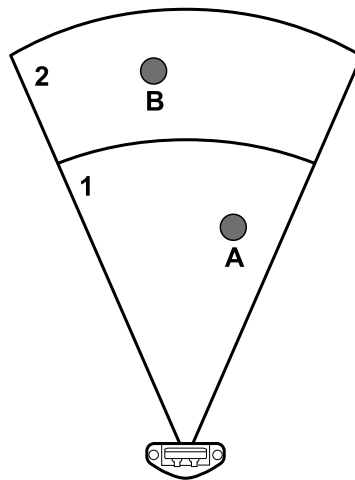



In this example, detection field 1 generates a detection signal for target **[A]** but target **[B]** could not be detected.

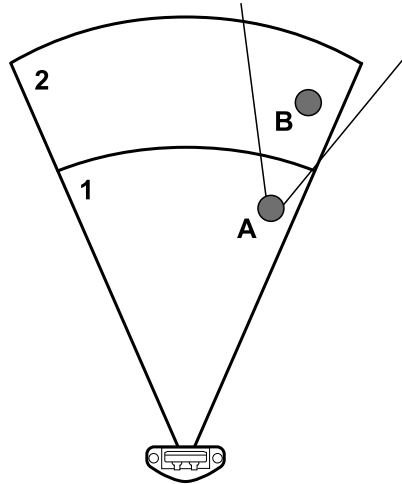

In the **Inxpect Safety** application, click on **Settings** > **Advanced** > Detection field dependency to set the dependency mode of the detection fields.

#### 4.2.6 Independent detection fields: a use case

It can be useful to set the detection fields as independent, for example, if there is a scheduled temporary motion of an object in a detection field. An example can be a robotic arm moving from right to left within the detection field 1 only during a specific phase of the operative cycle.

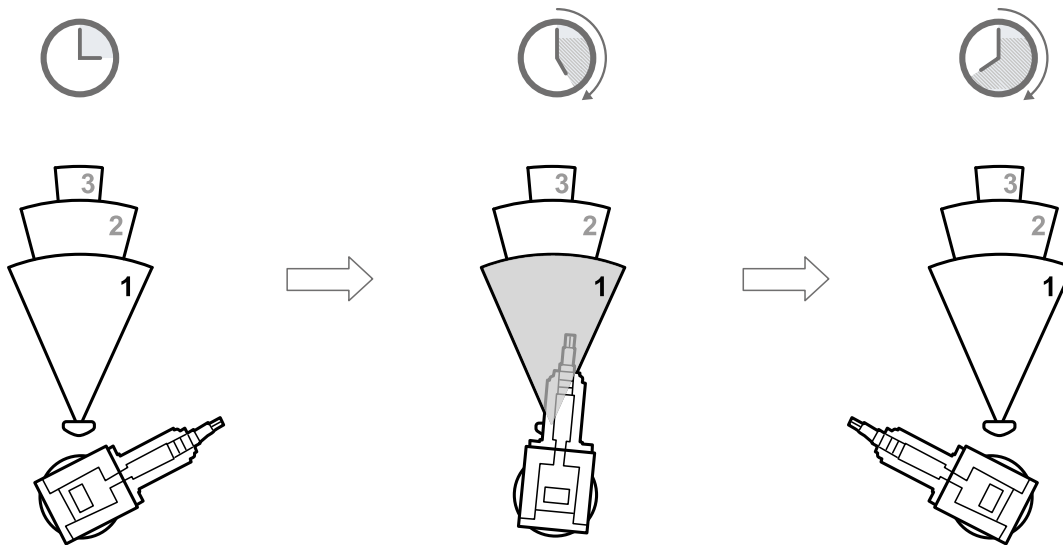

In this case, it is possible to ignore the detection signal in the detection field 1, thus avoiding unnecessary downtime.

**WARNING!** Evaluate the safety of the monitored area during risk assessment before deciding to ignore the detection signal of the detection field 1.

**WARNING!** The blind area generated by the moving robotic arm can prevent the sensor from detecting targets in the following other detection fields for a time interval. This time must be considered when defining the detection distance for detection field 2.

# 5. Safety functions

## Contents

This section includes the following topics:

5.1 Safety working modes and safety functions .....	42
5.2 Safety working mode: Access detection and restart prevention (default) .....	43
5.3 Safety working mode: Always-on access detection .....	44
5.4 Custom target detection .....	44
5.5 Restart prevention function: static object detection option .....	45
5.6 Features of the restart prevention function .....	46

## 5.1 Safety working modes and safety functions

### 5.1.1 Introduction

Each detection field of each sensor can perform the following safety working modes:

- **Access detection and restart prevention**
- **Always-on access detection**

Each safety working mode is composed of one or both of the following safety functions:

Function	Description
Access detection	<ul style="list-style-type: none"> <li>• Human detection: the machinery is reverted into a safe status when one or more persons enter the dangerous area</li> <li>• Custom target detection (see "Custom target detection" on page 44): the machinery is reverted into a safe status when one or more objects with an RCS higher than a set threshold enter the dangerous area</li> </ul> <p> <b>WARNING! These safety-related functions work in exclusive mode: with the activation of the Custom target detection, the detection of a human body is no longer guaranteed.</b></p>
Restart prevention	The machinery is prevented from restarting if people are in the dangerous area.

### 5.1.2 Safety working modes

Via the Inxpect Safety application, you can select which safety working mode each sensor will employ for each of its detection fields:

- **Access detection and restart prevention (default):**
  - The sensor performs the access detection function when it is in normal operation (**No alarm** status).
  - The sensor performs the restart prevention function when it is in alarm status (**Alarm** status).
- **Always-on access detection:**
  - The sensor always performs the access detection function (**No alarm** status + **Alarm** status).

### 5.1.3 Access detection speed limits

The speed limits of the movements detected by the access detection function are reported below:

Application type	Minimum speed	Maximum speed
<b>Stationary</b>	0.1 m/s (0.33 ft/s)	1.6 m/s (5.25 ft/s)
<b>Mobile</b>	0.1 m/s (0.33 ft/s)	4 m/s (13.12 ft/s)

## 5.2 Safety working mode: Access detection and restart prevention (default)

### 5.2.1 Introduction

This safety working mode is composed of the following safety functions:

- access detection (Human detection or Custom target detection)
- restart prevention

### 5.2.2 Safety function: access detection (Human detection or Custom target detection)

Access detection allows what follows:

When...	Then...
no motion is detected in the detection field	the safety outputs remain active
motion is detected in the detection field (see "Access detection speed limits" on the previous page)	<ul style="list-style-type: none"> <li>• the safety outputs are deactivated</li> <li>• the restart prevention function is activated</li> </ul>

### 5.2.3 Safety function: restart prevention

**Note:** the maximum distance for the restart prevention function is 5 m (16.4 ft).

The restart prevention function remains active and the safety outputs deactivated as long as motion is detected in the detection field, or, with the static object detection option enabled (see "Restart prevention function: static object detection option" on page 45), as long as a static object is detected in the detection field.

The sensor can detect micro-movements of just a few millimeters, such as breathing movements (with normal breathing or a short apnea) or the movements necessary for a person to remain in balance in an upright or squatting position.

The system sensitivity is higher than the sensitivity that characterizes the access detection function. For this reason, the system reaction to vibrating and moving parts is different.

The sensor guarantees the detection of people moving at any speed from 0 up to 1.6 m/s (5.25 ft/s)\*, provided that the guidelines described in "Sensor positioning guidelines" on page 46 are fulfilled.

**Note\*:** a stationary person still has static residual movements that the radar can detect.

 **WARNING! When the restart prevention function is active the monitored area may be affected by the position and inclination of the sensors, as well as by their installation height and angular coverage (see "Sensor position" on page 53).**

### 5.2.4 Restart timeout parameter

When the system does not detect motion anymore or, with static object detection option enabled, no static object is detected, the OSSD outputs remain in OFF-state for the time set in the **Restart timeout** parameter.

The default and minimum certified value is 4 s (Certified Restart Timeout, CRT) while the maximum value is 60 s.

 **WARNING! The static object detection option allows reducing the value of the Restart timeout parameter and therefore it might affect the reliability of the restart prevention function (see "Restart timeout parameter" on page 45).**

## 5.3 Safety working mode: Always-on access detection

### 5.3.1 Safety function: access detection (Human detection or Custom target detection)

This is the only safety function available for the **Always-on access detection**. Access detection allows what follows:

When...	Then...
no motion is detected in the detection field	the safety outputs remain active
motion is detected in the detection field	<ul style="list-style-type: none"> <li>the access detection function remains active</li> <li>the safety outputs are deactivated</li> <li>the sensitivity remains as it was before the motion detection</li> </ul>



**WARNING!** If the **Always-on access detection** is selected, additional safety measures must be introduced to ensure the restart prevention function.

### 5.3.2 T<sub>OFF</sub> parameter

If the safety working mode is **Always-on access detection**, when the system does not detect motion anymore, the OSSD outputs remain in OFF-state for the time set in the **T<sub>OFF</sub>** parameter.

The T<sub>OFF</sub> value can be set from 0.1 s to 60 s.

## 5.4 Custom target detection

### 5.4.1 Introduction

The Custom target detection is a safety function that allows detecting the access of one or more objects with an RCS higher than a specific value.

*Note: the Custom target detection is referred only to the access detection safety function. If the Custom target detection is enabled, it does not affect the detection capabilities of the restart prevention function or the static object detection option.*

### 5.4.2 How to enable the Custom target detection

The Custom target detection can be enabled on each sensor individually by setting its RCS threshold to a value higher than 0 dB.

### 5.4.3 RCS threshold description

The RCS threshold is expressed in decibels, and it represents the RCS value above which the system guarantees 100% detection.

*Note: the reference (0 dB) corresponds to 0.17 m<sup>2</sup>, which is the RCS of a detectable human body (Human detection).*

In the **Configuration** page of the Inxpect Safety application you can set the **RCS Threshold** parameter for each sensor.

### 5.4.4 RCS threshold range

The minimum and the default value is 0 dB (Human detection). The maximum value is 70 dB.

For example, with the RCS threshold set to 20 dB, the system guarantees 100% detection of targets with RCS greater than 20 dB (Custom target detection).

*Note: setting the **RCS Threshold** to a value different from 0 dB does not guarantee that targets with RCS lower than the threshold will be filtered out and therefore not detected.*

*Note: an object with an **RCS Threshold** lower than the chosen threshold could not be detected but it could create an occlusion inside the sensor field of view.*

### 5.4.5 RCS Reader Tool

The system provides the RCS Reader Tool application to assist in setting the parameter. You can access this tool from the **Configuration** page of the Inxpect Safety application.

For information on how to use the RCS Reader Tool, refer to RCS Reader Tool instructions, downloadable from the site <https://tools.inxpect.com>.

### 5.4.6 When to enable the Custom target detection

In outdoor installations on moving elements, you may need to increase the RCS Threshold, for example, under these conditions:

- to reduce weather disturbances or any other disturbances
- to detect only collisions with large objects or other vehicles.



**WARNING! This setting no longer guarantees that the system will detect human access. Take all necessary precautions to prevent people from entering the area.**

## 5.5 Restart prevention function: static object detection option

### 5.5.1 Introduction

The static object detection option allows the restart prevention function also to detect static objects in the dangerous area.

*Note: the static object detection is an option of the restart prevention function and therefore cannot be enabled beyond 5 m (16.4 ft).*

**NOTICE:** the ability to detect an object depends on the RCS of the object. The static object detection option does not guarantee 100% detection of static objects.

### 5.5.2 Availability

The static object detection option is available for:

- control unit firmware version 1.5.0 or later, and
- sensor firmware version 3.0 or later.

### 5.5.3 Possible applications

This option can be useful if the sensor is installed on moving elements (see "Installations on moving elements (Mobile application)" on page 63) or to prevent the restart of a robot that could bump into a static object in the area temporarily.

### 5.5.4 Operation

The option can be enabled for each detection field of each sensor with the safety working mode set to **Access detection and restart prevention**. Enable the option only if the detection field is free of static objects; otherwise, the system would never reactivate the detection signals after a motion is detected in the area.

### 5.5.5 Settings

It is possible to increase or decrease the sensitivity of the static object detection of the sensors through the Inxpect Safety application (**Settings > Advanced > Static object detection sensitivity**)

### 5.5.6 Restart timeout parameter

With the static object detection option enabled, the **Restart timeout** parameter's minimum value is 0.1 s.



**WARNING! If the Restart timeout is set to a value less than 4 s, the sensor is no longer able to detect breathing movement or the movements necessary for a person to remain in balance in an upright or a squatting position. Set a value less than 4 s only for areas where people have no access.**

## 5.6 Features of the restart prevention function

### 5.6.1 Sensor positioning guidelines

The restart prevention function is effective if the sensor can detect a person's movements or their static residual movements. To detect people who are not standing or squatting, it is important that the sensor can clearly detect the person's chest.

Particular attention should be paid to the following situations:

- There are objects that limit or prevent the sensor from detecting motion.
- The risk assessment requires the detection of a lying person and the sensor is installed at a height below 2.5 m (8.2 ft) or with an inclination lower than 60° downward.
- The sensor does not detect a sufficient portion of the body or does not properly detect the person's chest.

A validation procedure (see "Validate the safety functions" on page 78) must be performed when one or more of the above conditions are met.

If the conditions described above limit the performance of the sensor, take the following steps to reach an appropriate level of performance:

- Increase the **Restart timeout** parameter.
- Change the position of the sensors.
- Add more sensors.

If one or more of the above actions are taken, it is recommended to perform a validation procedure (see "Validate the safety functions" on page 78).

Below are some examples of situations where the above conditions are not met (X) and how to properly position the sensor (✓). These examples are not meant to be exhaustive.

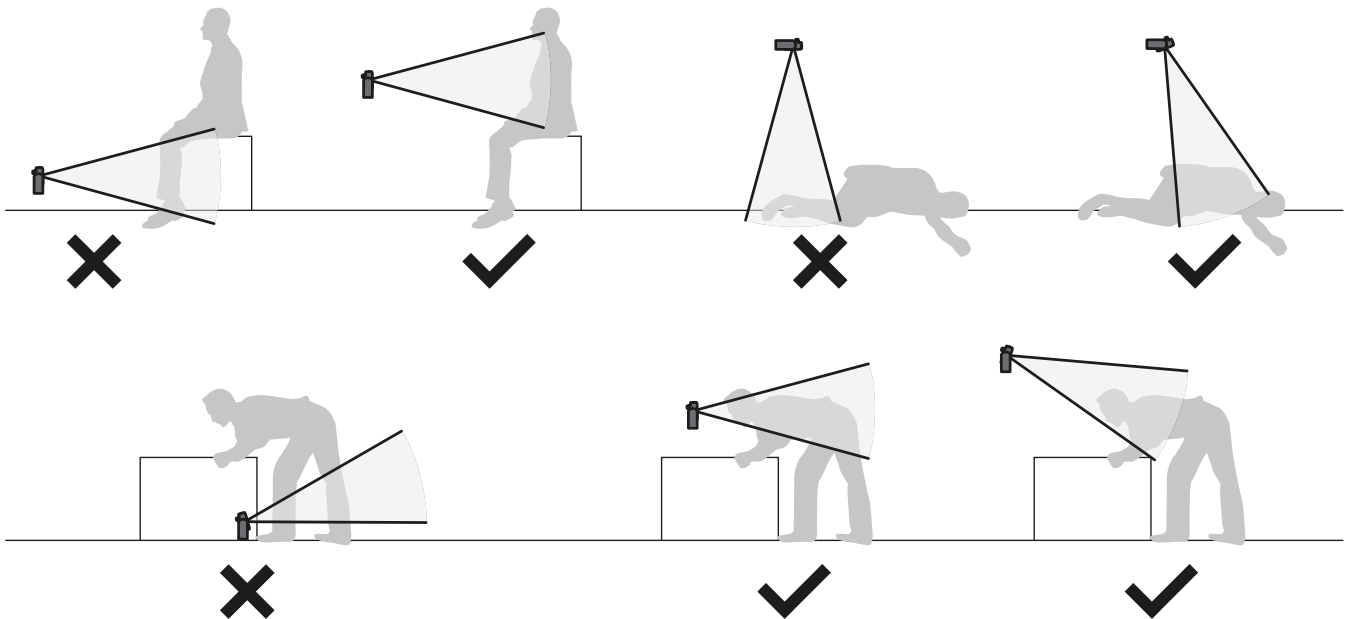

### 5.6.2 Types of managed restart

**NOTICE:** it is the responsibility of the machinery manufacturer to assess if automatic restart can guarantee the same level of safety as manual restart (as defined in standard EN ISO 13849-1:2015, section 5.2.2).

For each detection field independently, the system manages three types of restart:

Type	Conditions for enabling machinery restart	Safety working mode allowed
<b>Automatic</b>	The time interval set through the Inxpect Safety application ( <b>Restart timeout</b> ) has passed since the last motion detection*.	All
<b>Manual</b>	The <b>Restart signal</b> was received correctly** (see "Restart signal (dual channel, redundancy mode coherent)" on page 123).	<b>Always-on access detection</b>

Type	Conditions for enabling machinery restart	Safety working mode allowed
Safe manual	<ul style="list-style-type: none"> <li>The time interval set through the Inxpect Safety application (<b>Restart timeout</b>) has passed since the last motion detection* and</li> <li>The <b>Restart signal</b> was received correctly** (see "Restart signal + System recondition (dual channel, redundancy mode coherent)" on page 126).</li> </ul>	<b>Access detection and restart prevention</b>

 **WARNING! If the Automatic restart is set with the Safety working mode Always-on access detection, the restart prevention safety function is not performed, and consequently, the system does not guarantee the detection of a person within the monitored area.**

**Note\*:** machinery restart is enabled if no motion is detected up to 35 cm (13.8 in) beyond the detection field.

**Note\*\*:** (for all types of restart) other dangerous system statuses may prevent the restart of the machinery (e.g., diagnostic fault, sensor masking, etc.)

### 5.6.3 Precautions for preventing unexpected restarting

To prevent unexpected restarting, if the sensor is installed at a height of less than 15 cm (5.9 in) from the ground to its center, a minimum distance of 50 cm (20 in) from the sensor must be guaranteed.

**Note:** if the sensor is installed at a height of less than 15 cm (5.9 in) from the ground to its center, an option is to enable the masking function to generate a system error if a person stands in front of the sensor.

### 5.6.4 Configure the restart function

 **WARNING! If the Restart signal function has been enabled both through the safety Fieldbus and the digital inputs, the functionality can be activated from both of them.**

Type	Procedure
Automatic	<ol style="list-style-type: none"> <li>In the Inxpect Safety application in <b>Settings &gt; Restart function</b>, select <b>Automatic</b>.</li> <li>In the Inxpect Safety application, in <b>Configuration</b> for each detection field in use with automatic restart, select the desired <b>Safety working mode</b> and set the <b>Restart timeout</b> (or the <b>T<sub>OFF</sub></b> parameter, if present).</li> </ol>
Manual	<ol style="list-style-type: none"> <li>In the Inxpect Safety application in <b>Settings &gt; Restart function</b>, select <b>Manual</b>.</li> <li>If there is a digital input configured as <b>Restart signal (Settings &gt; Digital Input-Output)</b>, connect the machinery button for the restart signal as convenient (see "Electrical connections" on page 108).</li> <li>To use the Fieldbus communication for the restart signal, make sure that no digital input is configured as <b>Restart signal (Settings &gt; Digital Input-Output)</b>. See the Fieldbus protocol for details.</li> <li>In the Inxpect Safety application, in <b>Configuration</b> for each detection field in use with manual restart, set the <b>T<sub>OFF</sub></b> parameter value.</li> </ol> <p><b>Note:</b> the <b>Safety working mode</b> is automatically set to <b>Always-on access detection</b> for all the detection fields in use with manual restart.</p>
Safe manual	<ol style="list-style-type: none"> <li>In the Inxpect Safety application in <b>Settings &gt; Restart function</b>, select <b>Safe manual</b>.</li> <li>If there is a digital input configured as <b>Restart signal (Settings &gt; Digital Input-Output)</b>, connect the machinery button for the restart signal as convenient (see "Electrical connections" on page 108).</li> <li>To use the Fieldbus communication for the restart signal, make sure that no digital input is configured as <b>Restart signal (Settings &gt; Digital Input-Output)</b>. See the Fieldbus protocol for details.</li> <li>In the Inxpect Safety application, in <b>Configuration</b> for each detection field in use with safe manual restart, select the <b>Safety working mode</b> among those allowed and set the <b>Restart timeout</b> parameter value.</li> </ol>

# 6. Other functions

## Contents

This section includes the following topics:

<b>6.1 Muting</b> .....	<b>48</b>
<b>6.2 Anti-tampering functions: anti-rotation around axes</b> .....	<b>49</b>
<b>6.3 Anti-tampering functions: anti-masking</b> .....	<b>50</b>
<b>6.4 Auto-resume (5.x sensors only)</b> .....	<b>52</b>
<b>6.5 Electromagnetic Robustness</b> .....	<b>52</b>

## 6.1 Muting

### 6.1.1 Description

The muting function is an additional safety-related function that inhibits the sensing capability of the sensor on which it is activated. It can be activated for a specific sensor or for a group of sensors. This results in keeping the ON-state of the OSSD or the safety Fieldbus even when the muted sensors detect motion.

When the muting function is enabled, its effective activation on one or more sensors occurs only as soon as the conditions permit (see "Muting" above).

### 6.1.2 Muting enabling

The muting function can be enabled through digital input (see "Enable muting signal characteristics" on the next page) or safety Fieldbus (if available).

 **WARNING! If the muting function has been enabled through the safety Fieldbus and the digital inputs, only the digital inputs enabling is considered for the function.**

 **WARNING! When the sensor is in muting, no sensor error is available (see" ERROR events (sensor)" on page 96.**

Through the safety Fieldbus (if available) the muting function can be enabled for each sensor individually.

Through digital inputs the muting function can be enabled for all the sensors simultaneously or only for a group of sensors. Up to two groups can be configured, each associated with a digital input.

Through the Inxpect Safety application, the following must be defined:

- for each input, the group of managed sensors
- for each group, the sensors that belong to it
- for each sensor, whether it belongs to a group or not

**Note:** if the muting function is enabled for one sensor, it is enabled for all the detection fields of the sensor, regardless if the detection fields are dependent or independent and the anti-tampering functions are disabled for that sensor.

See "Configure the inputs and outputs" on page 77.

### 6.1.3 Muting activation conditions

The muting function is activated on a specific sensor only in the following conditions:

- All the detection fields involved have no active detection signal, no active static object detection signal, and the restart timeout has expired for all of them.
- There is no tampering signal or fault signal for that sensor.

When the muting is enabled for a group of sensors, the function is activated for each sensor as soon as there is no detection in its monitored area, regardless of the status of the other sensors.

 **WARNING! Enable the muting signal on sensors monitoring the same dangerous area once the whole area is safe and nobody can access it. If the muting is enabled when some of the sensors are still detecting a movement, a person could move to a space monitored by a muted sensor, compromising the safety of the whole area.**



### 6.1.4 Enable muting signal characteristics

The muting function is enabled only if both logic signals of the dedicated input meet certain characteristics. Below is a graphic representation of the signal characteristics.

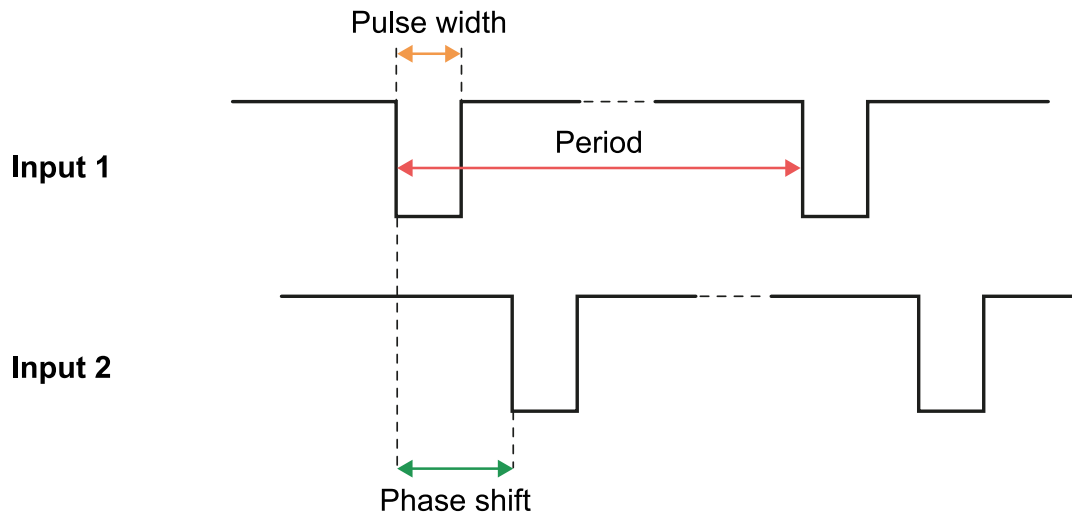

In the **Inxpect Safety** application, in **Settings > Digital Input-Output** it is necessary to set the parameters that define the signal characteristics.

**Note:** with pulse duration = 0, it is sufficient that the input signals are at high logic level (1) to enable muting.

### 6.1.5 Muting status

Any output dedicated to the muting status (Muting enable feedback signal) is activated if at least one of the groups of sensors is in muting.

**NOTICE:** it is the responsibility of the machinery manufacturer to assess whether the indication of the muting status is necessary (as defined in section 5.2.5 of EN ISO 13849-1:2015 standard).

## 6.2 Anti-tampering functions: anti-rotation around axes

### 6.2.1 Anti-rotation around axes

The sensor detects rotation around its axes.

**Note:** the axes are those represented in the figure below, regardless of the installation position of the sensor.

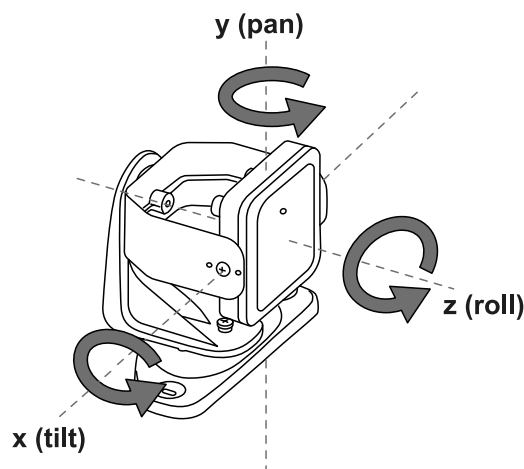

When the system configuration is saved, the sensor also saves its position. Later, if the sensor detects changes in rotation around these axes, it sends a tamper alert to the control unit. Upon reception of a tampering signal, the control unit deactivates the safety outputs.

**Note:** when the position is modified with respect to the saved references (i.e., when a sensor is rotated) and the anti-rotation around axes function is enabled, the Inxpect SRE 200 Series detects the tampering and sends the message within 5 s.

The sensor can detect changes in rotation around the x-axis and the z-axis even if it is switched off. The tamper alert is sent to the control unit at the following switch on.

A change in rotation around the y-axis is detected only if it is faster than 5° every 10 s and if the system is on.



**WARNING! The tamper alert due to a rotation around the y-axis is reset at the next switch on. For proper and safe operation of the system, validate the system again.**

## 6.2.2 Enable the anti-rotation around axes function

The anti-rotation around axes function is disabled by default.



**WARNING! If the function is disabled, the system cannot signal a change in the rotation of the sensor around the axes and, therefore, any changes in the monitored area. See "Checks when the anti-rotation around axes function is disabled" below.**



**WARNING! Take precautions to prevent tampering, if the function is disabled for at least one axis of one sensor and if the rotation around that axis is not protected with tamper-proof screws.**

The function can be enabled and configured for each axis of each sensor individually. In the Inxpect Safety application, in **Settings > Anti-tampering**, click on the specific option to enable the function for a sensor.

## 6.2.3 When to enable

Enable the anti-rotation around axes function only if it is necessary to detect a change in the rotation of a sensor around a specific axis.

It is strongly suggested not to enable the function if the sensor is installed on a moving object (e.g., carriage, vehicle) whose motion could change the sensor inclination (e.g., motion on a slope or in a curve).

## 6.2.4 Checks when the anti-rotation around axes function is disabled

When the anti-rotation around axes function is disabled, perform the following checks.

Safety function	Schedule	Action
Access detection function	Before each machinery restart	Check that the sensor is positioned as defined in the configuration.
Restart prevention function	Each time the safety outputs are deactivated	Check that the monitored area is the same as defined by the configuration. See "Validate the safety functions" on page 78.

## 6.3 Anti-tampering functions: anti-masking

### 6.3.1 Masking signal

The sensor detects the presence of objects that could obstruct the field of view. When the system configuration is saved, the sensor memorizes the surrounding environment. If the sensor subsequently detects variations in the environment that could influence the field of view, it sends a masking signal to the control unit. The sensor monitors from -50° to 50° on the horizontal plane regardless of the angular coverage set. Upon receiving a masking signal, the control unit deactivates the safety outputs.

**Note:** the masking signal is not guaranteed in the presence of objects which cause reflection effects that bring their RCS below the minimum detectable threshold.

**Note:** when the position is modified with respect to the saved references (i.e., when a sensor is masked) and the anti-rotation around axes function is enabled, the Inxpect SRE 200 Series detects the tampering and notifies it within 5 s.

### 6.3.2 Environment memorization process

The sensor starts the surrounding environment memorization process when the Inxpect Safety application configuration is saved. From that moment, it waits for the system to exit the alarm status and for the scene to be static up to 20 seconds, then scans and memorizes the environment.

**NOTICE:** if the scene is not static during the 20 seconds interval, the system remains in a fault status (SIGNAL ERROR) and the system configuration must be saved again.



It is recommended to start the memorization process after at least 3 minutes from turning on the system to guarantee that the sensor has reached the operating temperature.

Only at the conclusion of the memorization process it is possible for the sensor to send masking signals.

### 6.3.3 Causes of masking

Possible causes of masking signals are the following:

- An object that obstructs the field of view of the sensor has been placed in the detection field.
- The environment in the detection field changes significantly, for example, if the sensor is installed on moving parts or if there are moving parts inside of the detection field.
- The configuration was saved with sensors installed in an environment that is different from the working environment.
- There were temperature fluctuations.

### 6.3.4 Masking signal when the system is turned on

If the system was off for several hours and there were temperature fluctuations, the sensor might send a false masking signal when it is turned on. The safety outputs activate automatically within 3 minutes when the sensor reaches its working temperature. This does not happen if this temperature is still very far from the reference temperature.

### 6.3.5 Settings

For each sensor, the anti-masking settings are the following:

- maximum distance from the sensor (range [20 cm/7.87 in, 100 cm/3.28 ft], 10 cm/3.94 in steps) in which the function is active
- sensitivity

These are the four levels of sensitivity:

**Note:** the function has a tolerance area where the actual detection of a masking object depends on the RCS of the object and on the sensitivity level set. The high sensitivity level has the largest area, about 10-20 cm (3.94-7.87 in).

Level	Description	Example application
High	The sensor has the highest sensitivity to changes in the environment. (Suggested level when the field of view is empty up to the set masking distance)	Installations with an empty environment and a height of less than one meter, where objects could occlude the sensor.
Medium	The sensor has low sensitivity to changes in the environment. Occlusion must be evident (deliberate tampering).	Installations with a height of more than one meter, where masking is likely to occur only if voluntary.
Low	The sensor detects masking only if the sensor occlusion is complete and the objects are highly reflective (e.g., metal, water) near the sensor.	Installations on moving parts, where the environment is changing continuously, but where static objects may be near the sensor (obstacles on the route).
Disabled	The sensor does not detect changes in the environment.  <b>WARNING! If the function is disabled the system cannot signal the presence of objects that might impede normal detection (see "Checks when the anti-masking function is disabled" on the next page).</b>	See "When to disable" on the next page.

To change the sensitivity level or disable the function, in the Inxpect Safety application, click **Settings** > **Anti-tampering** and search for **Anti-masking sensitivity**.

To set the distance, in the Inxpect Safety application, click **Settings** > **Anti-tampering** and search for **Anti-masking distance**.

### 6.3.6 Checks when the anti-masking function is disabled

When the anti-masking function is disabled, perform the following checks.

Safety function	Schedule	Action
Access detection function	Before each machinery restart	Remove any objects that obstruct the field of view of the sensor.
Restart prevention function	Each time the safety outputs are deactivated	Reposition the sensor according to the initial installation.

### 6.3.7 When to disable

The anti-masking function should be disabled under the following conditions:

- (With restart prevention function) The monitored area includes moving parts that stop in different and unpredictable positions.
- The monitored area includes moving parts that vary their position while the sensors are in muting.
- The sensor is positioned on a part that can be moved.
- The presence of static objects is tolerated in the monitored area (e.g., loading/unloading area).

## 6.4 Auto-resume (5.x sensors only)

### 6.4.1 Introduction

Some transient faults cause a permanent lock-out condition that prevents normal operation from being restored.

While the safe state is maintained, this behavior represents a limitation, especially for remote systems that are not easily accessible.

The Auto-resume function tries to restore the normal functioning of the sensor for five consecutive attempts: if the fault condition persists, the block condition is preserved. Otherwise, the normal functioning condition is automatically restored.

### 6.4.2 Function limitations

The following faults are not subjected to auto-resume:

- POWER ERROR
- SIGNAL ERROR
- TAMPER ERROR
- TEMPERATURE ERROR

The function is not performed when the sensor is muted.

## 6.5 Electromagnetic Robustness

### 6.5.1 Electromagnetic robustness parameter

With the **Electromagnetic robustness** parameter, it is possible to increase the robustness of the system to electromagnetic interference (e.g., due to sensors of different systems installed too close to each other or problems on the CAN bus).

In the Inxpect Safety application in **Settings** > **Advanced**, the following levels of robustness can be set:

- Standard (default)
- High
- Very High



**WARNING!** The parameter impacts the system response time for the access detection safety function. According to the chosen level, the maximum guaranteed response time is 100 ms (Standard level), 150 ms (High level), or 200 ms (Very High level).

# 7. Sensor position

## Contents

This section includes the following topics:

7.1 Basic concepts .....	53
7.2 Sensor field of view .....	53
7.3 Advanced field of view (5.x sensors only) .....	57
7.4 Dangerous area calculation .....	58
7.5 Calculation of range of distances .....	60
7.6 Sensor position recommendations .....	61
7.7 Installations on moving elements (Mobile application) .....	63
7.8 Outdoor installations .....	64

## 7.1 Basic concepts

### 7.1.1 Determining factors

The sensor installation height and inclination should be decided together with the angular coverage and the detection distances in order to have optimal coverage of the dangerous area.

### 7.1.2 Sensor installation height

The installation height ( $h$ ) is the distance between the center of the sensor and the ground or reference plane of the sensor.

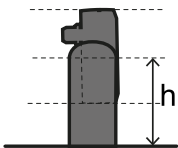

### 7.1.3 Sensor inclination

Sensor inclination is the rotation of the sensor around its x-axis. Inclination is defined as the angle between a line perpendicular to the sensor and a line parallel to the ground. Three examples are presented as follows:

- sensor tilted upwards:  $\alpha$  positive
- straight sensor:  $\alpha = 0$
- sensor tilted downwards:  $\alpha$  negative

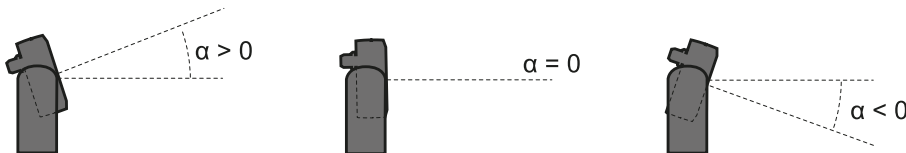

## 7.2 Sensor field of view

### 7.2.1 Types of field of view

During the configuration phase, for each sensor it is possible to select the angular coverage (see "Angular coverage" on page 38).

The actual detection field of the sensor also depends on the sensor installation height and inclination. See "Calculation of range of distances" on page 60.

The standard shapes of the field of view are described below. For 5.x sensors, the Classic and Corridor shapes are available, see "Advanced field of view (5.x sensors only)" on page 57.

### 7.2.2 Areas and dimensions of the field of view

The sensor field of view is composed of two areas:

- detection field **[A]**: where detection of objects similar to humans in any position is guaranteed
- tolerance area **[B]**: where the actual detection of a moving object/person depends on the characteristics of the object itself (see "Factors that influence the reflected signal" on page 37)

### 7.2.3 Dimensions for the access detection function

**Note:** the tolerance area dimensions described are related to the detection of humans.

The horizontal tolerance area is 20° greater than the angular coverage set.

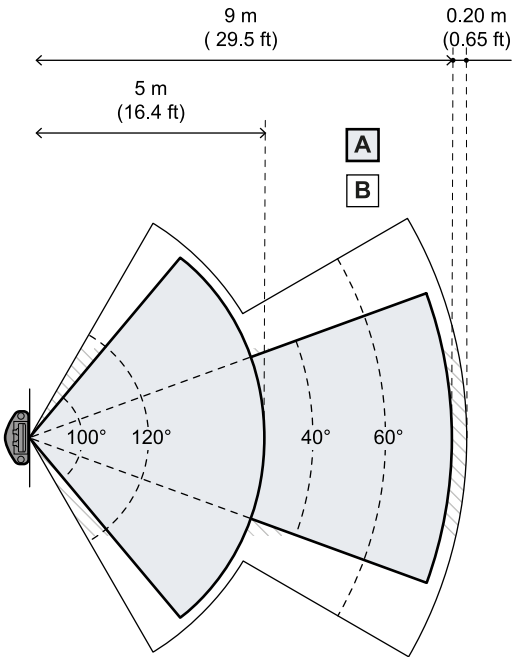

Top view S201A-MLR

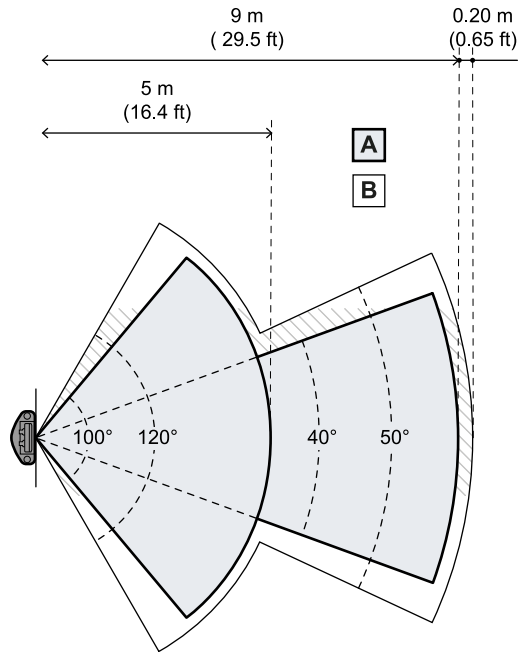

Top view S201A-WL, S203A-WL

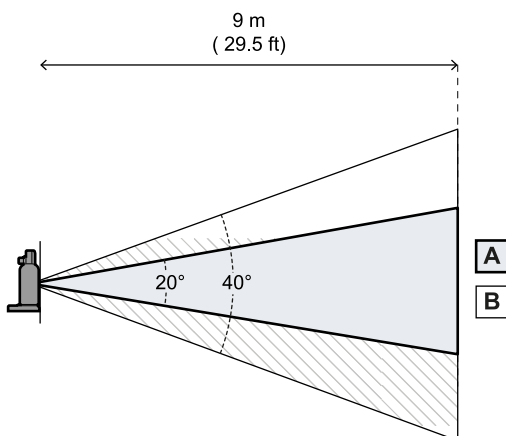

Side view S201A model

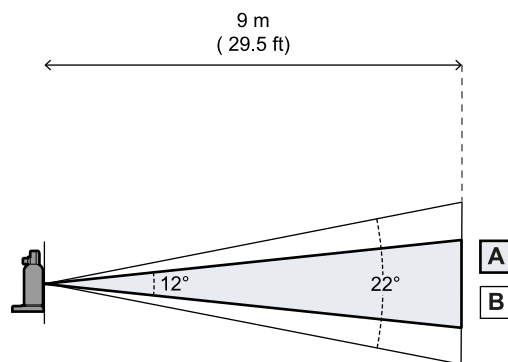

Side view S203A model

## 7.2.4 Dimensions for the restart prevention function

**Note:** the tolerance area dimensions described are related to the detection of humans.

The horizontal tolerance area is 40° greater than the angular coverage set.

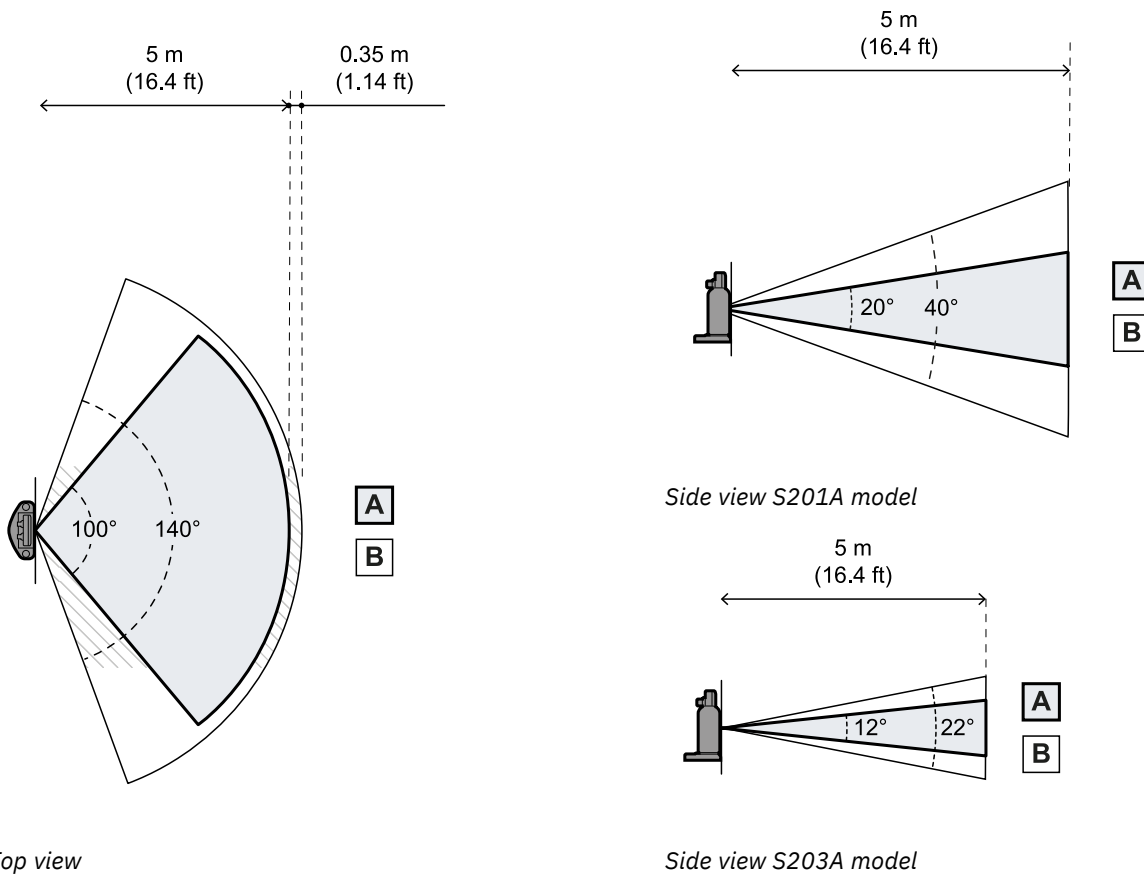

## 7.2.5 Position of the field of view

The field of view is tilted of the following degrees:

- 2.5° for S201A model
- 1° for S203A model

To understand the actual position of the sensor field of view consider the LED position:

- left with sensor LED on the right (with respect to the sensor center, facing the sensor)
- right with sensor LED on the left (with respect to the sensor center, facing the sensor)
- downward with sensor LED up

**Offset 2.5°**

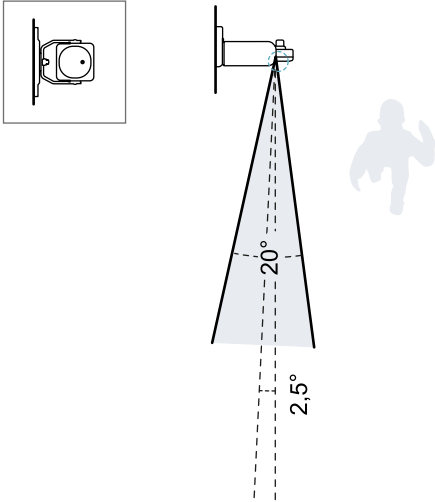

Top view with sensor inclination 0°.

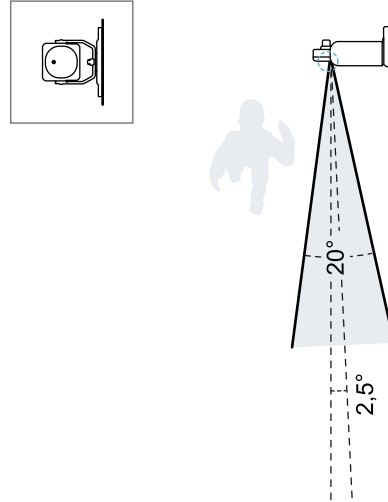

Top view with sensor inclination 0°.

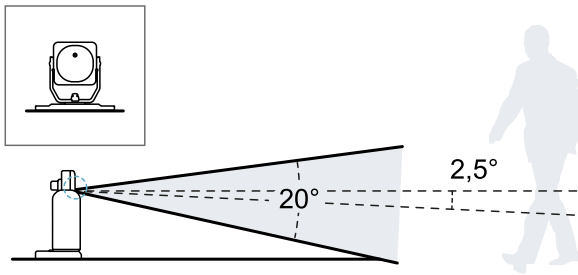

Side view with sensor inclination 0°.

**Offset 1°**

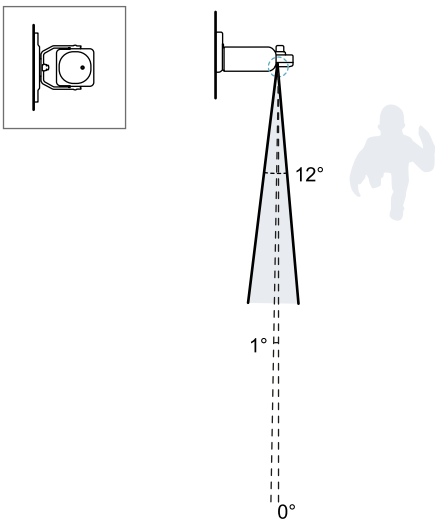

Top view with sensor inclination 0°.

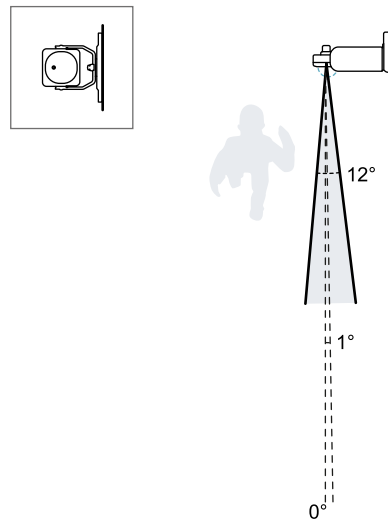

Top view with sensor inclination 0°.



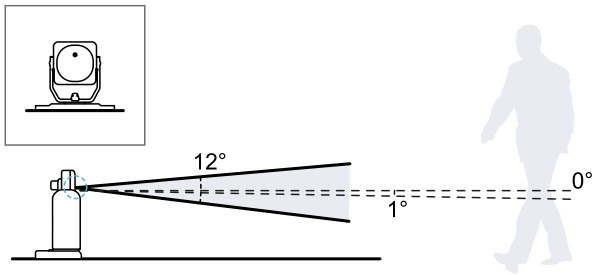

Side view with sensor inclination 0°.

## 7.3 Advanced field of view (5.x sensors only)

### 7.3.1 Introduction

For each sensor, two field of view shapes are available:

- Classic
- Corridor

### 7.3.2 Classic field of view

The classic shape allows you to choose the standard shape of the field of view and, if desired, to make it asymmetric. Each detection field can have its own symmetric/asymmetric angular coverage.

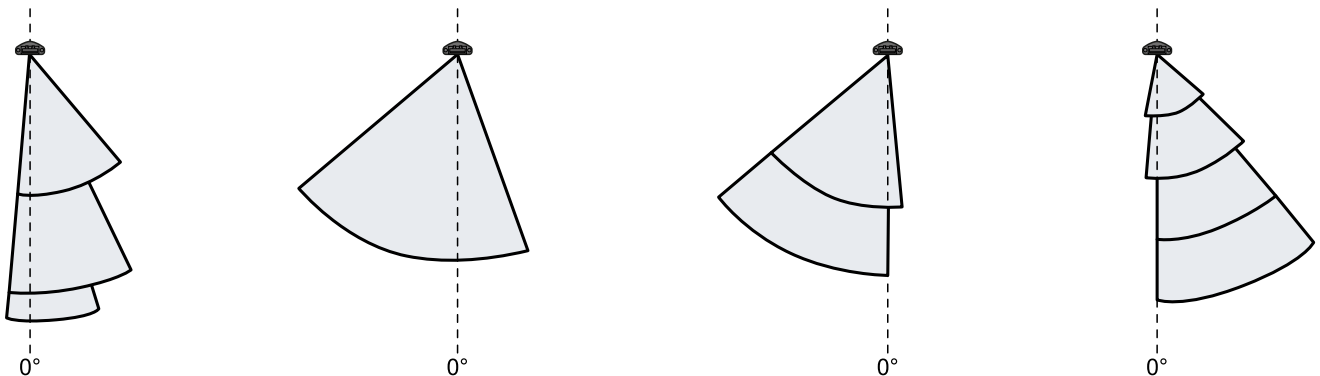

Conditions:

- The sensor axis must always be included in all the detection fields.
- The angular coverage of each detection field must be wider than, or equal to, the angular coverage of the following detection fields.
- The minimum field of view width is 10°.

### 7.3.3 Corridor field of view

The corridor shape allows to customize the shape of the field of view. Starting from the standard shape with maximum angular coverage, it is possible to crop it on the side with two flat surfaces parallel to the axis of the sensor. Each detection field can have its own corridor width.

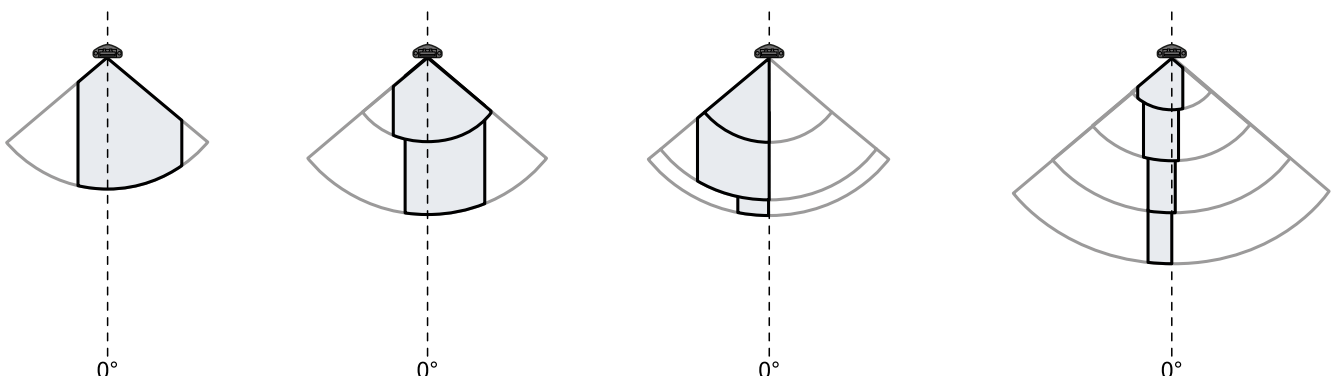

Conditions:

- The sensor axis must always be included in all the detection fields.
- The angular coverage of each detection field must be wider than, or equal to, the angular coverage of the following detection fields.
- The minimum corridor width is 20 cm (7.87 in).
- The minimum corridor width is:
  - 20 cm (7.87 in) in the first 5 m (16.4 ft) of the field of view
  - 30 cm (11.81 in) from 5 to 9 m (from 16.4 to 29.5 ft) of the field of view

## 7.4 Dangerous area calculation

### 7.4.1 Introduction

The dangerous area of the machinery to which Inxpect SRE 200 Series is applied must be calculated according to the formulas described in this section, which are defined considering the guidelines and requirements of the ISO 13855:2010 (and ISO DIS 13855) standard.

### 7.4.2 Formula for stationary application

To calculate the depth of the dangerous area (S) for stationary applications, use the following formula:

$$S = K * T + C$$

Where:

Variable	Description	Value	Measurement unit
<b>K</b>	Maximum dangerous area access speed	1600	mm/s
<b>T</b>	Total system stopping time (Inxpect SRE 200 Series + machinery)	0.1 + Machinery stopping time (calculated in accordance with standard ISO 13855:2010)	s
<b>C</b>	Corrective value	If $H \leq 1000$ , $C = 1200$	mm
		If $1000 < H < 1400$ , $C = 1200 - [(H - 1000) * 0.875]$	mm
		If $H \geq 1400$ , $C = 850$	mm
		For more details about H, see "H dimension definition" on the next page.	

**Note:** when using Fieldbus, add the communication and processing time required for the signal to reach the machine after the safety output is activated.

#### Example 1

- Machinery stopping time = 0.5 s
- $H \geq 1400$

$$T = 0.1 \text{ s} + 0.5 \text{ s} = \mathbf{0.6 \text{ s}}$$

$$S = 1600 * \mathbf{0.6} + \mathbf{850} = \mathbf{1810 \text{ mm}}$$

#### Example 2

- Machinery stopping time = 0.3 s
- $H = 1200$

$$T = 0.1 \text{ s} + 0.3 \text{ s} = \mathbf{0.4 \text{ s}}$$

$$C = 1200 - [(1200-1000)* 0.875] = 1025 \text{ mm}$$

$$S = 1600 * \mathbf{0.4} + \mathbf{1025} = \mathbf{1665 \text{ mm}}$$

### 7.4.3 H dimension definition

According to the approach, the H dimension has to be considered in the following way:

- for the parallel approach, H is the upper edge of the detection field **[A]**
- for the orthogonal approach, H is the highest point of intersection between the detection field and the body of a standing person, defined in the worst-case penetration position **[B], [C], [D]**

**Note:** **[A], [B], [C]** and **[D]** are examples to define H and not suggestions on how to install the sensor. For details about the calculation of H, please refer to the application notes downloadable from the site <https://tools.inxpect.com>. For details about the difference between the two approaches, please refer to standard ISO 13855.

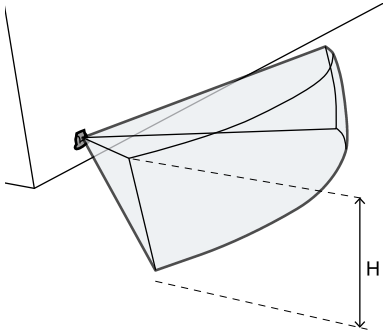

[A]

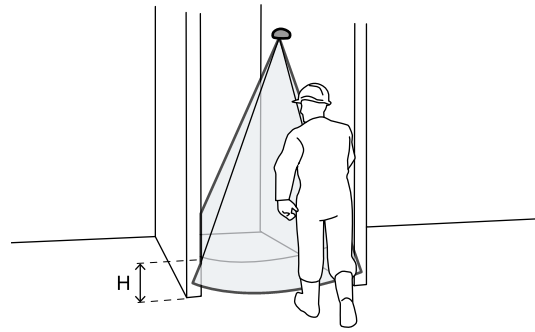

[B]

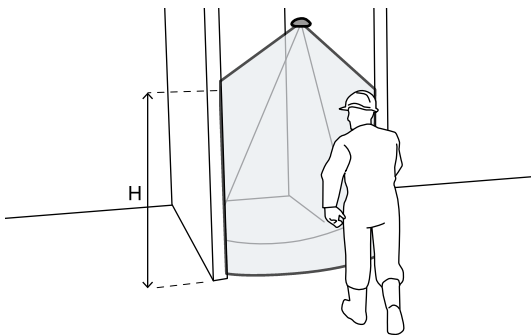

[C]

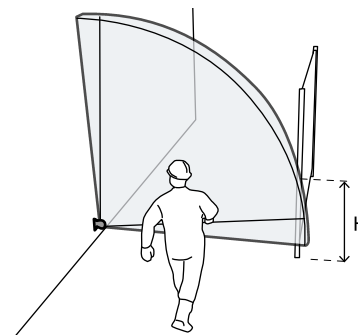

[D]

### 7.4.4 Formula for mobile application

To calculate the depth of the dangerous area (S) for mobile applications, use the following formula:

$$S = K * T + C$$

Where:

Variable	Description	Value	Measurement unit
<b>K</b>	Maximum vehicle/part of machinery speed *.	≤ 4000	mm/s
<b>T</b>	Total system stopping time (Inxpect SRE 200 Series + machinery)	0.1 + Machinery stopping time (calculated in accordance with standard ISO 13855:2010)	s
<b>C</b>	Corrective value	200	mm

**Note\*:** only the speed of the vehicle or of the part of machinery is considered. This is based on the assumption that the person recognizes the hazard and stands still.

**Note:** when using Fieldbus, add the communication and processing time required for the signal to reach the machine after the safety output is activated.

## Example 2

- maximum vehicle speed = 2000 mm/s
- machinery stopping time = 0.5 s

$$T = 0.1 \text{ s} + 0.5 \text{ s} = \mathbf{0.6 \text{ s}}$$

$$S = 2000 * \mathbf{0.6} + 200 = \mathbf{1400 \text{ mm}}$$

## 7.5 Calculation of range of distances

### 7.5.1 Introduction

The range of detection distances for a sensor depends on the inclination ( $\alpha$ ) and the installation heights ( $h$ ) of the sensor. The detection distance of each detection field (**Dalarm**) depends on a distance  $d$  that must be within the range of distances allowed.

The formulas for calculating the distances are reported as follows.



**WARNING! Define the optimum sensor position according to the risk assessment requirements.**

### 7.5.2 Legend

Element	Description	Measurement unit
$\alpha$	Sensor inclination	degrees
$h$	Sensor installation height	m
$d$	Detection distance (linear) Must be within the range of distances allowed (see "Installation configurations" below).	m
<b>Dalarm</b>	Detection distance (real)	m
<b>D<sub>1</sub></b>	Start detection distance (for configuration 2 and 3); end detection distance (for configuration 1)	m
<b>D<sub>2</sub></b>	End detection distance (for configuration 3)	m

### 7.5.3 Installation configurations

For the S201A model, three configurations are possible based on the inclination of the sensor ( $\alpha$ ):

- $\alpha \geq +13^\circ$ : configuration 1, the field of view of the sensor never intersects the ground
- $-7^\circ \leq \alpha \leq +12^\circ$ : configuration 2, the upper portion of the field of view of the sensor never intersects the ground
- $\alpha \leq -8^\circ$ : configuration 3, the upper portion and the bottom portion of the field of view always intersect the ground

For the S203A model, three configurations are possible based on the inclination of the sensor ( $\alpha$ ):

- $\alpha \geq +8^\circ$ : configuration 1, the field of view of the sensor never intersects the ground
- $-5^\circ \leq \alpha \leq +7^\circ$ : configuration 2, the upper portion of the field of view of the sensor never intersects the ground
- $\alpha \leq -6^\circ$ : configuration 3, the upper portion and the bottom portion of the field of view always intersect the ground

**Note:** the positive sign (+) indicates the tilt up, while the negative sign (-) the downward tilt.

### 7.5.4 Calculate the range of distances

The range of detection distances for a sensor depends on the configuration:

Configuration	Range of distances
1	From 0 m to $D_1$
2	From $D_1$ to 9 m
3	From $D_1$ to $D_2$

For S201A model:

$$D_1 = \frac{h-0.2}{\tan((-\alpha)+2.5^\circ+10^\circ)}$$

$$D_2 = \frac{h-0.6}{\tan((-\alpha)+2.5^\circ-10^\circ)}$$

For S203A model:

$$D_1 = \frac{h-0.2}{\tan((-\alpha)+1^\circ+6^\circ)}$$

$$D_2 = \frac{h-0.6}{\tan((-\alpha)+1^\circ-6^\circ)}$$

Below is an example for configuration 3, with  $D_1 = 0.9$  m and  $D_2 = 1.6$  m.

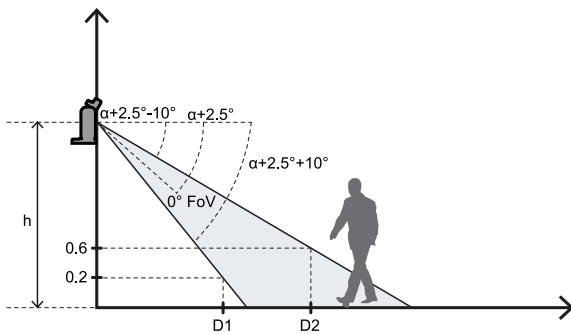

S201A model

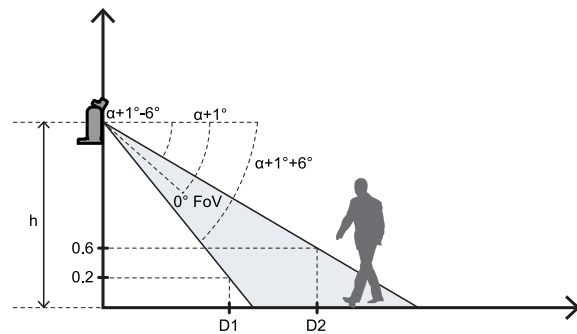

S203A model

## 7.5.5 Calculate the real detection distance

The actual detection distance **Dalarm** is the value to be entered on the **Configuration** page of the Inxpect Safety application.

**Dalarm** indicates the maximum distance between the sensor and the object to be detected.

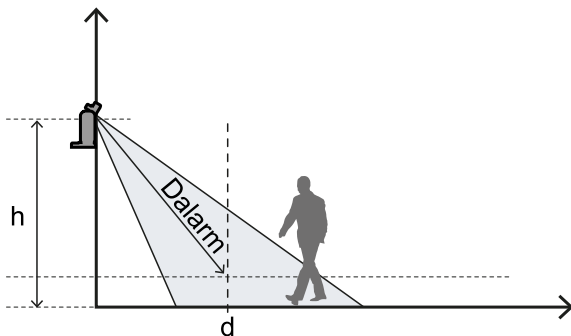

$$D_{alarm} = \sqrt{d^2 + (h - 0.2)^2}$$

## 7.6 Sensor position recommendations

### 7.6.1 For access detection function

Below are some recommendations for the sensor positioning for the access detection function:

- If the distance between the ground and the bottom portion of the field of view is greater than 20 cm (7.9 in), take precautions to make sure that even a person entering the dangerous area below the volume monitored by the field of view is still detected.
- If the height above the ground is less than 20 cm (7.9 in), install the sensor with an inclination of minimum 10° upwards.
- The installation height (from the ground to the center of the sensor) must be greater than or equal to 15 cm (5.9 in).

### 7.6.2 For access control of an entrance

Below are some recommendations for the sensor positioning if it is installed for controlling an entrance:

- The installation height (from the ground to the center of the sensor) must be greater than or equal to 20 cm (7.9 in).
- The angular coverage must be 90°.
- The inclination must be 40° upwards.
- The rotation around the z-axis must be 90°.

Below is an example:

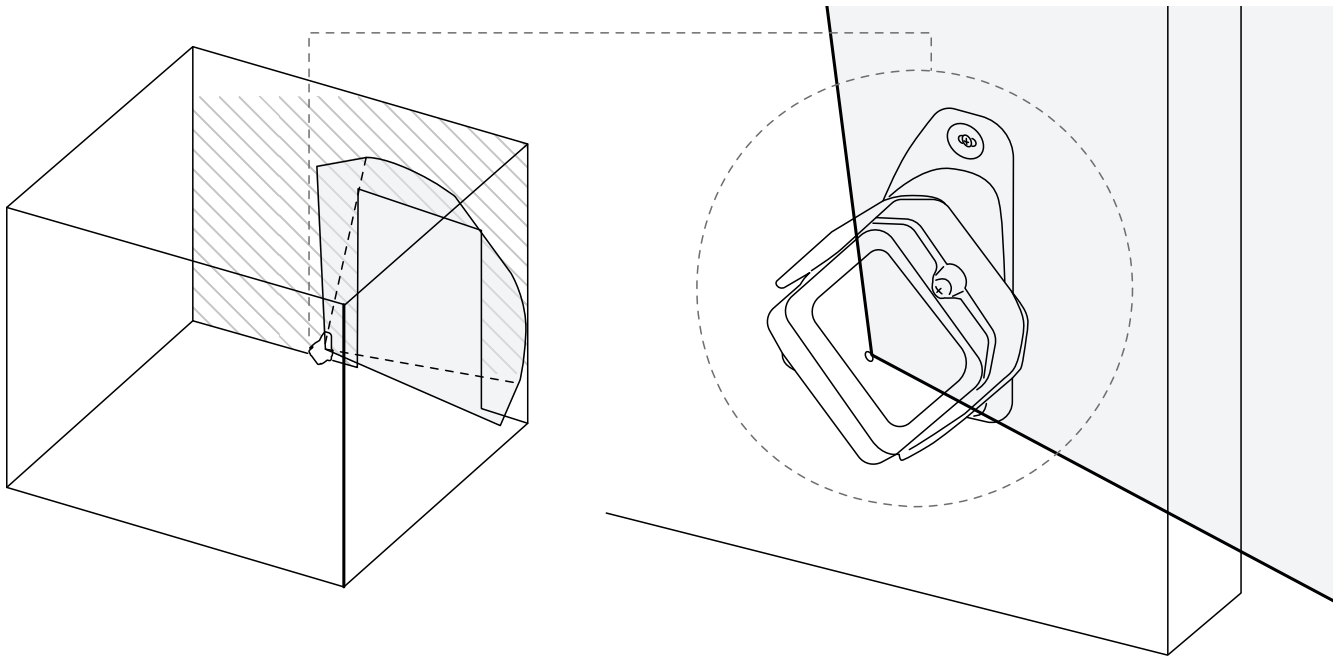

**WARNING!** The angular coverage in the first 800 mm (31.5 in) of the field of view must be at least 60°. If this specification cannot be respected, take precautions to avoid the access of a human in the first 800 mm (31.5 in) of the field of view.

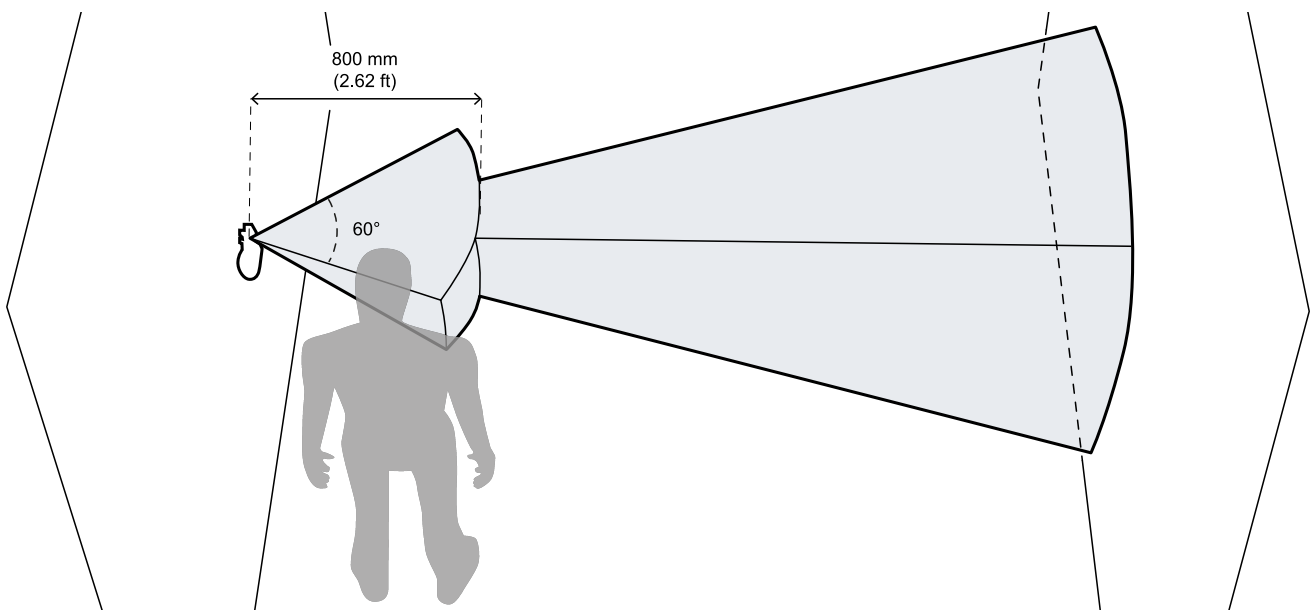

### 7.6.3 For restart prevention function

Below are some recommendations for the sensor positioning for the restart prevention function:

- The installation height (from the ground to the center of the sensor) must be greater than or equal to 15 cm (5.9 in).

## 7.7 Installations on moving elements (Mobile application)

### 7.7.1 Introduction

The sensors can be mounted on moving vehicles or moving machinery parts.

The characteristics of the detection field and the response time are the same as in stationary installations.

### 7.7.2 Speed limits

The detection is guaranteed only if the speed of the vehicle or part of the machinery is from 0.1 m/s (0.33 ft/s) to 4 m/s (13.12 ft/s).

**Note:** only the speed of the vehicle or of the part of machinery is considered. This is based on the assumption that the person recognizes the hazard and stands still.

### 7.7.3 Detection signal generation conditions

When the sensor is mounted on moving parts, it will detect static objects as moving objects.

The sensor will trigger a detection signal if the following conditions are met:

- For Human detection (**RCS Threshold** equal to 0 dB), the RCS (Radar Cross-Section) of one or more static objects is greater than or equal to the RCS of a human body.
- For Custom target detection (**RCS Threshold** greater than 0 dB), the RCS of one or more static objects is greater than or equal to the RCS value set in **RCS Threshold**.
- The relative speed between the objects and the sensor is greater than the minimum speed necessary for detection.

### 7.7.4 Prevention of unexpected restart

As for stationary installations, when the moving part where the sensor is installed is arrested because of detection, the system will switch to restart prevention safety function (if **Safety working mode** is not **Always-on access detection**), and the sensor will detect the presence of a human body (see "Sensor positioning guidelines" on page 46). Static objects are then automatically filtered out and no longer detected.

The restart of the moving vehicle or moving part of the machinery in the presence of static objects can be prevented using the following methods:

- Static object detection option enabled (see "Restart prevention function: static object detection option" on page 45).
- Anti-masking function: if the function is enabled, an error will occur when the static object will be close enough to limit the detection of the sensor.  
**Note:** if the anti-masking function is active when the sensor is moving also, this could generate false alarms since the environment change during movement could be detected as tampering.
- Manual restart: the restart is triggered externally and only once the static object is removed from the trajectory of the moving vehicle or moving part.
- Application logic on PLC/control unit that permanently stops the moving part if multiple stops occur immediately after the restart of the part. If the vehicle or the part stops very quickly after the restart, this probably means that there is a static obstacle. Once the moving part is stopped, the sensor does not detect the object anymore and therefore the part moves but it stops again as soon as it detects the object again.

### 7.7.5 Recommendations for positioning the sensor

In mobile applications, the sensor moves with the vehicle or moving machinery parts. Position the sensor so the floor is excluded from its detection field to avoid undesired alarms.

For driverless industrial trucks in indoor environments, it is recommended to use a S203A model sensor and install it so that the center of the sensor is positioned at a height of 15 cm (5.9 in) from the ground, with an inclination of no more than 7° upward.

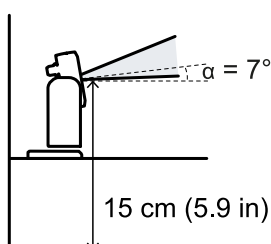

## 7.8 Outdoor installations

### 7.8.1 Position exposed to precipitation

If the sensor installation position might be exposed to precipitation that can cause undesired alarms, it is recommended to take the following precautions:

- Make a cover to protect the sensor from rain, hail or snow.
- Position the sensor so that it does not frame the ground where puddles might form.

**NOTICE:** Weather conditions outside specifications can prematurely age the device.

### 7.8.2 Recommendations for covering the sensor

Below are some recommendations for creating and installing a sensor cover:

- height from sensor: 15 cm (6 in)
- width: minimum 30 cm (11.8 in), maximum 40 cm (15.7 in)
- protrusion from the sensor: minimum 15 cm (6 in), maximum 20 cm (7.9 in)
- water outflow: at the sides or behind but not in front of the sensor (the cover should be arched and/or tilted backwards)

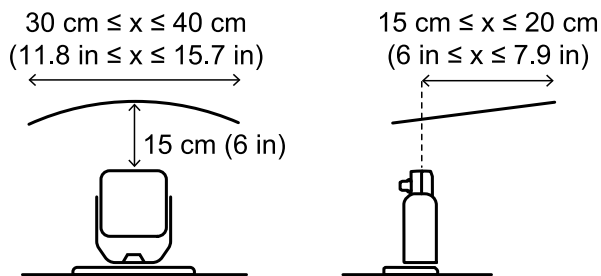

### 7.8.3 Recommendations for positioning the sensor

Below are some recommendations for defining the sensor position:

- installation height (from the ground to the center of the sensor): minimum 15 cm (5.9 in)
- suggested inclination: minimum 15° for S201A model, 10° for S203A model

Before installing a sensor facing downwards, make sure there are neither liquids nor radar reflective materials on the floor.

**Note:** if the above recommendations are followed and the monitored area is free of static objects, the system is robust against a rainfall rate up to 45 mm/h.

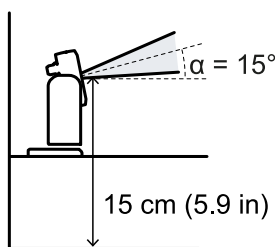

### 7.8.4 Position not exposed to precipitation

If the installation position of the sensor is not exposed to precipitation, no special precautions are required.



# 8. Installation and use procedures

---

## Contents

This section includes the following topics:

<b>8.1 Before installation</b> .....	<b>65</b>
<b>8.2 Install Inxpect SRE 200 Series</b> .....	<b>65</b>
<b>8.3 Set the sensor inclination with a 1° precision</b> .....	<b>73</b>
<b>8.4 Configure Inxpect SRE 200 Series</b> .....	<b>76</b>
<b>8.5 Validate the safety functions</b> .....	<b>78</b>
<b>8.6 Manage the configuration</b> .....	<b>82</b>
<b>8.7 Other procedures</b> .....	<b>83</b>

## 8.1 Before installation

---

### 8.1.1 Materials required

- Two tamper-proof screws (see "Tamper-proof screws specifications" on page 105) to mount each sensor.
- Cables to connect the control unit to the first sensor and the sensors to one another (see "CAN bus cables recommended specifications" on page 105).
- A data USB cable with a micro-USB connector (micro-B type) or, only if the Ethernet port is available, an Ethernet cable to connect the control unit to the computer.
- A bus terminator (product code: 07000003) with resistance of 120 Ω for the last sensor of the CAN bus.
- A screwdriver for tamper-proof screws (see "Tamper-proof screws specifications" on page 105) to be used with the Hex pin security bit supplied in the control unit package.

### 8.1.2 Operating system required

- Microsoft Windows 10 or later
- Apple OS X 11.0 or later

### 8.1.3 Install the Inxpect Safety application

**Note:** if the installation fails, the dependencies needed by the application may be missing. Update your operating system or contact our Technical Support to receive assistance.

1. Download the application from the <https://tools.inxpect.com> website and install it on the computer.
2. With Microsoft Windows operating system, download and install from the same site also the driver for USB connection.

### 8.1.4 Initiate Inxpect SRE 200 Series

1. Calculate the position of the sensor (see "Sensor position" on page 53) and the depth of the dangerous area (see "Dangerous area calculation" on page 58).
2. "Install Inxpect SRE 200 Series".
3. "Configure Inxpect SRE 200 Series".
4. "Validate the safety functions".

## 8.2 Install Inxpect SRE 200 Series

---

### 8.2.1 Install procedure

1. "Install the control unit".
2. Optional. "Mount 3-axes bracket".
3. "Install the sensors".
4. "Connect the sensors to the control unit".

**Note:** connect the sensors to the control unit off-site if access to the connectors becomes difficult once installed.

## 8.2.2 Install the control unit



**WARNING!** To prevent tampering, make sure the control unit is only accessible to authorized personnel (e.g., key-locked electrical panel)

1. Mount the control unit on the DIN rail.
2. Make electrical connections (see "Terminal blocks and connector pin-outs" on page 106 and "Electrical connections" on page 108).

**NOTICE:** if at least one input is connected, the SNS input "V+ (SNS)" and the GND input "V- (SNS)" must also be connected.

**NOTICE:** when powered, the system takes about 20 s to start. During that period, the outputs and the diagnostic functions are deactivated, and the green sensor status LEDs of the connected sensors flash.

**NOTICE:** make sure to avoid any EMC interference during the control unit installation.

**Note:** to correctly connect the digital inputs, see "Voltage and current limits for digital inputs" on page 106.

### 8.2.3 Mount 3-axes bracket

**Note:** for an example of sensor installation, see "Examples of sensor installation" on page 70.

The bracket that allows rotation around the z-axis (roll) is an accessory in the package. To mount it:

1. Unscrew the screw at the bottom and remove the bracket with the sensor and the aligning ring.
2. Attach the roll bracket to the base. Use the tamper-proof screw provided with the bracket.

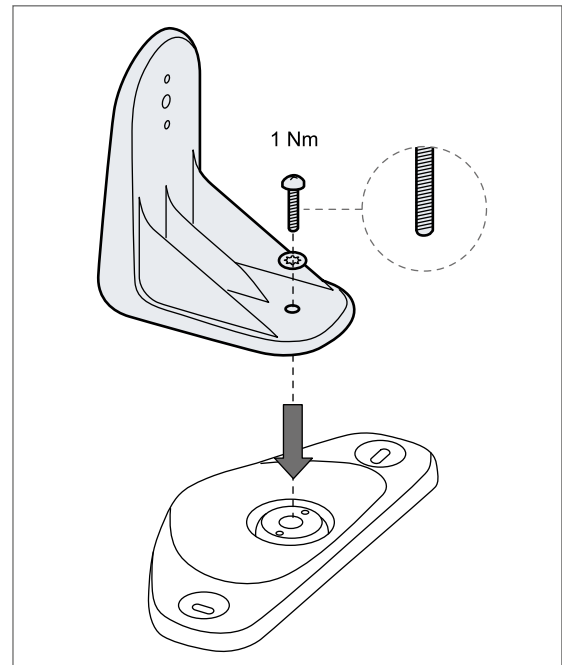
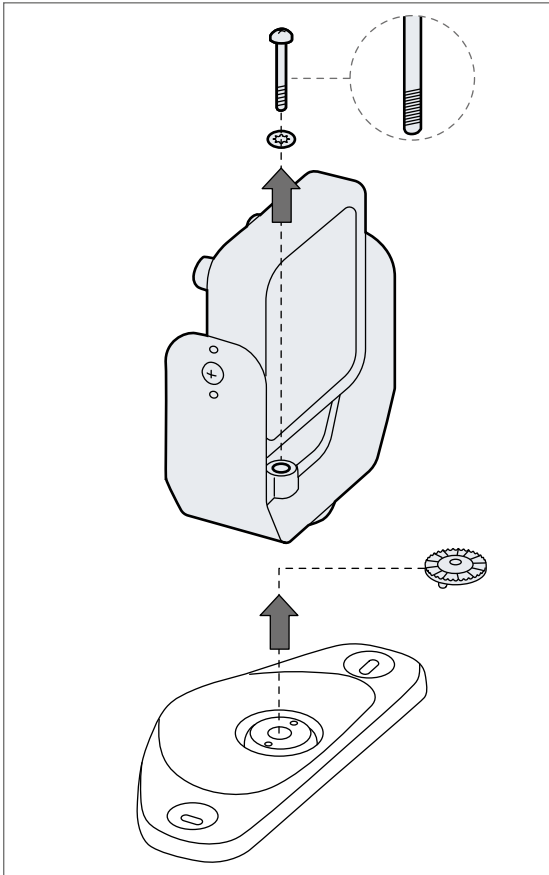

3. Mount the bracket with the sensor and the aligning ring. Use the tamper-proof screw provided with the bracket.

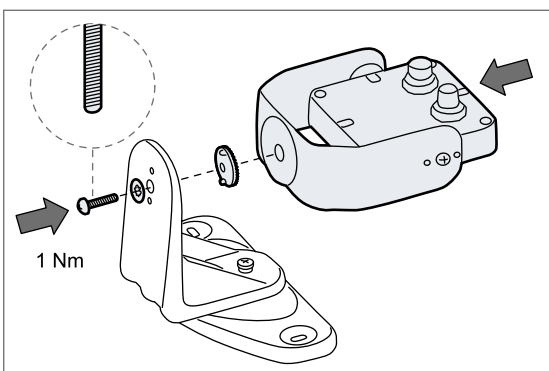

## 8.2.4 Install the sensors

**Note:** for an example of sensor installation, see "Examples of sensor installation" on page 70.

**Note:** the usage of a thread-locking fluid on the threads of fasteners is suggested, especially when the sensor is installed on a moving or vibrating part of the machinery.

**Note:** if no bracket is used for sensor installation, use tamper-proof screws and threadlocker.

1. Position the sensor as indicated in the configuration report and fasten the bracket with two tamper-proof screws directly onto the floor or another support.

**NOTICE:** make sure the support does not inhibit machinery commands.

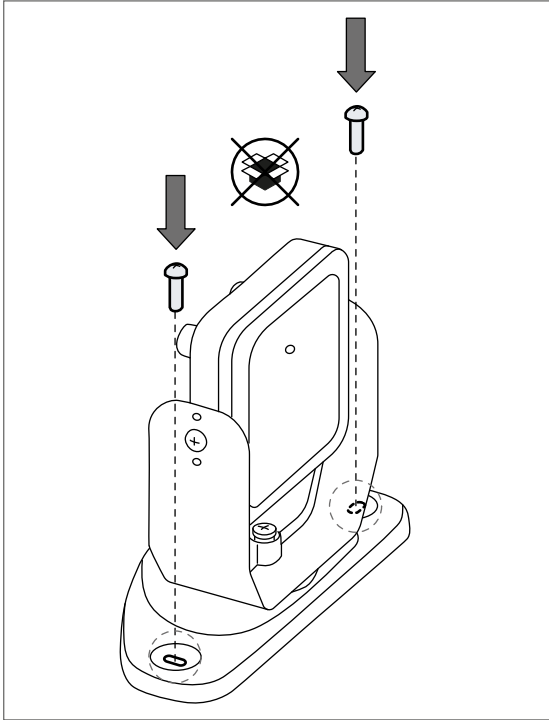

2. With an Allen key, loosen the screw at the bottom to pan the sensor.

**Note:** to avoid damaging the bracket, loosen the screw completely before panning the sensor.

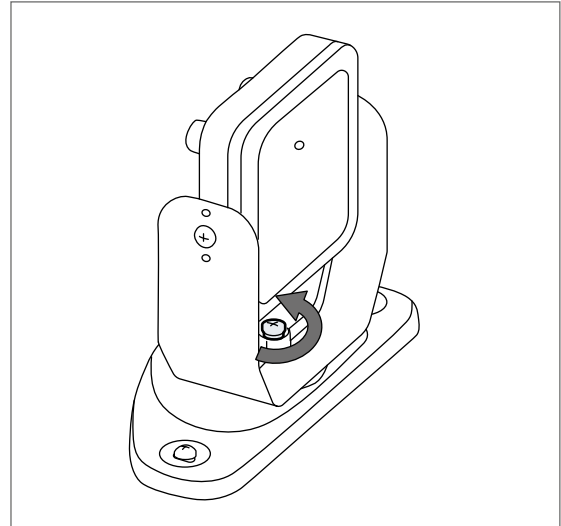

3. Pan the sensor until it reaches the desired position.

**Note:** a notch is equal to a 10° of rotation.

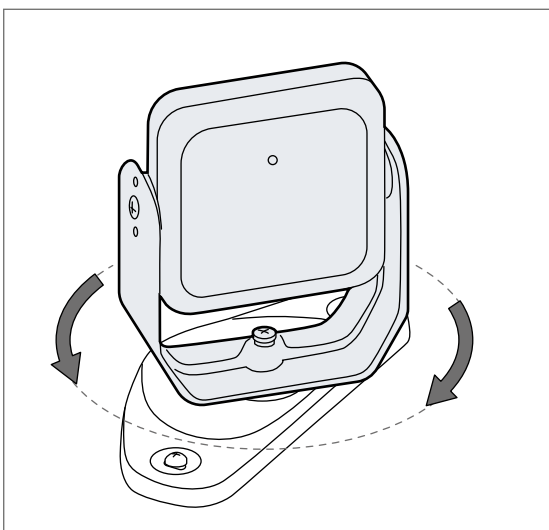

4. Tighten the screw.

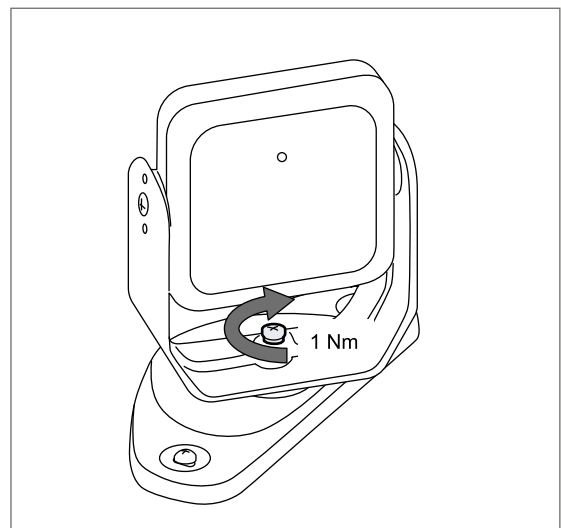

5. Loosen the tamper-proof screws to tilt the sensor.

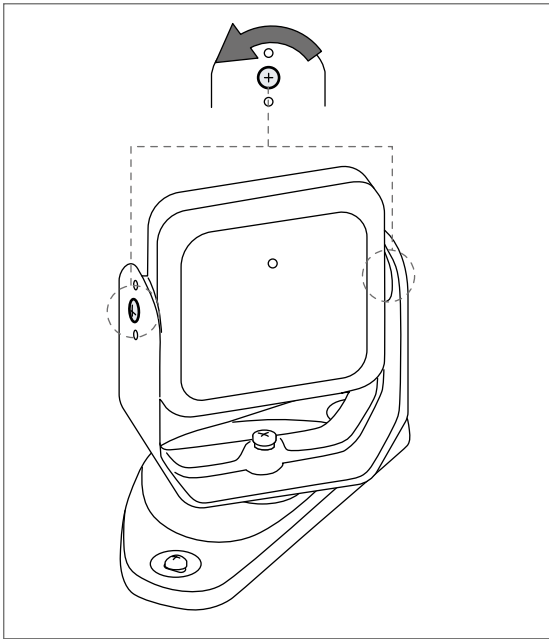

6. Tilt the sensor to the desired inclination (see "Sensor position" on page 53).

**Note:** a notch is equal to a 10° of inclination.  
For a finer regulation of the sensor inclination with a 1° precision (see "Set the sensor inclination with a 1° precision" on page 73).

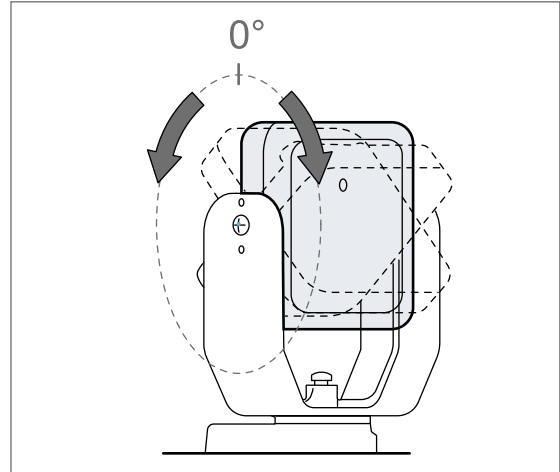

7. Tighten the screws.

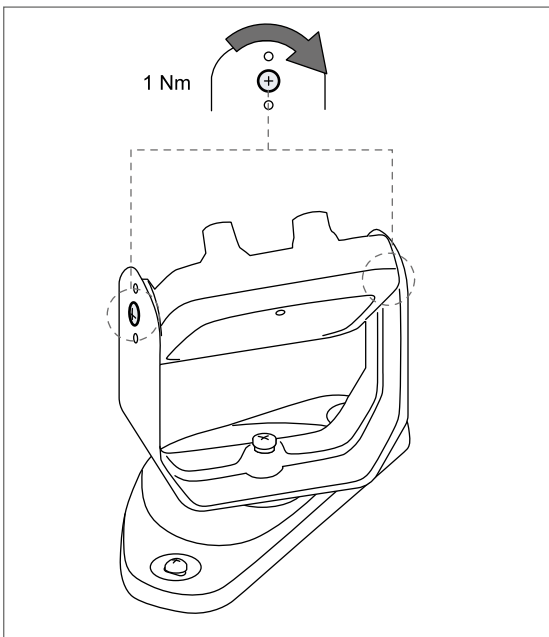

### 8.2.5 Examples of sensor installation

**NOTICE:** refer to the sensor LED position to identify the sensor field of view (see "Position of the field of view" on page 55).

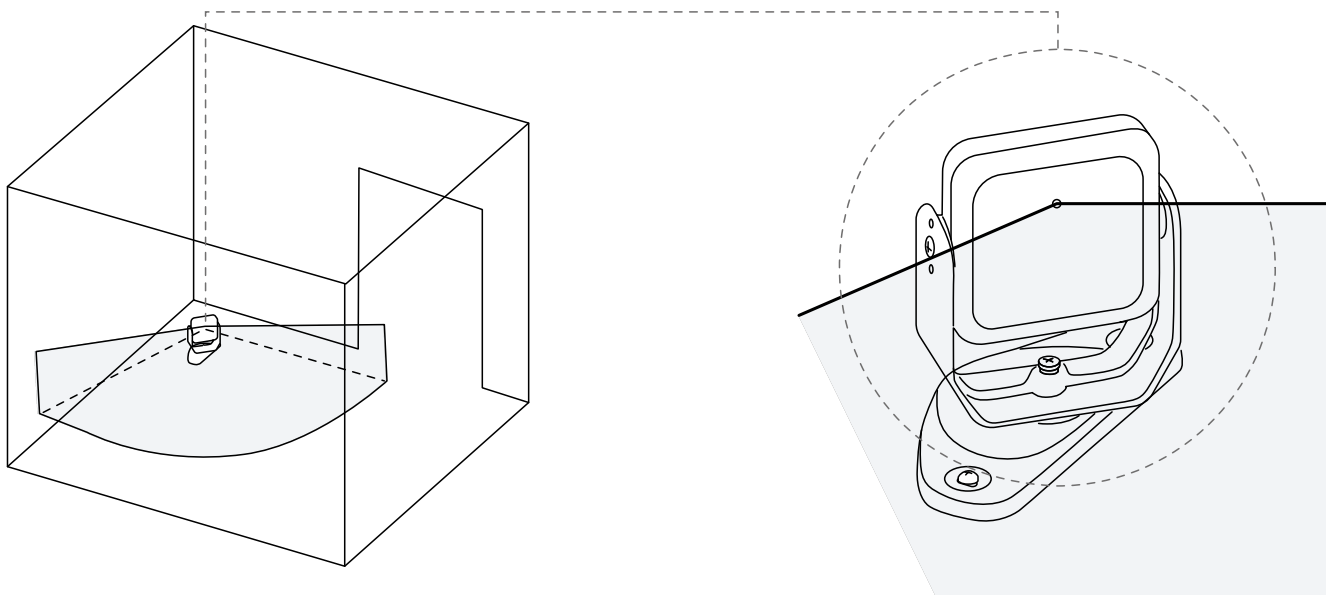

Floor installation

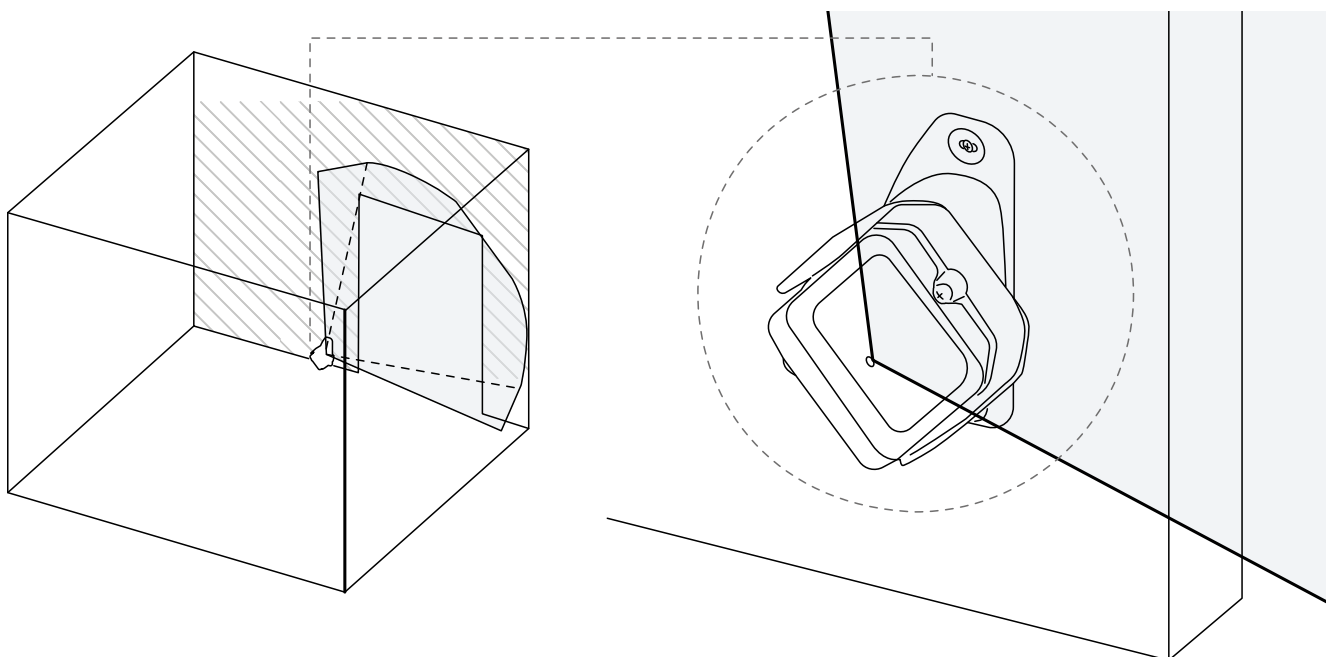

Wall installation (for example for access control of an entrance).

**Note:** install the sensor so that the field of view is tilted towards the outside of the hazardous area to avoid false alarms (see "Position of the field of view" on page 55).

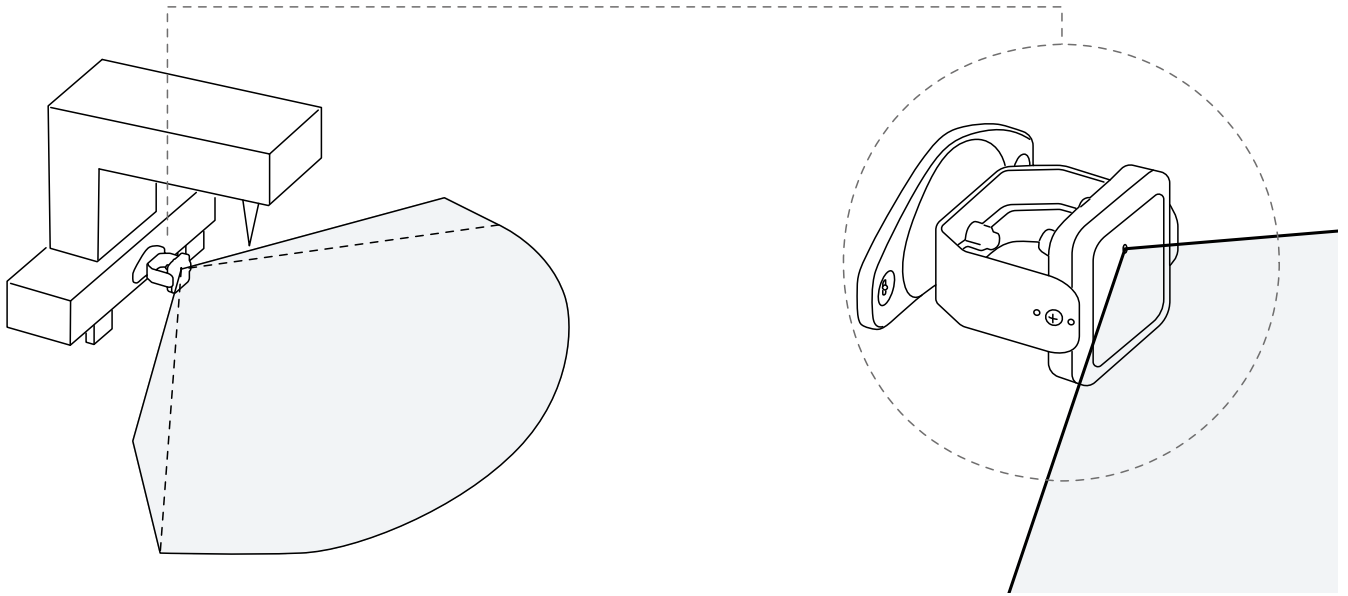

*Installation on the machinery.*

## 8.2.6 Connect the sensors to the control unit

**Note:** the total maximum length of the CAN bus line is 100 m (328.1 ft).

**Note:** when replacing a sensor, in the Inxpect Safety application, click **APPLY CHANGES** to confirm the change.

1. With the cable validator tool (downloadable from the site <https://tools.inxpect.com>), decide if the control unit will be positioned at the end of the chain or inside it (see "Chain examples" below).
2. Set the DIP switch of the control unit based on its position in the chain.
3. Connect the desired sensor directly to the control unit.
4. To connect another sensor, connect it to the last sensor in the chain or directly to the control unit to start a second chain.
5. Repeat step 4 for all the sensors to be installed.
6. Insert the bus terminator (product code: 07000003), into the free connector of the last sensor of the chain(s).

## 8.2.7 Chain examples

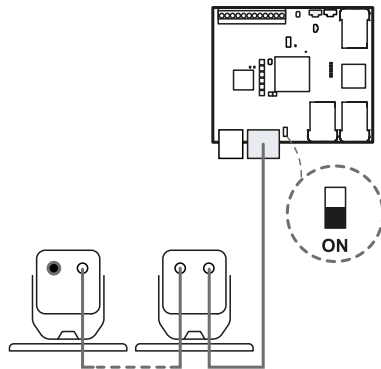

*Chain with control unit at the end of the chain and a sensor with bus terminator*

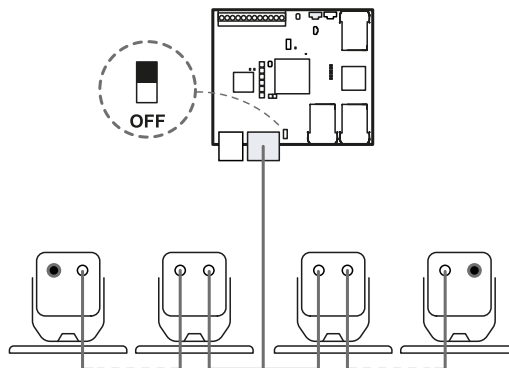

*Chain with control unit inside the chain and two sensors with bus terminator*



## 8.3 Set the sensor inclination with a 1° precision

### 8.3.1 Procedure

1. Remove the tamper-proof screws and remove the sensor from the bracket.

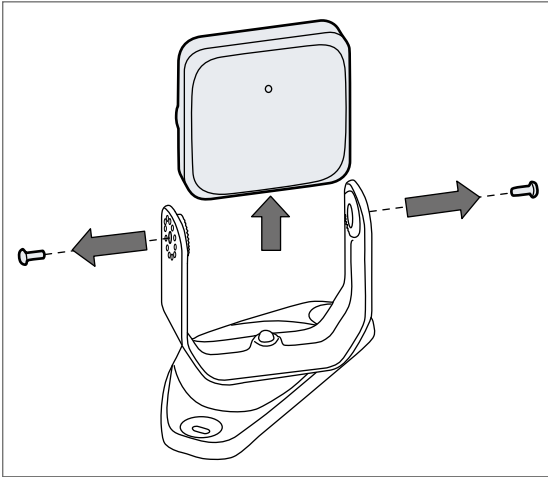

2. Remove the internal adjustment ring from the bracket.

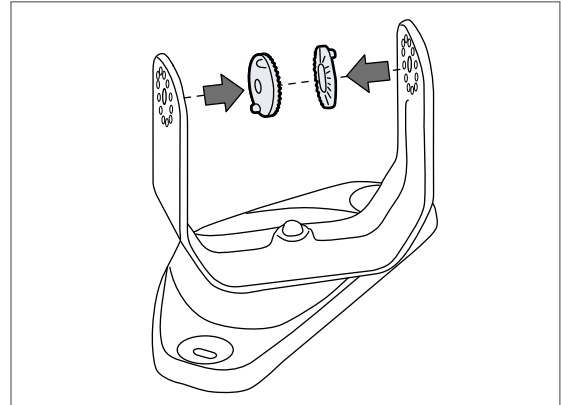

3. Reinsert the adjustment ring in the bracket holes according to the unit value of the desired inclination degrees (see "How to choose the adjustment ring position" on the next page).

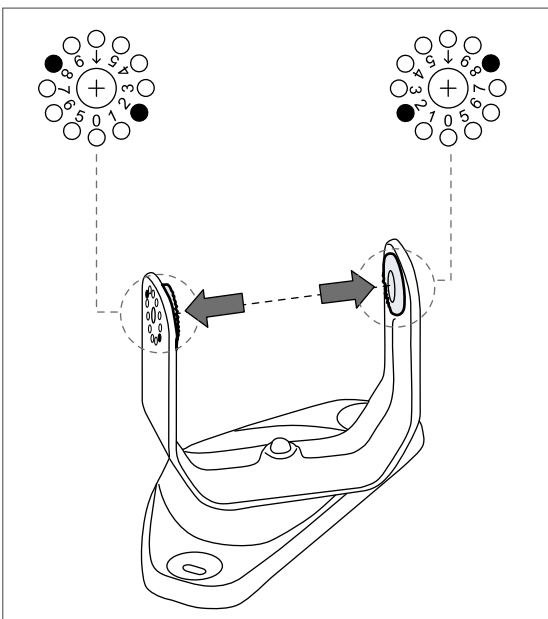

4. Insert the sensor and the tamper-proof screws in the bracket (see "How to insert the sensor" on the next page).

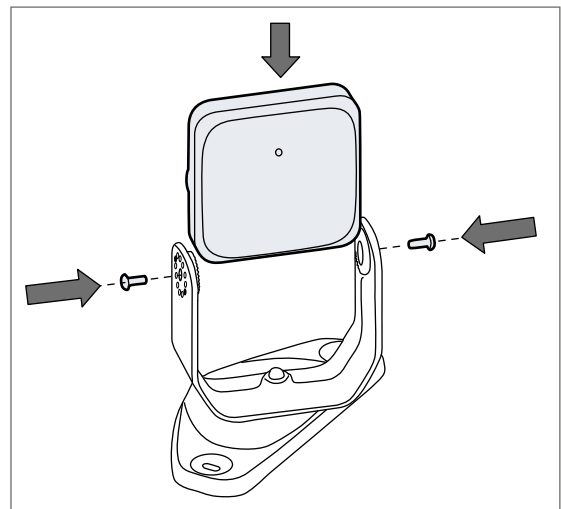

5. Tilt the sensor downward or upward the number of notches corresponding to the tens place value of the desired angle (for example, for an inclination angle of  $+38^\circ$ , the tens place value is 3: tilt the sensor upward three notches).

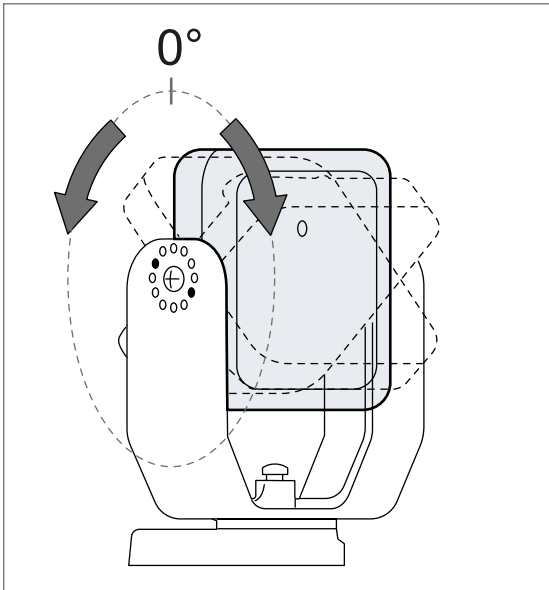

6. Tighten the screws.

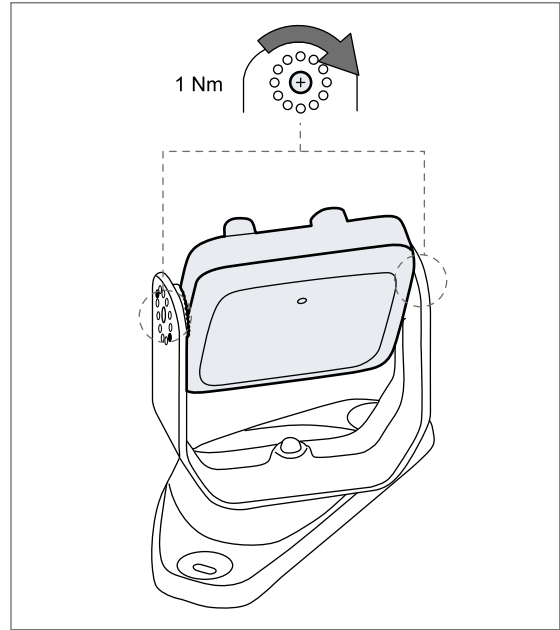

### 8.3.2 How to choose the adjustment ring position

On both sides of the bracket, insert the adjustment ring in the hole corresponding to the desired degree unit value (0-9°).

For example, for  $8^\circ$  (upward),  $+38^\circ$  (upward) and  $-18^\circ$  (downward) the unit value is always 8°:

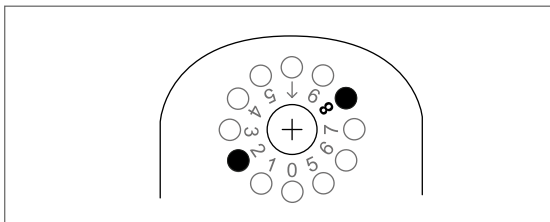

Side 1

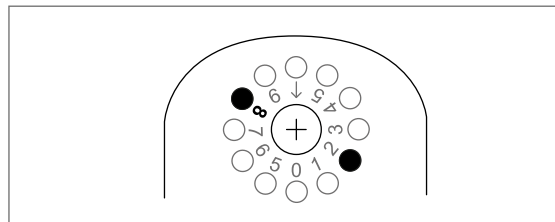

Side 2

### 8.3.3 How to insert the sensor

To insert the sensor in the bracket, take into account the following rules:

To tilt the sensor...	...then insert the sensor as follows	See
upward	with the <b>rear</b> of the case facing the desired angle	"Example 1 (upward): $+62^\circ$ " below
downward	with the <b>front</b> of the case facing the desired angle	"Example 2 (downward): $-37^\circ$ " on the next page

#### Example 1 (upward): $+62^\circ$

In this example, the rear of the case is facing the following angles:  $1^\circ$ ,  $2^\circ$ ,  $3^\circ$ ,  $4^\circ$ ,  $5^\circ$ .

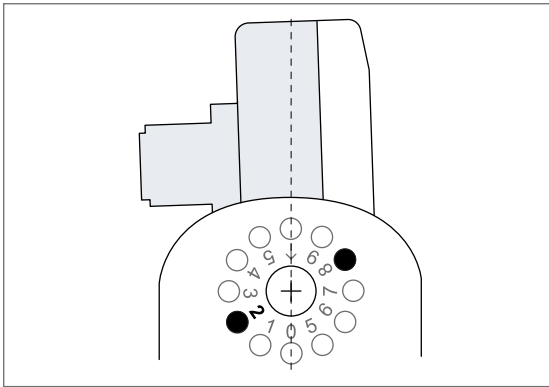

Side 1

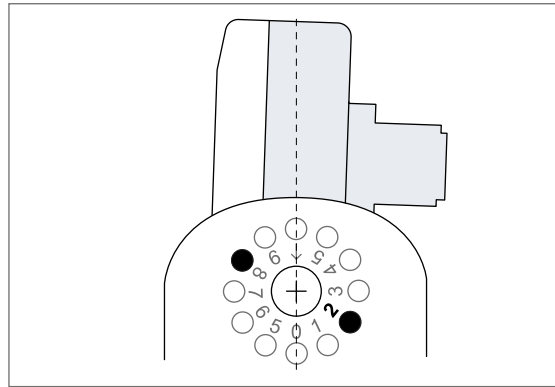

Side 2

**Example 2 (downward): -37°**

In this example, the front of the case is facing the following angles: 5°, 6°, 7°, 8°, 9°.

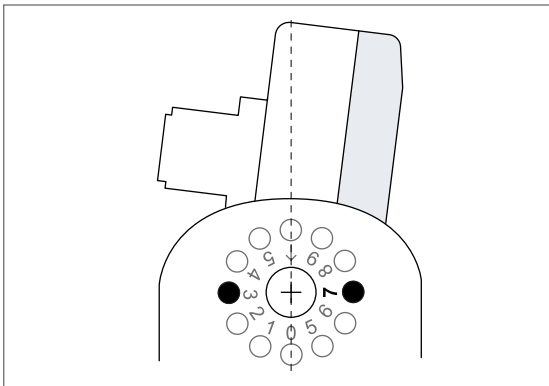

Side 1

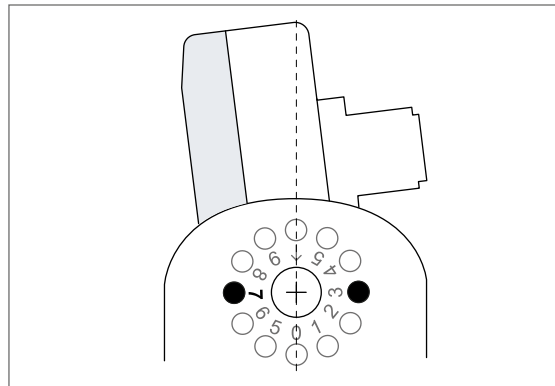

Side 2

### 8.3.4 Example: set the sensor inclination to +62°

1. Insert the adjustment ring in the hole corresponding to 2°.

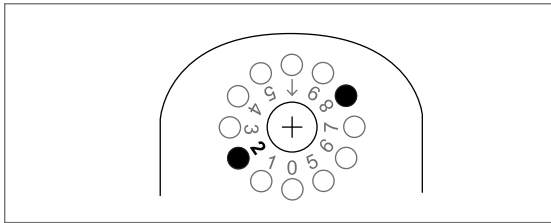

Side 1

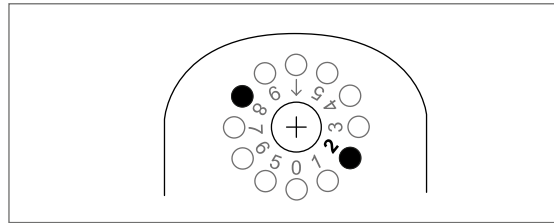

Side 2

2. Insert the sensor in the bracket with the rear of the sensor facing the 2° angle.

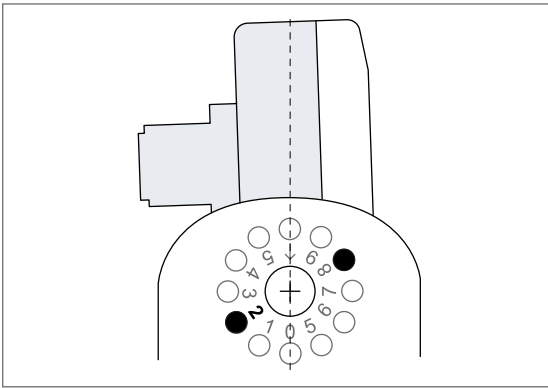

3. Tilt the sensor upward of six notches.

## 8.4 Configure Inxpect SRE 200 Series

### 8.4.1 Configure procedure

1. "Start the Inxpect Safety application".
2. "Define the area to be monitored".
3. "Configure the inputs and outputs".
4. "Save and print the configuration".
5. Optional. "Assign the Node IDs".
6. Optional. "Synchronize the control units".

### 8.4.2 Start the Inxpect Safety application

1. Connect the control unit to the computer using a data USB cable with a micro-USB connector or the Ethernet cable (if an Ethernet port is available).
2. Supply power to the control unit.
3. Start the Inxpect Safety application.
4. Choose the connection mode (USB or Ethernet).

**Note:** the default IP address for the Ethernet connection is 192.168.0.20. The computer and the control unit must be connected to the same network.

5. Set a new admin password, memorize it, and provide it only to authorized people.
6. Select the system Inxpect SRE 200 Series, the sensor model-type (5 meters range sensors or 9 meters range sensors), and the number of sensors.
7. Optional. Reset and re-assign all Node IDs.
8. Set the country in which the system is installed.

**Note:** this setting does not have any effect on system performance or safety. The country selection is requested during the first installation of the system to configure the system's radio profile, which must comply with the national regulations of the installation country.

9. Select the application type.

**Note:** the algorithms are optimized to minimize the interference between sensors based on the installation conditions. Even though this choice does not affect the performance and the robustness, it is mandatory to select the correct application type.

**Note:** if the application type is set as **Stationary**, the system can manage only one dynamic configuration.

### 8.4.3 Define the area to be monitored



**WARNING!** The system is disabled during configuration. Prepare opportune safety measures in the dangerous area protected by the system before configuring the system.

1. In the Inxpect Safety application click **Configuration**.
2. Optional. Add the desired number of sensors in the plane.
3. Define the position and inclination of each sensor.
4. Choose the area shape (only for 5.x sensors).
5. If necessary, set a **RCS Threshold** value higher than 0 dB to use the Custom target detection instead of the Human detection. To choose the value, click **RCS Reader Tool** to open the RCS Reader Tool. Refer to the RCS Reader Tool instructions for more information on how to use this tool.
6. Define the safety working mode, detection distance, angular coverage, and restart timeout for each detection field of each sensor.
7. Optional. Enable the **Static object detection** option for each detection field only if needed. For details, see "Restart prevention function: static object detection option" on page 45.

### 8.4.4 Configure the inputs and outputs

1. In the Inxpect Safety application, click **Settings**.
2. Click **Digital Input-Output** and define the input and output functions.
3. If the muting is managed, click **Settings > Muting** and assign the sensors to the groups according to the logic of the digital inputs.
4. **Settings > Restart function** and choose the type of managed restart.
5. Click **APPLY CHANGES** to save the configuration.

### 8.4.5 Save and print the configuration

1. In the application, click **APPLY CHANGES**: the sensors will save the inclination set and the surrounding environment. The application will transfer the configuration to the control unit, and once transfer is complete it will generate a configuration report.
2. Click  to save and print the report.  
**Note:** to save the PDF, a printer must be installed on the computer.
3. Ask the authorized person for a signature.

### 8.4.6 Assign the Node IDs

#### Type of assignment

**Note:** if the connected sensors do not already have a Node ID assigned (e.g., at first startup), the system automatically assigns them a Node ID during the installation procedure.

Three types of assignment are possible:

- Manual: to assign the Node ID to a sensor at a time. Can be performed with all the sensors already connected or after each connection. Useful for adding a sensor or to change Node ID to a sensor.
- Automatic: to assign the Node IDs to all the sensors at once. To be performed when all the sensors are connected.

**Note:** the control unit assigns the Node ID in ascending order of sensor ID (SID).

- Semi-automatic: wizard for connecting the sensors and assign the Node ID one sensor at a time.

#### Procedure

1. Start the application.
2. Click **Configuration** and verify that the number of sensors in the configuration is the same as those installed.

3. Click **Settings > Node ID Assignment**.
4. Proceed according to the type of assignment:

If the assignment is...	Then...
manual	<ol style="list-style-type: none"> <li>1. Click <b>DISCOVER CONNECTED SENSORS</b> to display the connected sensors.</li> <li>2. To assign a Node ID, click <b>Assign</b> for the unassigned Node ID in the <b>Configured sensors</b> list.</li> <li>3. To change a Node ID, click <b>Change</b> for the already assigned Node ID in the <b>Configured sensors</b> list.</li> <li>4. Select the SID of the sensor and confirm.</li> </ol>
automatic	<ol style="list-style-type: none"> <li>1. Click <b>DISCOVER CONNECTED SENSORS</b> to display the connected sensors.</li> <li>2. Click <b>ASSIGN NODE IDS &gt; Automatic</b>: the control unit assigns the Node ID in ascending order of sensor ID (SID).</li> </ol>
semi-automatic	Click <b>ASSIGN NODE IDS &gt; Semi-automatic</b> and follow the instructions displayed.

### 8.4.7 Synchronize the control units

If there is more than one control unit in the area, perform the following steps:

1. In the Inxpect Safety application, click **Settings > Advanced**.
2. In **Multi-control unit synchronization**, assign a different **Control unit channel** to each control unit.

*Note: if there are more than four control units, the control units with the same channel must have their monitored areas as far from each other as possible.*

## 8.5 Validate the safety functions

### 8.5.1 Validation

The validation is addressed to the machinery manufacturer and the system installer.

Once the system has been installed and configured, check that the safety functions are activated/deactivated as expected and that the dangerous area is monitored by the system.

The machinery manufacturer must define all the required tests based on the application conditions and the risk assessment.



**WARNING! The system response time is not guaranteed during the validation procedure.**



**WARNING! The Inxpect Safety application facilitates the installation and configuration of the system. Nevertheless, the validation process described below is still required to complete the installation.**

### 8.5.2 Validation procedure for the access detection function

The access detection safety function must be operative, and the following requirements must be fulfilled:

- If the Custom target detection safety function is not enabled, the target should be a human.
- If the Custom target detection safety function is enabled, the target should be chosen according to the smallest object to be detected.
- The target (for stationary applications) or the machinery/vehicle on which the sensor is installed (for mobile applications) must move in compliance with the maximum allowed speed (see "Access detection speed limits" on page 42 for details).
- No objects should completely occlude the target.

#### Starting conditions

- Machinery switched off (Safe condition)
- Inxpect SRE 200 Series configured to fulfill the access detection safety function
- Detection signals monitored via digital outputs or safety Fieldbus (i.e., PROFIsafe or FSoE)

#### Test setup

The following tests aim to validate the sensor's performance for the access detection safety function

In stationary applications, all the tests share these parameters:

<b>Target type</b>	Either human (if the Custom target detection safety function is disabled) or the smallest object to be detected (if the Custom Target Detection safety function is enabled)
<b>Target speed</b>	In the range [0.1, 1.6] m/s ([0.33, 5.25] ft/s), with particular attention to the minimum and the maximum speeds.
<b>Acceptance criteria</b>	The system reaches the safe state via digital outputs or Fieldbus when the target accesses the area during the test.

In mobile applications, all the tests share these parameters:

<b>Target type</b>	Either human (if the Custom target detection safety function is disabled) or the smallest object to be detected (if the Custom Target Detection safety function is enabled)
<b>Machinery/Vehicle speed</b>	In the range [0.1, 4] m/s ([0.33, 13.12] ft/s), with particular attention to the minimum and the maximum speeds.
<b>Target movement</b>	Stationary
<b>Acceptance criteria</b>	The system reaches the safe state via digital outputs or Fieldbus when, during the movement of the machinery/vehicle, the sensor's field of view reaches the target.

### Validation test

The validation procedure of Inxpect SRE 200 Series is reported below:

1. Identify the test positions, including those locations where the operator could access during the production cycle:
  - a. boundaries of the dangerous area
  - b. intermediate points between sensors
  - c. positions that are partially hidden by existing or presumed obstacles during the operating cycle
  - d. positions indicated by the risk assessor
2. Check that the corresponding detection signal is active or wait for its activation.
3. Perform the test according to the test setup previously defined, moving toward one of the test positions.
4. Check that the test acceptance criteria previously defined are fulfilled. If the test acceptance criteria are not fulfilled, see "Troubleshooting validation" on page 81
5. Repeat steps 2, 3, and 4 for each test position.

### 8.5.3 Validation procedure for the restart prevention function

The restart prevention safety function must be operative, and the following requirements must be fulfilled:

- The person must breathe normally.
- No objects should completely occlude the person.

#### Starting conditions

- Machinery switched off (safe condition)
- Inxpect SRE 200 Series configured to fulfill the restart prevention safety function
- Detection signals monitored via digital outputs or safety Fieldbus (i.e., PROFIsafe or FSoE)

#### Test setup

The following tests aim to validate the performance of the sensor restart prevention safety function.

All the tests share the following parameters:

<b>Configured radar restart timeout</b>	At least 4 s
<b>Target type</b>	Human according to ISO 7250, breathing normally
<b>Target speed</b>	0 m/s (0 ft/s)
<b>Target pose</b>	Standing or crouching (or other poses if requested by specific risk assessment)
<b>Test duration</b>	At least 20 s
<b>Acceptance criteria</b>	The detection signal remains deactivated during the test. When the operator leaves the area; the detection signal is activated.

### Validation test

The validation procedure of the Inxpect SRE 200 Series system is reported below:

1. Identify the test positions, including those locations where the operator should normally be located during the production cycle:
  - boundaries of the dangerous area
  - intermediate points between sensors
  - positions that are partially hidden by already present or presumed obstacles during the operating cycle
  - positions indicated by the risk assessor
2. Access the dangerous area and go to one of the test positions: the corresponding detection signal should be deactivated.
3. Perform the test according to the test setup previously defined.
4. Check that the test acceptance criteria previously defined are fulfilled.
5. If the test acceptance criteria are not fulfilled, see "Validate the system with Inxpect Safety" on the next page
6. Repeat steps 2, 3, and 4 for each test position.

### Example of test positions

The following images show examples of positions to be tested and suggestions about identifying other possible positions of interest.

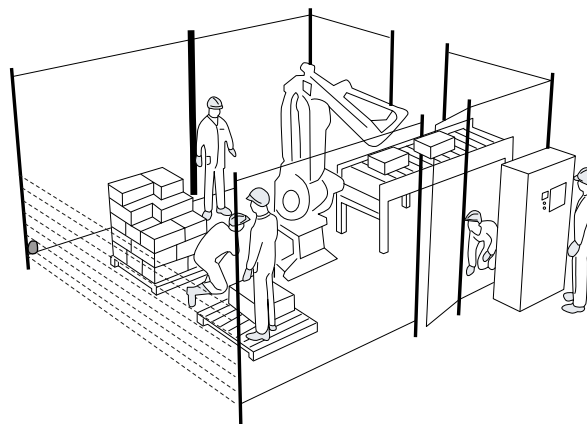
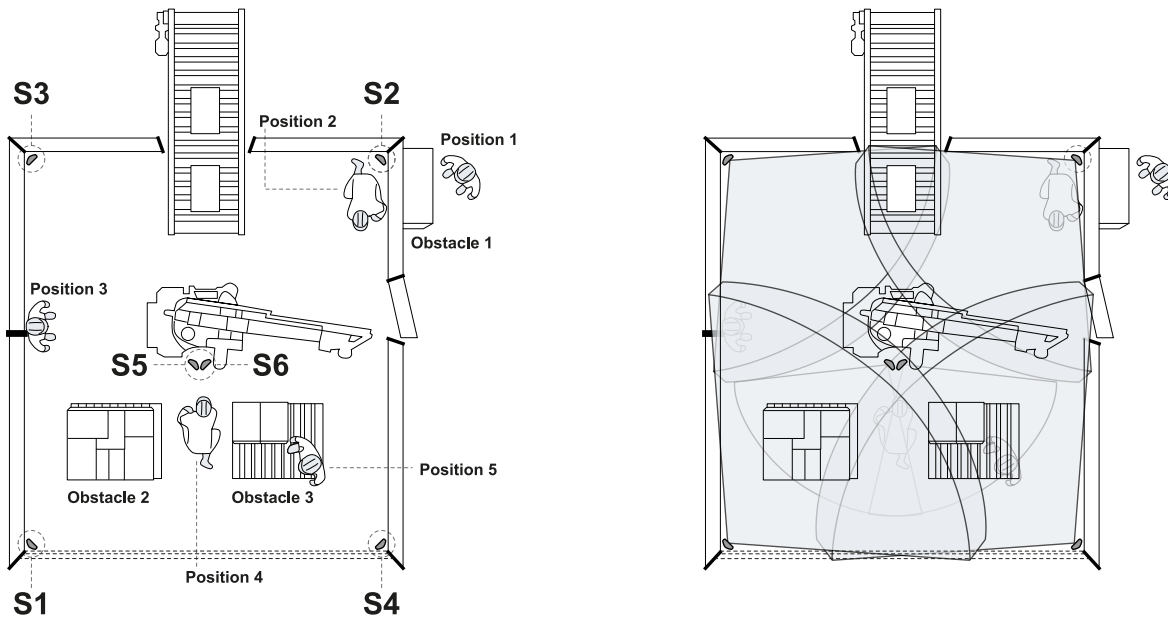

**Position 1:** position outside the dangerous area

**Position 2:** position hidden from the operator’s viewpoint at “Position 1”. Any other similar hidden position should be tested.



**Position 3:** position at the center distance between two sensors and/or close to the boundaries of the dangerous area (e.g., along safety fences). This position is suggested to verify that the detection fields of different sensors overlap without leaving uncovered areas. Standing close to the fences also allows for verifying that the sensors are rotated correctly, covering both the right and the left side.

**Position 4:** possible hidden position by elements in the environment that are present or not present during the validation process. Examples: Obstacle 2 precludes detection by Sensor 1 (**S1**). Obstacle 3 is partially present during the Validation process but will likely be present during the normal operating cycle and will preclude the detection of Sensor 4 (**S4**). This position must be covered by additional Sensor 5 (**S5**) and Sensor 6 (**S6**) that should be added within a proper feasibility study.

**Position 5:** any raised and walkable position indicated by the risk assessor.

Other positions can be indicated by the risk assessor or the machine manufacturer.

## 8.5.4 Validate the system with Inxpect Safety



**WARNING! When the validation function is active, the system response time is not guaranteed.**

The Inxpect Safety application is helpful during the safety functions validation phase and allows the actual field of view of the sensors to be checked based on their installation position.

1. Click **Validation**: the validation starts automatically.
2. Move in the monitored area as indicated in "Validation test" on the previous page and "Validation procedure for the restart prevention function" on page 79.
3. Check that the sensor behaves as expected.

**Note:** if the static object detection option is enabled, the empty dot represents a moving target, and the full dot represents a static target.

4. Check that the distance and the angle where the motion is detected are the expected values.

## 8.5.5 Troubleshooting validation

Problem	Cause	Solution
The detection signal does not remain deactivated during the restart prevention test, or it does not deactivate during the access detection test	Presence of objects obstructing the field of view	If possible, remove the object. Otherwise, implement additional safety measures in the area where the object is present (e.g., adding new sensors).
	Position of one or more sensors	Position the sensors to ensure that the monitored area is adequate for the dangerous area (see "Sensor position" on page 53).
	Inclination and/or installation height of one or more sensors	<ol style="list-style-type: none"> <li>1. Change the sensor's inclination and/or installation height to ensure the monitored area is adequate for the dangerous area (see "Sensor position" on page 53).</li> <li>2. Note or update the inclination and installation height of the sensors in the printed configuration report.</li> </ol>
	Inadequate restart timeout (only with the static object detection option enabled)	Change the <b>Restart timeout</b> parameter through the Inxpect Safety application and verify that it is set to at least 4 seconds for each sensor ( <b>Configuration</b> > select the affected sensor and detection field)
After that the operator leaves the area, the detection signal does not activate	Presence of moving objects in the sensor's field of view (including vibrations of metal parts where the sensors are installed or vibration of brackets)	Identify the moving objects/brackets and, if possible, tighten all the loose parts
	Reflections of signals	Change the sensor positions or adjust the detection fields reducing the detection distance

## 8.6 Manage the configuration

### 8.6.1 Configuration checksums

In the Inxpect Safety application in **Settings > Configuration checksums**, it is possible to consult:

- the configuration report hash, a unique alphanumeric code associated with a report. It is computed considering the entire configuration, plus the time of the **APPLY CHANGES** operation, and the name of the computer which did it
- dynamic configuration checksum, associated with a specific dynamic configuration. It considers both common and dynamic parameters

### 8.6.2 Configuration reports

After changing the configuration, the system generates a configuration report with the following information:

- configuration data
- unique hash
- date and time of configuration change
- name of the computer used for the configuration

The reports are documents that cannot be changed and can only be printed and signed by the machinery safety manager.

**Note:** to save the PDF, a printer must be installed on the computer.

### 8.6.3 Change the configuration



**WARNING! The system is disabled during configuration. Prepare opportune safety measures in the dangerous area protected by the system before configuring the system.**

1. Start the Inxpect Safety application.
2. Click **User** and enter the admin password.  
**Note:** after five wrong password entries, application authentication is blocked for one minute.
3. Depending on what you want to change, follow the instructions below:

To change...	Then...
Monitored area and sensors configuration	Click <b>Configuration</b>
Node ID	Click <b>Settings &gt; Node ID Assignment</b>
Function of inputs and outputs	Click <b>Settings &gt; Digital Input-Output</b>
Detection field groups configuration	Click <b>Settings &gt; Detection field groups</b> and select the group for each detection field of each connected sensor. Then click <b>Settings &gt; Digital Input-Output</b> and set a digital output as <b>Detection signal group 1</b> or <b>Detection signal group 2</b> function
Muting	Click <b>Settings &gt; Muting</b>
Sensor number and positioning	Click <b>Configuration</b>

4. Click **APPLY CHANGES**.
5. Upon conclusion of transfer of the configuration to the control unit, click  to print the report.  
**Note:** to save the PDF, a printer must be installed on the computer.

### 8.6.4 Display previous configurations

In **Settings**, click **Activity History** and then click **Configuration reports page**: the reports archive opens.

## 8.7 Other procedures

### 8.7.1 Change language

1. Click .
2. Select the desired language. The language changes automatically.

### 8.7.2 Restore factory default settings



**WARNING!** The system is provided without any valid configuration. Therefore the system maintains the safe state at the first start-up until a valid configuration is applied through the Inxpect Safety application by clicking **APPLY CHANGES**.



**WARNING!** The procedure resets both the configuration and the password of all the users.

To restore the configuration parameters to the default settings, follow the procedures reported below:

#### Procedure using the Inxpect Safety application

1. Log in to the Inxpect Safety application as the Admin user.
2. In **Admin > FACTORY RESET**.

#### Procedure using the reset button on the control unit

1. Press and hold the button **[A]** for longer than 10 seconds: all the system status LEDs **[B]** turn on (steady orange), and the system is ready to be reset.
2. Release the button **[A]**: all the system status LEDs **[B]** turn on (flashing green), and the reset procedure starts. The procedure can last up to 30 seconds. Do not switch off the system during the reset.

**Note:** if the button is pressed for longer than 30 seconds, the status of the LEDs switches to red, and the reset is not performed even after the button is released.

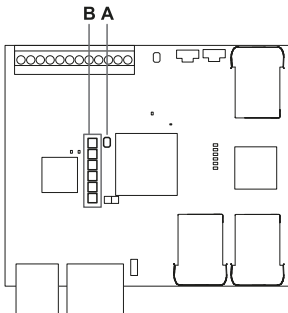

For the default values of the parameters, see "Configuration application parameters" on page 115.

### 8.7.3 Reset the control unit Ethernet parameters

1. Ensure the control unit is turned on.
2. Press the Network parameter reset button and hold it down during steps 3 and 4.
3. Wait for five seconds.
4. Wait until all the six LEDs on the control unit turns steady green: the Ethernet parameters are set to their default values (see "Ethernet connection (if available)" on page 103).
5. Configure the control unit again.

### 8.7.4 Restore network parameters



**WARNING!** After the restore network parameters procedure, the system goes into the safe state. The configuration must be validated and, if necessary, modified through the Inxpect Safety application by clicking **APPLY CHANGES**.

1. To restore the network parameters to the default settings, press and hold the reset button **[A]** on the control unit for 2 to 5 seconds: the first three system status LEDs **[B]** turn on (steady orange) and the network parameters are ready to be reset.
2. Release the button **[A]**: the reset is performed.

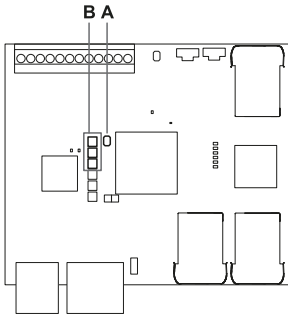

For the default values of the parameters, see "Configuration application parameters" on page 115.

### 8.7.5 Identify a sensor

In **Settings > Node ID Assignment** or **Configuration**, click **Identify by LED** near the desired sensor Node ID: the LED on the sensor flashes for 5 seconds.

### 8.7.6 Change network parameters

In **Admin > Network Parameters** change the IP address, the netmask and the gateway of the control unit as desired.

### 8.7.7 Change MODBUS parameters

In **Admin > MODBUS Parameters**, enable/disable the MODBUS communication and modify the listening port.

### 8.7.8 Change Fieldbus parameters

In **Admin > Fieldbus Parameters**, change the F-addresses and the Fieldbus Endianness of the control unit if the control unit is provided with a PROFIsafe interface; or the Safe Address if it is provided with a Safety over EtherCAT® interface.

### 8.7.9 Set system labels

In **Admin > System labels**, choose the desired labels for the control unit and the sensors.

# 9. Troubleshooting

## Machinery maintenance technician

The machinery maintenance technician is a qualified person with the administrator privileges required to modify the configuration of Inxpect SRE 200 Series through the software and perform maintenance and troubleshooting.

### Contents

This section includes the following topics:

<b>9.1 Troubleshooting procedures</b> .....	<b>85</b>
<b>9.2 Event log management</b> .....	<b>88</b>
<b>9.3 INFO events</b> .....	<b>92</b>
<b>9.4 ERROR events (control unit)</b> .....	<b>94</b>
<b>9.5 ERROR events (sensor)</b> .....	<b>96</b>
<b>9.6 ERROR events (CAN bus)</b> .....	<b>98</b>

## 9.1 Troubleshooting procedures

**Note:** if requested by Technical Support, in **Settings > Activity History**, click **Download sensor debug info** to download the files and forward them to Inxpect for debugging.

### 9.1.1 Control unit LED

For more details about the LEDs in the control unit, see "Control units" on page 17 and "System status LEDs" on page 20.

LED	Status	Inxpect Safety application messages	Problem	Solution
S1*	Steady red	CONTROL UNIT POWER ERROR	At least one voltage value on the control unit is wrong	If at least one digital input is connected, check that the SNS input and the GND input are connected.  Check that the input power supply is the specified type (see "General specifications" on page 103).
S1 + S3	Steady red	BACKUP or RESTORE ERROR	Error during the backup and restore to/from microSD card	Check if the microSD card is inserted.  Check if the configuration file on the microSD card is present and not corrupted.
S2	Steady red	CONTROL UNIT TEMPERATURE ERROR	Control unit temperature value is wrong	Check that the system is operating at the correct operating temperature (see "General specifications" on page 103).
S3	Steady red	OSSD ERROR or INPUT REDUNDANCY ERROR	At least one input or output is in error	If at least one input is used, check that both the channels are connected and that there is no short-circuit on the outputs.  If the problem persists, please contact Technical Support.
S4	Steady red	PERIPHERAL ERROR	At least one of the control unit peripherals is in error	Check the status of the terminal block and connections.  If the problem persists, please contact Technical Support.

LED	Status	Inxpect Safety application messages	Problem	Solution
S5	Steady red	CAN ERROR	Communication error with at least one sensor	<p>Check connections of all sensors in the chain starting from the last sensor in error.</p> <p>Check that all the sensors have an assigned ID (in Inxpect Safety <b>Settings &gt; Node ID Assignment</b>).</p> <p>Check that the firmware of the control unit and sensors are updated to the compatible versions.</p>
S6	Steady red	FEE ERROR, FLASH ERROR or RAM ERROR	Configuration saving error, configuration not performed or memory error	<p>Reconfigure or configure the system (see "Manage the configuration" on page 82).</p> <p>If the error persists, please contact Technical Support.</p>
All LEDs from S1 to S6 together	Steady red	FIELDBUS ERROR	Communication error on the Fieldbus	<p>At least one input or output is configured as <b>Fieldbus controlled</b>.</p> <p>Check that the cable is correctly connected, communication with the host is correctly established, watchdog timeout is configured correctly, and exchanged data are not maintained passivated.</p>
All LEDs from S1 to S5 together	Steady red	DYNAMIC CONFIGURATION ERROR	Error in the selection of the dynamic configuration: invalid ID	Check the preset configurations within the Inxpect Safety application.
All LEDs from S1 to S4 together	Steady red	SENSOR CONFIGURATION ERROR	Error during the configuration of the sensors	<p>Check the sensors connected and try again to perform the configuration of the system via the Inxpect Safety application.</p> <p>Check that the firmware of the control unit and sensors are updated to compatible versions.</p>
At least one LED	Flashing red	See "Sensor LED" on the next page	Sensor corresponding to the flashing LED in error ** (see "Sensor LED" on the next page)	Check the problem through the LED on the sensor.
At least one LED	Flashing green	See "Sensor LED" on the next page	Sensor corresponding to the flashing LED in error ** (see "Sensor LED" on the next page)	If the issue persists longer than one minute, please contact Technical Support.
All LEDs	Steady orange	-	The system is starting up.	Wait for a few seconds.
All LEDs	Flashing green one after the other in sequence	-	The control unit is in boot state.	<p>Open the latest available version of the Inxpect Safety application, connect to the device and proceed with the automatic recovery procedure.</p> <p>If the issue persists, please contact Technical Support.</p>
All LEDs	Off	In <b>Dashboard &gt; System status</b>  icons	Configuration not yet applied to the control unit.	Configure the system.
All LEDs	Off	Progress icon	Configuration transfer to the control unit in progress.	Wait for the transfer to be completed.

**Note:** fault signal on the control unit (steady LED) takes priority over a faulty sensor signal. For the status of the single sensor, check the sensor LED.

**Note\*:** S1 is the first from the top.

**Note\*\*:** S1 corresponds to the sensor with ID 1, S2 corresponds to the sensor with ID 2 and so on.



## 9.1.2 Sensor LED

Status	Inxpect Safety application messages	Problem	Solution
Steady purple	-	Sensor in boot state	Contact Technical Support.
Flashing purple *	-	Sensor receiving a firmware update	Wait for the update to be completed without disconnecting the sensor.
Flashing red. Two flashes followed by a pause **	CAN ERROR	Sensor without a valid identifier assigned	Assign a Node ID to the sensor (see "Connect the sensors to the control unit" on page 72).
Flashing red. Three flashes followed by a pause **	CAN ERROR	Sensor does not receive valid messages from the control unit	Verify the connection of all the sensors in the chain and check that the number of sensors configured in the Inxpect Safety application is equal to the number of the sensors physically connected
Flashing red. Four flashes followed by a pause **	SENSOR TEMPERATURE ERROR or SENSOR POWER ERROR	Sensor in temperature error or is receiving an incorrect supply voltage	Check the sensor connection and that the cable length is within the maximum limits. Verify that the temperature of the environment in which the system is operating conforms to the operating temperatures listed in the technical data in this manual.
Flashing red. Five flashes followed by a pause **	MASKING, SIGNAL PATTERN ERROR	Sensor detected a masking (tampering) or there are radar signal errors	Not available if the sensor is in muting. Check that the sensor is installed correctly and that the area is clear of objects that obstruct the sensor's field of view.
	MASKING REFERENCE MISSING	Sensor is not able to save the monitored area reference for occlusion	Repeat the system configuration making sure no movement is present inside the monitored area
	MSS ERROR/DSS ERROR	Error detected by diagnostics relative to the internal micro-controllers (MSS and DSS), their internal peripherals or memories	If the issue persists, please contact Technical Support.
Flashing red. Six flashes followed by a pause **	TAMPER ERROR	Sensor detected a variation in rotation around the axes (tampering)	Not available if the sensor is in muting. Check if the sensor has been tampered with or if the side or mounting screws have loosened.

**Note \*:** flashes at 100 ms intervals without pause

**Note \*\*:** flashes at 200 ms intervals and then with a 2 s pause.

### 9.1.3 Other problems

Problem	Cause	Solution
Undesired detections	Transit of people or objects in close proximity to the detection field	Change the configuration (see "Change the configuration" on page 82).
Machinery in safe status without motion in the detection field	No power supply	Check electrical connection. Contact Technical Support if necessary.
	Failure of the control unit or one or more sensors	Check the status of the LEDs on the control unit (see "Control unit LED" on page 85). Access the application Inxpect Safety, on the <b>Dashboard</b> page, mouse-over on  in correspondence with the control unit or the sensor.
The voltage value detected on the SNS input is zero	The chip that detects inputs is faulty	Contact Technical Support.
The system does not function correctly	Control unit error	Check the status of the LEDs on the control unit (see "Control unit LED" on page 85). Access the application Inxpect Safety, on the <b>Dashboard</b> page, mouse-over on  in correspondence with the control unit or the sensor.
	Sensor error	Check the status of the LEDs on the sensor (see "Sensor LED" on the previous page). Access the application Inxpect Safety, on the <b>Dashboard</b> page, mouse-over on  in correspondence with the control unit or the sensor.

## 9.2 Event log management

### 9.2.1 Introduction

The event log recorded by the system can be downloaded from the Inxpect Safety application in a PDF file. The system saves up to 4500 events, divided in two sections. In each section the events are displayed from the most recent to the least recent. Above this limit, the oldest events are overwritten.

### 9.2.2 Download the system log



**WARNING!** The system response time is not guaranteed while downloading the log file.

1. Start the Inxpect Safety application.
2. Click **Settings** and then **Activity History**.
3. Click **DOWNLOAD LOG**.

**Note:** to save the PDF, a printer must be installed on the computer.

### 9.2.3 Log file sections

The first line of the file reports the NID (Network ID) of the device and the date of the download.

The rest of the file log is divided in two sections:

Section	Description	Content	Size	Reset
1	Event log	Information events Error events	3500	At every firmware update or on demand using the Inxpect Safety application
2	Diagnostic event log	Error events	1000	Not possible



## 9.2.4 Log line structure

Each line in the log file reports the following information, separated by tab character:

- Timestamp (seconds counter from the latest boot)
- Timestamp (absolute/relative value)
- Event type:
  - [ERROR]= diagnostic event
  - [INFO]= information event
- Source
  - CONTROL UNIT = if the event is generated by the control unit
  - SENSOR ID = if the event is generated by a sensor. In this case, the Node ID of the sensor is also provided
- Event description

## 9.2.5 Timestamp (seconds counter from the latest boot)

An indication of the instant when the event occurred is provided as relative time from the latest boot, in seconds.

Example: 92

Meaning: the event occurred 92 seconds after the latest boot

## 9.2.6 Timestamp (absolute/relative value)

An indication of the instant when the event occurred is provided.

- After a new system configuration, it is provided as absolute time.

Format: YYYY/MM/DD hh:mm:ss

Example: 2020/06/05 23:53:44

- After a reboot of the device, it is provided as relative time from the latest boot.

Format: Rel. x d hh:mm:ss

Example: Rel. 0 d 00:01:32

**Note:** when a new system configuration is performed, even the older timestamps are updated in absolute time format.

**Note:** during system configuration, the control unit is receiving the local time of the machine where the software is running.

## 9.2.7 Event description

A complete description of the event is reported. Whenever possible, depending on the event, additional parameters are reported.

In case of a diagnostic event, an internal error code is also added, useful for the purpose of debug. If the diagnostic event disappears, the label “(Disappearing)” is reported as an additional parameter.

### Examples

Detection access (field #3, 1300 mm/40°)

System configuration #15

CAN ERROR (Code: 0x0010)      COMMUNICATION LOST

CAN ERROR (Disappearing)

## 9.2.8 Log file example

Event logs of ISC NID UP304 updated 2020/11/18 16:59:56

[Section 1 - Event logs]

```

380 2020/11/18 16:53:49 [ERROR] SENSOR#1 CAN ERROR (Disappearing)
375 2020/11/18 16:53:44 [ERROR] SENSOR#1 CAN ERROR (Code: 0x0010) COMMUNICATION LOST
356 2020/11/18 16:53:25 [INFO] CONTROL UNIT System configuration #16
30 2020/11/18 16:53:52 [ERROR] SENSOR#1 ACCELEROMETER ERROR (Disappearing)
27 2020/11/18 16:47:56 [ERROR] SENSOR#1 ACCELEROMETER ERROR (Code: 0x0010) TILT ANGLE ERROR
5 2020/11/18 16:47:30 [ERROR] SENSOR#1 SIGNAL ERROR (Code: 0x0012) MASKING
0 2020/11/18 16:47:25 [INFO] CONTROL UNIT Dynamic configuration #1
0 2020/11/18 16:47:25 [INFO] CONTROL UNIT System Boot #60
92 Rel. 0 d 00:01:32 [INFO] CONTROL UNIT Detection exit (field #2)
90 Rel. 0 d 00:01:30 [INFO] CONTROL UNIT Detection exit (field #1)
70 Rel. 0 d 00:01:10 [INFO] SENSOR#1 Detection access (field #2, 3100 mm/20°)
61 Rel. 0 d 00:01:01 [INFO] SENSOR#1 Detection access (field #1, 1200 mm/30°)
0 Rel. 0 d 00:00:00 [INFO] CONTROL UNIT Dynamic configuration #1
0 0 d 00:00:00 [INFO] CONTROL UNIT System Boot #61

```

[Section 2 - Diagnostic events log]

```

380 Rel. 0 d 00:06:20 [ERROR] SENSOR #1 CAN ERROR (Disappearing)
375 Rel. 0 d 00:06:15 [ERROR] SENSOR #1 CAN ERROR (Code: 0x0010) COMMUNICATION LOST
356 Rel. 0 d 00:05:56 [INFO] CONTROL UNIT System configuration #16
30 Rel. 0 d 00:00:30 [ERROR] SENSOR #1 ACCELEROMETER ERROR (Disappearing)
27 Rel. 0 d 00:00:27 [ERROR] SENSOR #1 ACCELEROMETER ERROR (Code: 0x0012) TILT ANGLE ERROR
5 Rel. 0 d 00:00:05 [ERROR] SENSOR #1 SIGNAL ERROR (Code: 0x0014) MASKING

```

## 9.2.9 Event list

The event logs are listed below:

Event	Type
Diagnostic errors	ERROR
System Boot	INFO
System configuration	INFO
Factory reset	INFO
Stop signal	INFO
Restart signal	INFO
Detection access	INFO
Detection exit	INFO
Dynamic configuration in use	INFO
Muting status	INFO
Fieldbus connection	INFO

Event	Type
MODBUS connection	INFO
Session authentication	INFO
Validation	INFO
Log download	INFO

For further information about the events, see "INFO events" on the next page and "ERROR events (control unit)" on page 94.

## 9.2.10 Verbosity level

There are six verbosity levels for the log. The verbosity can be set during the configuration of the system via the Inxpect Safety application (**Settings > Activity History > Log verbosity level**).

Depending on the selected verbosity level, the events are logged in accordance to the following table:

Event	Level 0 (default)	Level 1	Level 2	Level 3	Level 4	Level 5
Diagnostic errors	x	x	x	x	x	x
System Boot	x	x	x	x	x	x
System configuration	x	x	x	x	x	x
Factory reset	x	x	x	x	x	x
Stop signal	x	x	x	x	x	x
Restart signal	x	x	x	x	x	x
Detection access	-	See "Verbosity level for detection access and exit events" below				
Detection exit	-	See "Verbosity level for detection access and exit events" below				
Dynamic configuration in use	-	-	-	-	x	x
Muting status	-	-	-	-	-	x

## 9.2.11 Verbosity level for detection access and exit events

Depending on the selected verbosity level, the detection access and exit events are logged as follows:

- LEVEL 0: no detection info is logged
- LEVEL 1: the events are logged at the control unit level, and the additional information is the detection distance (in mm) and the detection angle (in °) in detection access

Format:

*CONTROL UNIT Detection access (distance mm/azimuth°)*

*CONTROL UNIT Detection exit*

- LEVEL 2: the events are logged in a single field at the control unit level, and the additional information is: detection field, detection distance (in mm) and detection angle (in °) in access, and detection field at exit

Format:

*CONTROL UNIT Detection access (field #n, distance mm/azimuth°)*

*CONTROL UNIT Detection exit (field #n)*

- LEVEL 3 / LEVEL 4 / LEVEL 5 The events are logged:
  - in a single field at the control unit level, and the additional information is: detection field, detection distance (in mm) and detection angle (in °) in access, and detection field at exit
  - at the sensor level and the additional information read by the sensor is: detection distance (in mm) and detection angle (in °) in access, and detection field at exit

Format:

*CONTROL UNIT #k Detection access (field #n, distance mm/azimuth°)*

*SENSOR #k Detection access (distance mm/azimuth°)*

*CONTROL UNIT*    *Detection exit (field #n)*

*SENSOR #k*    *Detection exit*

## 9.3 INFO events

### 9.3.1 System Boot

Every time the system is powered up, the event is logged reporting the incremental count of the boot from the beginning of the life of the device.

Format: *System Boot #n*

Example:

```
0    2020/11/18 16:47:25    [INFO]    CONTROL UNIT    SYSTEM BOOT #60
```

### 9.3.2 System configuration

Every time the system is configured, the event is logged reporting the incremental count of the configuration from the beginning of the life of the device.

Format: *System configuration #3*

Example:

```
20   2020/11/18 16:47:25   [INFO]   CONTROL UNIT   System configuration #3
```

### 9.3.3 Factory reset

Every time a factory reset is required, the event is logged.

Format: *Factory reset*

Example:

```
20   2020/11/18 16:47:25   [INFO]   CONTROL UNIT   Factory reset
```

### 9.3.4 Stop signal

If configured, every change of the Stop Signal is logged as ACTIVATION or DEACTIVATION.

Format: *Stop signal ACTIVATION/DEACTIVATION*

Example:

```
20   2020/11/18 16:47:25   [INFO]   CONTROL UNIT   Stop signal    ACTIVATION
```

### 9.3.5 Restart signal

If configured, every time the system is waiting for the restart signal or the restart signal is received, the event is logged as WAITING or RECEIVED.

Format: *Restart signal WAITING/RECEIVED*

Example:

```
20   2020/11/18 16:47:25   [INFO]   CONTROL UNIT   Restart signal  RECEIVED
```

### 9.3.6 Detection access

Every time motion is detected, a detection access is logged with additional parameters depending on the selected verbosity level: the detection field number, the sensor which detected the motion, the detection distance (in mm) and the detection angle (°) (see "Verbosity level for detection access and exit events" on the previous page).

Format: *Detection access (field #n, distance mm/azimuth°)*

Example:

```
20 2020/11/18 16:47:25 [INFO] SENSOR #1 Detection access (field #1, 1200 mm/30°)
```

### 9.3.7 Detection exit

After at least one detection access event, a detection exit event related to the same field is logged when the detection signal returns to its default no-motion status.

Depending on the selected verbosity level additional parameters are logged: the detection field number, the sensor which detected the motion.

Format: *Detection exit (field #n)*

Example:

```
20 2020/11/18 16:47:25 [INFO] CONTROL UNIT Detection exit (field #1)
```

### 9.3.8 Dynamic configuration in use

At every change of the dynamic configuration, the new ID of the dynamic configuration selected is logged.

Format: *Dynamic configuration #1*

Example:

```
20 2020/11/18 16:47:25 [INFO] CONTROL UNIT Dynamic configuration #1
```

### 9.3.9 Muting status

Every change of the muting status of each sensor is logged as disabled or enabled.

**Note:** *the event indicates a change of the muting status of the system. It does not correspond to the muting request.*

Format: *Muting disabled/enabled*

Example:

```
20 2020/11/18 16:47:25 [INFO] SENSOR#1 Muting enabled
```

### 9.3.10 Fieldbus connection

The Fieldbus communication status is logged as CONNECTED, DISCONNECTED or FAULT.

Format: *Fieldbus connection CONNECTED/DISCONNECTED/FAULT*

Example:

```
20 2020/11/18 16:47:25 [INFO] CONTROL UNIT Fieldbus connection CONNECTED
```

### 9.3.11 MODBUS connection

The MODBUS communication status is logged as CONNECTED or DISCONNECTED.

Format: *MODBUS connection CONNECTED/DISCONNECTED*

Example:

```
20 2020/11/18 16:47:25 [INFO] CONTROL UNIT MODBUS connection CONNECTED
```

### 9.3.12 Session authentication

The status of the session authentication and the interface used (USB/ETH) are logged.

Format: *Session OPEN/CLOSE/WRONG PASSWORD/UNSET PASSWORD/TIMEOUT/CHANGE PASSWORD via USB/ETH*

Example:

```
20 2020/11/18 16:47:25 [INFO] CONTROL UNIT Session OPEN via USB
```

### 9.3.13 Validation

Every time a validation activity starts or ends on the device, it is logged. The interface used (USB/ETH) is logged as well.

Format: *Validation STARTED/ENDED via USB/ETH*

Example:

```
20 2020/11/18 16:47:25 [INFO] CONTROL UNIT Validation STARTED via USB
```

### 9.3.14 Log download

Every time a log download is performed on the device, it is logged. The interface used (USB/ETH) is logged as well.

Format: *Log download via USB/ETH*

Example:

```
20 2020/11/18 16:47:25 [INFO] CONTROL UNIT Log download via USB
```

## 9.4 ERROR events (control unit)

### 9.4.1 Introduction

A diagnostic error is logged every time the periodic diagnostic functions detect a coming or going fault on the control unit.

### 9.4.2 Temperature errors (TEMPERATURE ERROR)

Error	Meaning
<b>BOARD TEMPERATURE TOO LOW</b>	Board temperature below minimum
<b>BOARD TEMPERATURE TOO HIGH</b>	Board temperature above maximum

### 9.4.3 Control unit voltage errors (POWER ERROR)

Error	Meaning
<b>Control unit voltage UNDERVOLTAGE</b>	Undervoltage error for the indicated voltage
<b>Control unit voltage OVERVOLTAGE</b>	Overvoltage error for the indicated voltage
<b>ADC CONVERSION ERROR</b>	ADC conversion error in the micro-controller

The following table describes the control unit voltage:

Screen printing	Description
<b>VIN</b>	Power supply voltage (+24 V DC)
<b>V12</b>	Internal supply voltage
<b>V12 sensors</b>	Sensors power supply voltage
<b>VUSB</b>	USB port voltage
<b>VREF</b>	Inputs reference voltage ( <b>VSNS Error</b> )
<b>ADC</b>	Analog-digital converter

### 9.4.4 Peripheral error (PERIPHERAL ERROR)

Error detected by diagnostics relative to the micro-controller, its internal peripherals or memories.

### 9.4.5 Configuration errors (FEE ERROR)

Indicates that the system must still be configured. This message can appear when the system is first turned on or after reset to default values. It can also represent another error on the FEE (internal memory).

### 9.4.6 Output errors (OSSD ERROR)

Error	Meaning
<b>OSSD 1 SHORT-CIRCUIT</b>	Short-circuit error on MOS output 1
<b>OSSD 2 SHORT-CIRCUIT</b>	Short-circuit error on MOS output 2
<b>OSSD 3 SHORT-CIRCUIT</b>	Short-circuit error on MOS output 3
<b>OSSD 4 SHORT-CIRCUIT</b>	Short-circuit error on MOS output 4
<b>OSSD 1 NO LOAD</b>	No load on OSSD 1
<b>OSSD 2 NO LOAD</b>	No load on OSSD 2
<b>OSSD 3 NO LOAD</b>	No load on OSSD 3
<b>OSSD 4 NO LOAD</b>	No load on OSSD 4

### 9.4.7 Flash errors (FLASH ERROR)

A flash error represents an error on the external flash.

### 9.4.8 Dynamic configuration error (DYNAMIC CONFIGURATION ERROR)

A dynamic configuration error indicates an invalid dynamic configuration ID.

### 9.4.9 Internal communication error (INTERNAL COMMUNICATION ERROR)

Indicates that there is an internal communication error.

### 9.4.10 Input redundancy error (INPUT REDUNDANCY ERROR)

Error	Meaning
<b>INPUT 1</b>	Error in the redundancy on Input 1
<b>INPUT 2</b>	Error in the redundancy on Input 2
<b>ENCODING</b>	Invalid encoding when the encoded channel option is enabled
<b>PLAUSIBILITY</b>	0->1->0 transition not compliant with input functionality specification

### 9.4.11 Fieldbus error (FIELDBUS ERROR)

At least one of the inputs and outputs has been configured as **Fieldbus controlled**, but the Fieldbus communication is not established or not valid.

Error	Meaning
<b>NOT VALID COMMUNICATION</b>	Error on the Fieldbus

### 9.4.12 RAM error (RAM ERROR)

Error	Meaning
<b>INTEGRITY ERROR</b>	Wrong integrity check on the RAM

### 9.4.13 SD Backup or restore error (SD BACKUP OR RESTORE ERROR)

Error	Meaning
<b>GENERIC FAIL</b>	Unknown fault
<b>TIMEOUT</b>	Writing and reading internal operation timeout
<b>NO_SD</b>	microSD not present
<b>WRITE OPERATION FAILED</b>	Writing error on the microSD card
<b>CHECK OPERATION FAILED</b>	File corrupted or no file during restore from microSD card

### 9.4.14 Sensor configuration errors (SENSOR CONFIGURATION ERROR)

Error occurred on the sensors during the configuration process or at the system power up. At least one of the connected sensors did not get the correct configuration.

As details, the list of sensors not configured is reported.

## 9.5 ERROR events (sensor)

### 9.5.1 Introduction

A diagnostic error is logged every time the periodic diagnostic functions detect a coming or going fault on the sensor.



**WARNING! No sensor errors are available if the sensor is in muting.**

*Note: if requested by Technical Support, in **Settings** > **Activity History**, click **Download sensor debug info** to download the files and forward them to Inxpect for debugging.*

### 9.5.2 Sensor configuration error (SENSOR CONFIGURATION ERROR)

Error occurred on the sensors during the configuration process or at the system power up. At least one of the connected sensors is not correctly configured.

The list of sensor configuration errors is the following:

Error	Meaning
<b>UNKNOWN MODEL-TYPE</b>	Unknown model-type
<b>WRONG MODEL-TYPE</b>	Model-type different from the one set during system configuration
<b>RADIO BANDWIDTH n.a.</b>	Selected radio bandwidth not supported
<b>STATIC OBJECT DETECTION n.a.</b>	Static object detection not supported
<b>CUSTOM TARGET DETECTION n.a.</b>	Custom target detection not supported
<b>ADVANCED FOV n.a.</b>	Advanced field of view not supported
<b>ANTI-MASKING REF</b>	Error occurred during the anti-masking reference grabbing
<b>ANTI-ROTATION REF</b>	Error occurred during the anti-rotation around axes reference grabbing
<b>TIMEOUT</b>	Timeout error occurred during the system recondition
<b>ASSIGN NODE ID ERROR</b>	Error occurred during the Node ID setting of the system recondition



Error	Meaning
<b>SEQUENCE, STREAM SEQUENCE, STREAM END, STREAM CRC</b>	Sequence error occurred during the sensor configuration
<b>MISSING SENSORS</b>	Too many sensors are missing during the system recondition

### 9.5.3 Misconfiguration error (MISCONFIGURATION ERROR)

The misconfiguration error occurs when the sensor does not have a valid configuration or it has received an invalid configuration from the control unit.

### 9.5.4 Status error and fault (STATUS ERROR/FAULT ERROR)

The status error occurs when the sensor is in an internal invalid status or it has reached an internal fault condition.

### 9.5.5 Protocol error (PROTOCOL ERROR)

The protocol error occurs when the sensor receives commands with an unknown format.

### 9.5.6 Sensor voltage errors (POWER ERROR)

Error	Meaning
<b>Sensor voltage UNDERVOLTAGE</b>	Undervoltage error for the indicated voltage
<b>Sensor voltage OVERVOLTAGE</b>	Overvoltage error for the indicated voltage

The following table describes the sensor voltage:

Screen printing	Description
<b>VIN</b>	Power supply voltage (+12 V DC)
<b>V3.3</b>	Internal chip power supply voltage
<b>V1.2</b>	Micro-controller power supply voltage
<b>V1.8</b>	Internal chip power supply voltage (1.8 V)
<b>V1</b>	Internal chip power supply voltage (1 V)

### 9.5.7 Anti-tampering sensor (TAMPER ERROR)

Error	Meaning
<b>TILT ANGLE ERROR</b>	Sensor rotation around the x-axis
<b>ROLL ANGLE ERROR</b>	Sensor rotation around the z-axis
<b>PAN ANGLE ERROR</b>	Sensor rotation around the y-axis

*Note: the information of the angle (in degrees) is reported.*

### 9.5.8 Signal error (SIGNAL ERROR)

The signal error occurs when the sensor detected an error in the RF signals part, in particular:

Error	Meaning
<b>MASKING</b>	The sensor is obstructed
<b>MASKING REFERENCE MISSING</b>	During the configuration process, it was not possible to get the masking reference
<b>SIGNAL PATTERN ERROR</b>	Radar internal fault or unexpected signal pattern

## 9.5.9 Temperature errors (TEMPERATURE ERROR)

Error	Meaning
<b>BOARD TEMPERATURE TOO LOW</b>	Board temperature below minimum
<b>BOARD TEMPERATURE TOO HIGH</b>	Board temperature above maximum
<b>CHIP TEMPERATURE TOO LOW</b>	Internal chip below minimum
<b>CHIP TEMPERATURE TOO HIGH</b>	Internal chip above maximum
<b>IMU TEMPERATURE TOO LOW</b>	IMU below minimum
<b>IMU TEMPERATURE TOO HIGH</b>	IMU above maximum

## 9.5.10 MSS error and DSS error (MSS ERROR/DSS ERROR)

Error detected by diagnostics relative to the internal micro-controllers (MSS and DSS), their internal peripherals or memories

## 9.6 ERROR events (CAN bus)

### 9.6.1 Introduction

A diagnostic error is logged every time the periodic diagnostic functions detect a coming or going fault on the CAN bus communication.

Depending on the communication bus side, the logged source can be the control unit or a single sensor.

### 9.6.2 CAN errors (CAN ERROR)

Error	Meaning
<b>TIMEOUT</b>	Timeout on message to sensor/control unit
<b>CROSS CHECK</b>	Two redundant messages do not coincide
<b>SEQUENCE NUMBER</b>	Message with sequence number different from the expected number
<b>CRC CHECK</b>	Packet control code does not match
<b>COMMUNICATION LOST</b>	Impossible to communicate with the sensor
<b>PROTOCOL ERROR</b>	Control unit and sensors have different and incompatible firmware versions
<b>POLLING TIMEOUT</b>	Timeout on data polling

**NOTICE:** A shielded cable between the control unit and the first sensor, and between the sensors is strongly recommended. Nevertheless, route the CAN cables separately from high-potential power lines or through an exclusive conduit.

# 10. Maintenance

---

## Contents

This section includes the following topics:

<b>10.1 Planned maintenance</b> .....	<b>99</b>
<b>10.2 Extraordinary maintenance</b> .....	<b>100</b>

## 10.1 Planned maintenance

---

### Generic maintenance technician

The generic maintenance technician is a person qualified only to perform basic maintenance without the administrator privileges required to modify the configuration of Inxpect SRE 200 Series through the application.

#### 10.1.1 Cleaning

Keep the sensor clean and free of any work residues and conductive material to prevent masking and/or poor system operation.

#### 10.1.2 Spare parts

##### Control units

Model-type	Part number
C201A-PNS	90301011
C201A-F	90301012
C202A	90303011
C203A	90304011
C201B-P	90301111
C201B-F	90301112
C202B	90303111
C203B	90304111

##### Sensors

Model-type	Part number
S201A-MLR	90305010
S201A-WL	90305111
S203A-WL	90306111

##### Cables

Product	Part number
CU-SENS 5 m	08000110
CU-SENS 10 m	08000111
CU-SENS 15 m	08000112
CU-SENS 20 m	08000113
SENS-SENS 3 m	08000120
SENS-SENS 5 m	08000121
SENS-SENS 10 m	08000122
SENS-SENS 15 m	08000123

## Accessories

Product	Part number
Bus terminator	07000003
3-axes bracket	90302ZAA
Rough indoor adjustable support kit	90302ZAC
Rough outdoor adjustable support kit	90302ZAD
microSD Industrial Grade	X0000011

## 10.2 Extraordinary maintenance

### 10.2.1 Machinery maintenance technician

The machinery maintenance technician is a qualified person with the administrator privileges required to modify the configuration of Inxpect SRE 200 Series through the Inxpect Safety application and perform maintenance and troubleshooting.

### 10.2.2 Control unit firmware update

1. Download the latest Inxpect Safety application version from the <https://tools.inxpect.com> website and install it on your computer.
2. Connect to the control unit via Ethernet and log in as Admin.  
**Note:** update via USB is available only for C203A and C203B.
3. In **Settings > General**, check if a new update is available.
4. Update without disconnecting from or turning off the device.

### 10.2.3 Replace a sensor: System recondition function

The system recondition function is useful for replacing an existing sensor without changing current settings. The function can be enabled through digital inputs (**System recondition** or **Restart signal + System recondition**) or via Fieldbus (**System recondition** only).



**WARNING! If the system recondition function has been configured through the safety Fieldbus and the digital inputs, the function can be used from both.**

**Note:** keep the scene static while running the system recondition function so that the anti-tampering functions can save their references.

**Note:** while running the system recondition function, the system goes to the safe state, deactivating the OSSDs, until the process is completed.

1. Configure the digital inputs or Fieldbus to perform the system recondition function.
2. Connect a sensor without Node ID in the same position of the CAN bus line as the replaced sensor.  
**Note:** only one sensor at a time must be connected to complete the procedure correctly.
3. Activate the function (via digital inputs or Fieldbus) and wait for the operation to be performed. See "Control unit LED" on page 85 to know which is the system status.

The following actions are performed:

- The first available Node ID is assigned to the new sensor.
- The previous configuration of the system is applied (**APPLY CHANGES** operation).
- The event is logged in the reports archive (**Settings > Activity History > Configuration reports page**) with the following strings in the **User, PC** column:
  - "sys-recondition-i" when the function is performed via digital input
  - "sys-recondition-f" when Fieldbus is used

**Note:** for more details, see "Digital input signals" on page 120.

## 10.2.4 Back up the configuration to a PC

The current configuration can be backed up, including the input/output settings. The configuration is saved in a .cfg file, which can be used to restore the configuration or to facilitate configuration of several Inxpect SRE 200 Series.

1. In **Settings > General**, click **BACKUP**.
2. Select the file destination and save.

**Note:** user login credentials are not saved using this backup mode.

## 10.2.5 Back up the configuration to a microSD card

If the control unit is provided with a microSD slot, a backup file of the system settings, and (optionally) the login credentials of all the users, can be stored on the microSD card. The SD Backup function can be enabled/disabled through the Inxpect Safety application, as well as the backup of the login credentials of all the users. By default, both options are disabled.

1. To enable the SD Backup function, in **Admin > SD Card** select **Automatic backup creation**.
2. To enable the saving of all users' login credentials, select **Users data included**.
3. To perform the backup, insert a microSD card into the control unit memory card slot.

**Note:** the microSD card is not supplied with the control unit. For details about the microSD card specifications, see "microSD card specifications" below

4. In the Inxpect Safety application, click **APPLY CHANGES**: the backup is automatically performed.

## 10.2.6 Load a configuration from a PC

1. In **Settings > General**, click **RESTORE**.
2. Select the previously saved .cfg file (see "Back up the configuration to a PC" above) and open it.

**Note:** a re-imported configuration requires new downloading onto the control unit and approval according to the safety plan.

## 10.2.7 Load a configuration from a microSD card

If the control unit is provided with a microSD slot, the administrator can restore both the system settings and (if any) the login credentials of all the users. This requires a valid backup file saved on a microSD. The SD Restore function can be enabled/disabled through the Inxpect Safety application. By default the option is enabled.

**Note:** this SD Restore function also includes a System recondition operation, see "Replace a sensor: System recondition function" on the previous page.

1. To perform the restore, insert the microSD card with the saved configuration into the memory card slot of the new control unit.

**Note:** the microSD card is not supplied with the control unit. For details about the microSD card specifications, see "microSD card specifications" below

2. Press the SD Restore button on the control unit: the restore is performed.

**Note:** to disable the SD Restore function, in **Admin > SD Card** deselect **Enable restore by button**

The following actions are performed:

- The system configuration is applied (**APPLY CHANGES** operation).
- The event is logged in the reports archive (**Settings > Activity History > Configuration reports page**) with the string **Restore-via-sdcard**.

## 10.2.8 microSD card specifications

<b>Type</b>	microSD
<b>File system</b>	FAT32
<b>Recommended capacity</b>	32 GB or less

# 11. Technical references

---

## Contents

This section includes the following topics:

<b>11.1 Technical data</b> .....	<b>103</b>
<b>11.2 Terminal blocks and connector pin-outs</b> .....	<b>106</b>
<b>11.3 Electrical connections</b> .....	<b>108</b>
<b>11.4 Configuration application parameters</b> .....	<b>115</b>
<b>11.5 Digital input signals</b> .....	<b>120</b>

## 11.1 Technical data

### 11.1.1 General specifications

<b>Detection method</b>	Inxpect motion detection algorithm based on FMCW radar
<b>Frequency</b>	Working band: <ul style="list-style-type: none"> <li>for S201A model: 60.6-62.8 GHz</li> <li>for S203A model: 61.2-63.4 GHz</li> </ul> Maximum radiated power: 16 dBm mean EIRP Modulation: FMCW
<b>Detection interval</b>	<ul style="list-style-type: none"> <li>Access detection: from 0 to 9 m (from 0 to 29.5 ft)</li> <li>Restart prevention: from 0 to 5 m (from 0 to 16.4 ft)</li> </ul>
<b>Detectable target RCS (Human detection)</b>	0.17 m <sup>2</sup>
<b>Field of view</b>	Horizontal coverage programmable depending on distance: <ul style="list-style-type: none"> <li>in the first 5 m (16.4 ft), from 10° to 100°</li> <li>from 5 to 9 m (from 16.4 to 29.5 ft), from 10° to 40°</li> </ul> Vertical coverage <ul style="list-style-type: none"> <li>S201A model: 20°</li> <li>S203A model: 12°</li> </ul>
<b>Decision probability</b>	> 1-(2.5E-07)
<b>CRT (Certified Restart Timeout)</b>	4 s
<b>Guaranteed response time</b>	Access detection: < 100 ms * Restart prevention: 4000 ms
	 <b>WARNING! During the real-time validation and the download of the log file, the response time is not guaranteed.</b>
<b>Total consumption</b>	Max. 25.4 W (control unit and six sensors)
<b>Electrical protections</b>	Polarity inversion Overcurrent through resettable integrated fuse (max. 5 s @ 8 A)
<b>Overvoltage category</b>	II
<b>Altitude</b>	Max. 1500 m ASL
<b>Air humidity</b>	Max. 95%
<b>Noise emission</b>	Negligible**

**Note\*:** the value depends on the Electromagnetic robustness level set through the Inxpect Safety application, see "Electromagnetic Robustness" on page 52.

**Note\*\*:** the A-weighted emission sound pressure level does not exceed 70 dB(A).

### 11.1.2 Safety parameters

<b>SIL (Safety Integrity Level)</b>	2
<b>HFT</b>	0

<b>SC*</b>	2
<b>TYPE</b>	B
<b>PL (Performance Level)</b>	d
<b>ESPE Type (EN 61496-1)</b>	3
<b>Category (EN ISO 13849)</b>	3 equivalent
<b>Class (IEC TS 62998-1)</b>	D
<b>Communication protocol (sensors-control unit)</b>	CAN complies with standard EN 50325-5
<b>Mission time</b>	20 years
<b>MTTF<sub>D</sub></b>	42 years
<b>PFH<sub>D</sub></b>	With Fieldbus communication: <ul style="list-style-type: none"> <li>Access detection: 1.40E-08 [1/h]</li> <li>Restart prevention: 1.40E-08 [1/h]</li> <li>Muting: 6.37E-09 [1/h]</li> <li>Stop signal: 6.45E-09 [1/h]</li> <li>Restart signal: 6.45E-09 [1/h]</li> <li>Dynamic Configuration Switch: 6.37E-09 [1/h]</li> <li>Fieldbus controlled: 6.45E-09 [1/h]</li> </ul> Without Fieldbus communication: <ul style="list-style-type: none"> <li>Access detection: 1.30E-08 [1/h]</li> <li>Restart prevention: 1.30E-08 [1/h]</li> <li>Muting: 5.37E-09 [1/h]</li> <li>Stop signal: 5.45E-09 [1/h]</li> <li>Restart signal: 5.45E-09 [1/h]</li> <li>Dynamic Configuration Switch: 5.37E-09 [1/h]</li> <li>Fieldbus controlled: 5.45E-09 [1/h]</li> </ul>
<b>SFF</b>	≥ 99.89%
<b>DCavg</b>	≥ 99.46%
<b>MRT**</b>	< 10 min
<b>Safe state when a fault occurs</b>	At least one channel for each safety output is in OFF-state. Stop message sent on Fieldbus (if available) or communication interrupted

**Note\*:** the systematic capability is guaranteed only if the user uses the product according to the instructions of this manual and uses the product in the appropriate environment.

**Note\*\*:** the MRT considered is the Technical Mean Repair Time, i.e., it takes in consideration availability of skilled personnel, adequate tools and spare parts. Considering the type of device, the MRT corresponds to the time necessary for the device replacement.

### 11.1.3 Ethernet connection (if available)

<b>Default IP address</b>	192.168.0.20
<b>Default TCP port</b>	80
<b>Default netmask</b>	255.255.255.0
<b>Default gateway</b>	192.168.0.1

## 11.1.4 Control unit features

<b>Outputs</b>	Configurable as follows: <ul style="list-style-type: none"> <li>4 Output Signal Switching Devices (OSSDs) (used as single channels)</li> <li>2 dual channel safety outputs</li> <li>1 dual channel safety output and 2 Output Signal Switching Devices (OSSDs)</li> </ul>
<b>OSSD characteristic</b>	<ul style="list-style-type: none"> <li>Maximum resistive load: 100 K<math>\Omega</math></li> <li>Minimum resistive load: 70 <math>\Omega</math></li> <li>Maximum capacitive load: 1000 nF</li> <li>Minimum capacitive load: 10 nF</li> </ul>
<b>Safety outputs</b>	High-side outputs (with extended protection function) <ul style="list-style-type: none"> <li>Maximum current: 0.4 A</li> <li>Maximum power: 12 W</li> </ul> <p>The OSSDs provide what follows:</p> <ul style="list-style-type: none"> <li>ON-state: from <math>U_v-1V</math> to <math>U_v</math> (<math>U_v = 24V \pm 4V</math>)</li> <li>OFF-state: from 0 V to 2.5 V r.m.s.</li> </ul>
<b>Inputs</b>	Configurable as follows: <ul style="list-style-type: none"> <li>4 single channel (cat. 2) type 3 digital inputs with common GND</li> <li>2 dual channel (cat. 3) type 3 digital inputs with common GND</li> <li>1 dual channel (cat. 3) and 2 single channels (cat. 2) type 3 digital inputs with common GND</li> </ul> <p>See "Voltage and current limits for digital inputs" on page 106.</p>
<b>Fieldbus interface (if available)</b>	Ethernet based interface with different standard Fieldbus (e.g., PROFI-safe, FSoE)
<b>Power supply</b>	24 V DC (20–28 V DC) * Maximum current: 1 A
<b>Consumption</b>	Max. 5 W
<b>Assembly</b>	On DIN rail
<b>Weight</b>	For Type A: with cover: 170 g (6 oz) For Type B: with cover: 160 g (5.7 oz)
<b>Degree of protection</b>	IP20
<b>Terminals</b>	Section: 1 mm <sup>2</sup> (16 AWG) max. Maximum current: 4 A with 1 mm <sup>2</sup> cables (16 AWG)
<b>Impact test</b>	For Type A: 0.5 J, 0.25 kg ball from a 20 cm height For Type B: 1 J, 0.25 kg ball from a 40 cm height
<b>Shock/Bump</b>	For Type A: in accordance with IEC/EN 61496-1:2013 sec. 5.4.4.2 (IEC 60068-2-27) For Type B: in accordance with IEC/EN 61496-1:2020 sec. 5.4.4.2 class 5M3 (IEC 60068-2-27)
<b>Vibration</b>	For Type A: in accordance with IEC/EN 61496-1:2013 sec. 5.4.4.1 (IEC 60068-2-6) For Type B: in accordance with IEC/EN 61496-1:2020 sec. 5.4.4.1 class 5M3 (IEC 60068-2-6 and IEC 60068-2-64)
<b>Pollution degree</b>	2
<b>Outdoor use</b>	No
<b>Operating temperature</b>	From -30 to +60 °C (from -22 to +140 °F)
<b>Storage temperature</b>	From -40 to +80 °C (from -40 to +176 °F)

**Note\*:** the unit shall be supplied by an isolated power source which fulfils the requirements of:

- Limited-Energy Circuit in accordance with IEC/UL/CSA 61010-1/ IEC/UL/CSA 61010-2-201 or
- Limited Power Source (LPS) in accordance with IEC/UL/CSA 60950-1 or
- (For North America and/or Canada only) a Class 2 supply source which complies with the National Electrical Code (NEC), NFPA 70, Clause 725.121 and Canadian Electrical Code (CEC), Part I, C22.1. (typical examples are a Class 2 transformer or a Class 2 power sources in compliance with, UL 5085-3/ CSA-C22.2 No. 66.3 or UL 1310/CSA-C22.2 No. 223).

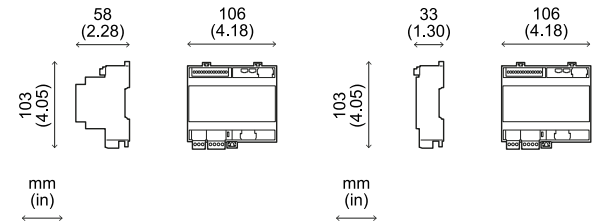

Type A

Type B

## 11.1.5 Sensor features

<b>Connectors</b>	2 5-pin M12 connectors (1 male and 1 female)
<b>CAN bus termination resistance</b>	120 $\Omega$ (not supplied, to be installed with a bus terminator)
<b>Power supply</b>	12 V DC $\pm$ 20%, through control unit
<b>Consumption</b>	Average 2.2 W Peak 3.4 W
<b>Degree of protection</b>	Type 3 enclosure, according to UL 50E, in addition to IP 67 rating
<b>Material</b>	Sensor: PA66 Bracket: PA66 and glass fiber (GF)
<b>Frame rate</b>	62 fps
<b>Weight</b>	With 2-axes bracket: 300 g (10.6 oz) With 3-axes bracket: 355 g (12.5 oz)
<b>Shock/Bump</b>	For S201A model: in accordance with IEC/EN 61496-1:2013 sec. 5.4.4.2 (IEC 60068-2-27) For S203A model: in accordance with IEC/EN 61496-1:2020 sec. 5.4.4.2 class 5M3 (IEC 60068-2-27)
<b>Vibration</b>	For S201A model: in accordance with IEC/EN 61496-1:2013 sec. 5.4.4.1 (IEC 60068-2-6) For S203A model: in accordance with IEC/EN 61496-1:2020 sec. 5.4.4.1 class 5M3 (IEC 60068-2-6 and IEC 60068-2-64)
<b>Pollution degree</b>	4
<b>Outdoor use</b>	Yes
<b>Operating temperature</b>	From -30 to +60 °C (from -22 to +140 °F)*
<b>Storage temperature</b>	From -40 to +80 °C (from -40 to +176 °F)



**Note\***: in environmental conditions where the operating temperature can reach values higher than the supported range, install a cover to shield the sensor from sun rays.

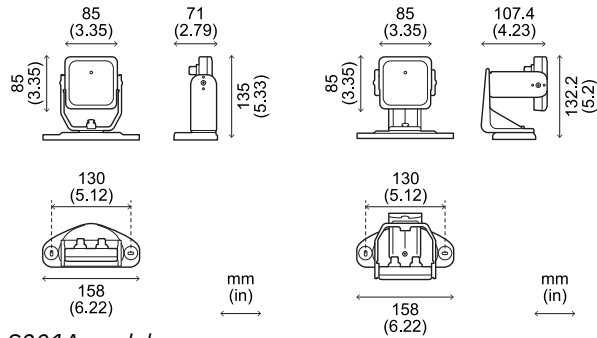

S201A model

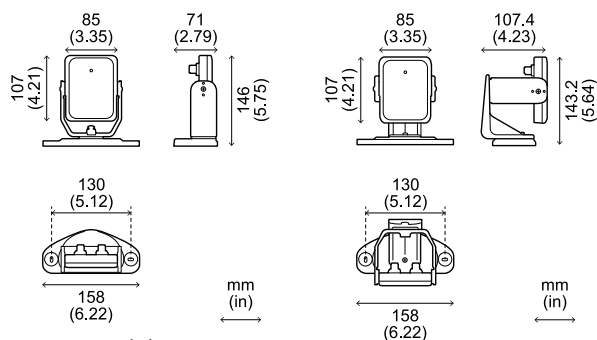

S203A model

### 11.1.6 CAN bus cables recommended specifications

<b>Section</b>	2 x 0.50 mm <sup>2</sup> (21 AWG) power supply 2 x 0.22 mm <sup>2</sup> (24 AWG) data line
<b>Type</b>	Two twisted pairs (power supply and data) and one drain wire (or shield)
<b>Connectors</b>	5-pole M12 (see "Connectors M12 CAN bus" on page 107) Connectors shall be type 3 (raintight)
<b>Impedance</b>	120 Ω ±12 Ω (f = 1 MHz)
<b>Shield</b>	Shield with twisted wires in tin-plated copper. To be connected to ground circuit on the power supply terminal block of the control unit.
<b>Standards</b>	Cables shall be listed in accordance with application as described in the National Electrical Code, NFPA 70, and in the Canadian Electrical Code, C22.1. Total maximum length of the CAN bus line: 100 m (328.1 ft)

### 11.1.7 Tamper-proof screws specifications

#### Pin Hex button head security screw

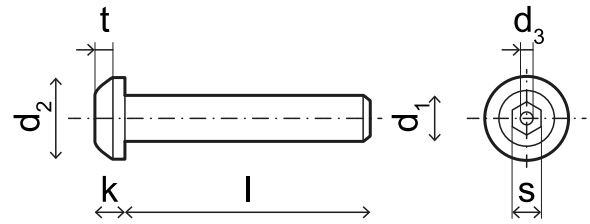

$d_1$	M4
$l$	10 mm (0.39 in)
$d_2$	7.6 mm (0.30 in)
$k$	2.2 mm (0.09 in)
$t$	min 1.3 mm (0.05 in)
$s$	2.5 mm (0.10 in)
$d_3$	max. 1.1 mm (0.04 in)

### 11.1.8 Non tamper-proof screws specifications

#### Hex button head screw

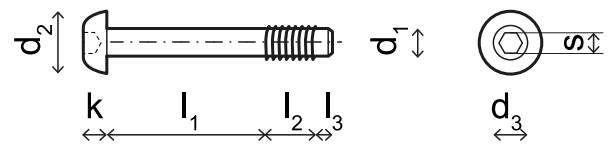

$d_1$	M4
$l_1$	19 mm (0.74 in)
$l_2$	6 mm (0.23 in)
$l_3$	2 mm (0.07 in)
$d_2$	7.6 mm (0.30 in)
$k$	3 mm (0.11 in)
$s$	2.5 mm (0.10 in)
$d_3$	4 mm (0.15 in)

### 11.1.9 Bottom screws specifications

The bottom screws can be:

- cheese head
- button head

**Note:** avoid using countersunk head screws.

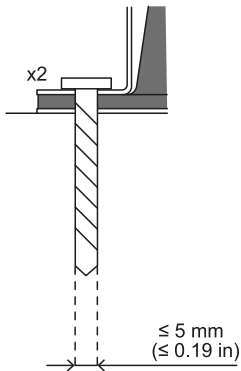

## 11.2 Terminal blocks and connector pin-outs

### 11.2.1 Digital inputs and outputs terminal block

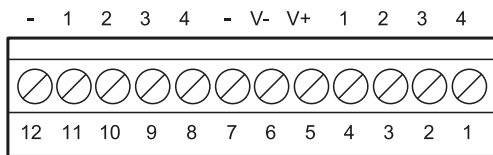

**Note:** facing the control unit so that the terminal block is on the top left, number 12 is the closest to the control unit corner.

Terminal block	Symbol	Description	Pin
Digital In	4	Input 2, Channel 2, 24 V DC type 3 - INPUT #2-2	1
	3	Input 2, Channel 1, 24 V DC type 3 - INPUT #2-1	2
	2	Input 1, Channel 2, 24 V DC type 3 - INPUT #1-2	3
	1	Input 1, Channel 1, 24 V DC type 3 - INPUT #1-1	4
	V+	V+ (SNS), 24 V DC for diagnostics of the digital inputs (mandatory if at least one input is used)	5
	V-	V- (SNS), common reference for all digital inputs (mandatory if at least one input is used)	6

Terminal block	Symbol	Description	Pin
Digital Out	-	GND, common reference for all digital outputs	7
	4	Output 4 (OSSD4)	8
	3	Output 3 (OSSD3)	9
	2	Output 2 (OSSD2)	10
	1	Output 1 (OSSD1)	11
	-	GND, common reference for all digital outputs	12

**Note:** the cables used must have a maximum length of 30 m (98.4 ft) and the maximum operating temperature must be at least 80 °C.

**Note:** use only copper wires with a minimum gauge of 18 AWG and a torque of 0.62 Nm (5,5 lbs in).

### 11.2.2 Voltage and current limits for digital inputs

The digital inputs (input voltage 24 V DC) adhere to the following voltage and current limits, in accordance with standard IEC/EN 61131-2:2003.

Type 3	
<b>Voltage limits</b>	
0	from - 3 to 11 V
1	from 11 to 30 V
<b>Current limits</b>	
0	15 mA
1	from 2 to 15 mA

### 11.2.3 Power supply terminal block

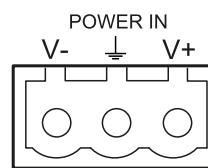

**Note:** connector front view.

Symbol	Description
V-	GND
	Earth
V+	+ 24 V DC

**Note:** the maximum operating temperature of the cables must be at least 70 °C.

**Note:** use only copper wires with a minimum gauge of 18 AWG and a torque of 0.62 Nm (5,5 lbs in).

### 11.2.4 CAN bus terminal block

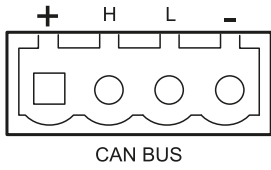

Symbol	Description
+	+ 12 V DC output
H	CAN H
L	CAN L
-	GND

**Note:** the maximum operating temperature of the cables must be at least 70 °C.

### 11.2.5 Connectors M12 CAN bus

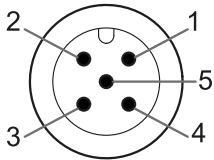

Male connector

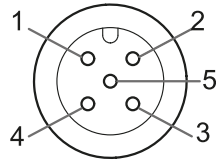

Female connector

Pin	Function
1	Shield to be connected to the functional earth on the power supply terminal block of the control unit.
2	+ 12 V DC
3	GND
4	CAN H
5	CAN L

## 11.3 Electrical connections

### 11.3.1 Connection of safety outputs to the Programmable Logic Controller

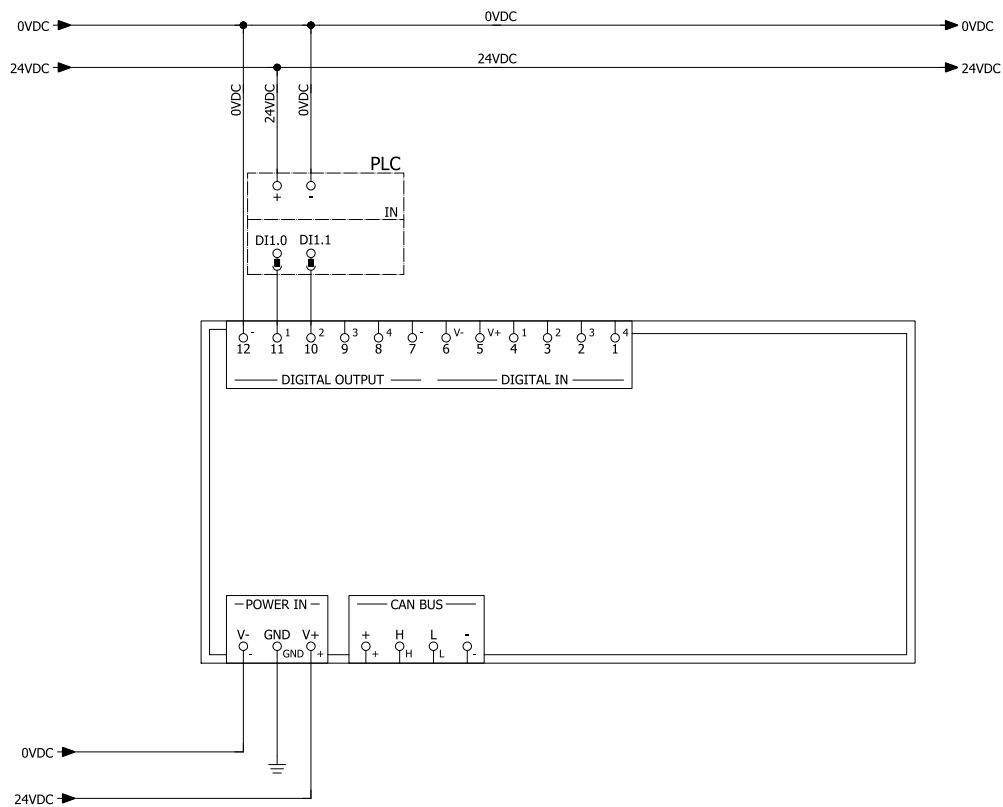

#### Digital I/O settings (through the Inxpect Safety application)

Digital input #1 Not configured

Digital input #2 Not configured

Digital output #1 Detection signal 1

Digital output #2 Detection signal 1

Digital output #3 Not configured

Digital output #4 Not configured

### 11.3.2 Connection of safety outputs to an external safety relay

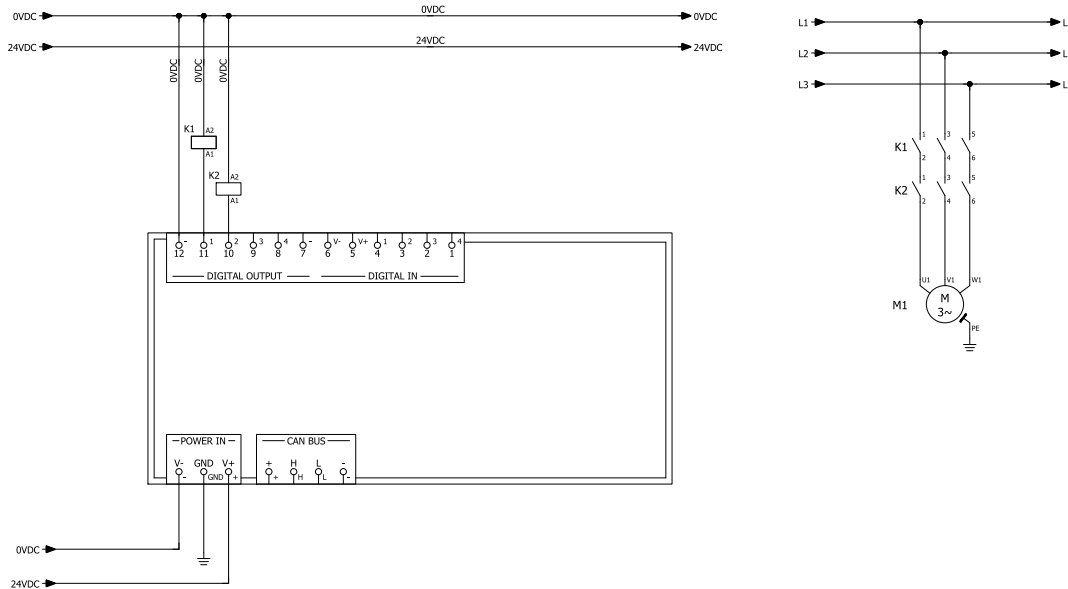

#### Digital I/O settings (through the Inxpect Safety application)

Digital input #1 Not configured

Digital input #2 Not configured

Digital output #1 Detection signal 1

Digital output #2 Detection signal 1

Digital output #3 Not configured

Digital output #4 Not configured

### 11.3.3 Connection of stop signal (Emergency button)

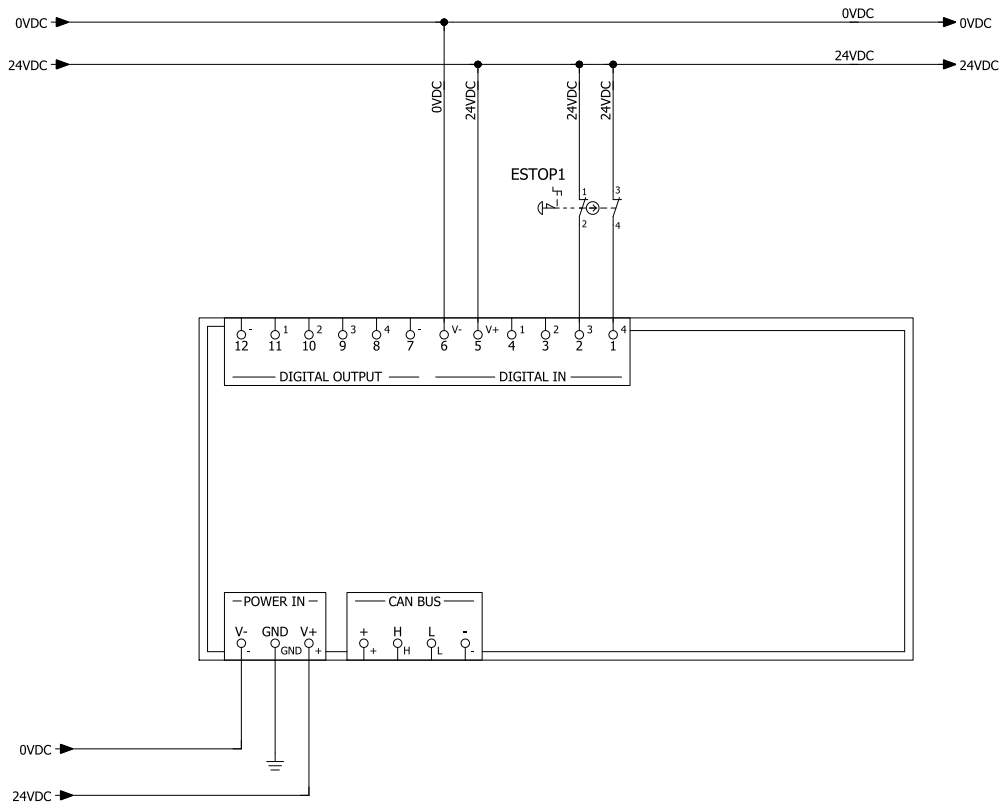

**Note:** the indicated emergency button opens the contact when pressed.

**Note:** the cables used for wiring the digital inputs must have a maximum length of 30 m (98.4 ft).

#### Digital I/O settings (through the Inxpect Safety application)

- Digital input #1 Not configured
- Digital input #2 Stop signal
- Digital output #1 Not configured
- Digital output #2 Not configured
- Digital output #3 Not configured
- Digital output #4 Not configured

### 11.3.4 Connection of restart signal (dual channel)

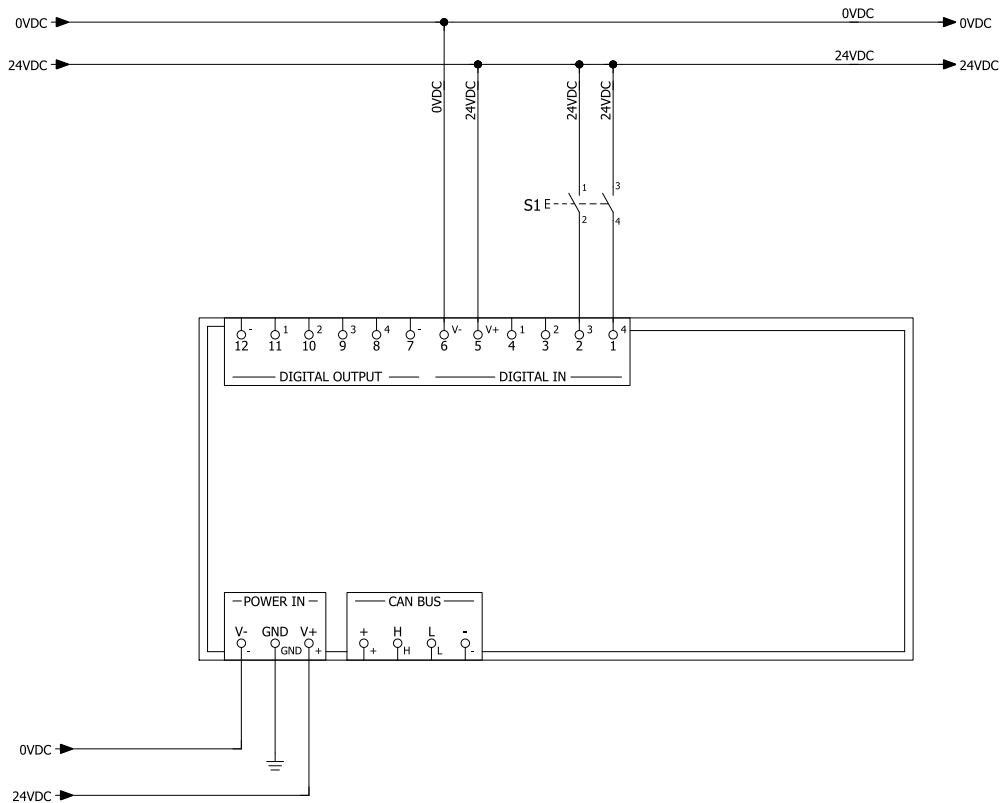

**Note:** the button indicated for the restart signal closes the contact when pressed.

**Note:** the cables used for wiring the digital inputs must have a maximum length of 30 m (98.4 ft).

#### Digital I/O settings (through the Inxpect Safety application)

Digital input #1 Not configured

Digital input #2 Restart signal

Digital output #1 Not configured

Digital output #2 Not configured

Digital output #3 Not configured

Digital output #4 Not configured

### 11.3.5 Connection of the muting input and output (one group of sensors)

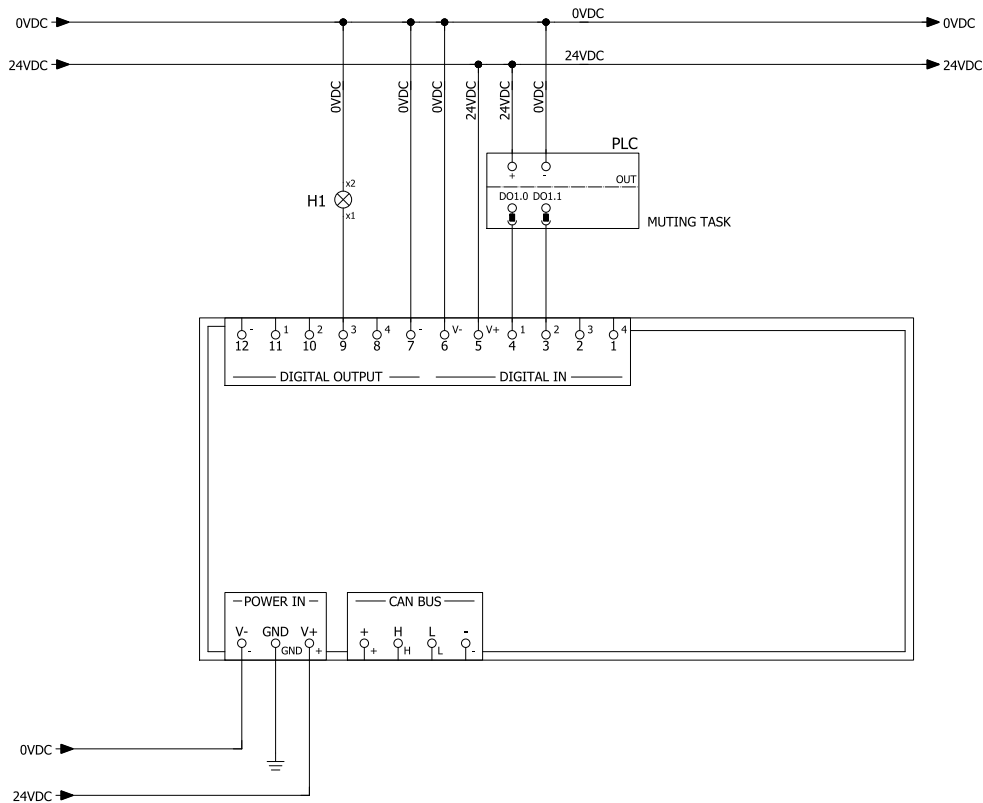

**Note:** the cables used for wiring the digital inputs must have a maximum length of 30 m (98.4 ft).

#### Digital I/O settings (through the Inxpect Safety application)

- Digital input #1 Muting group 1
- Digital input #2 Not configured
- Digital output #1 Not configured
- Digital output #2 Not configured
- Digital output #3 Muting enable feedback signal
- Digital output #4 Not configured



### 11.3.6 Connection of the muting input and output (two groups of sensors)

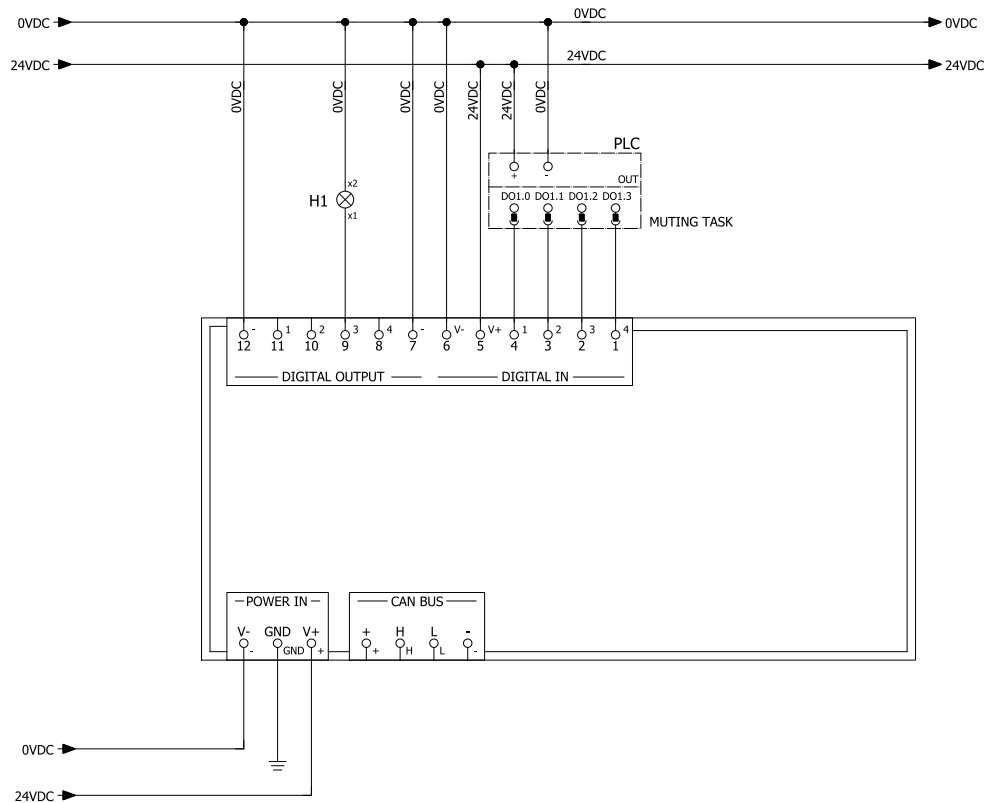

**Note:** the cables used for wiring the digital inputs must have a maximum length of 30 m (98.4 ft).

#### Digital I/O settings (through the Inxpect Safety application)

Digital input #1 Muting group 1

Digital input #2 Muting group 2

Digital output #1 Not configured

Digital output #2 Not configured

Digital output #3 Muting enable feedback signal

Digital output #4 Not configured

### 11.3.7 Detection signal 1 and 2 connection

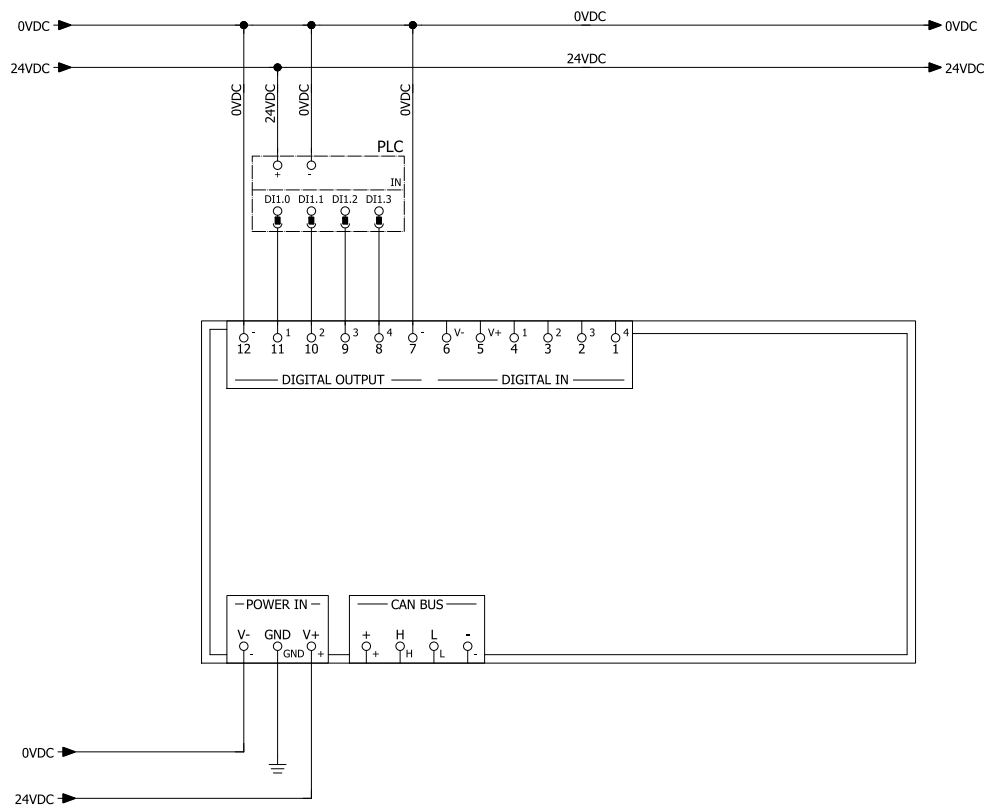

#### Digital I/O settings (through the Inxpect Safety application)

- Digital input #1 Not configured
- Digital input #2 Not configured
- Digital output #1 Detection signal 1
- Digital output #2 Detection signal 1
- Digital output #3 Detection signal 2
- Digital output #4 Detection signal 2

### 11.3.8 Diagnostic output connection

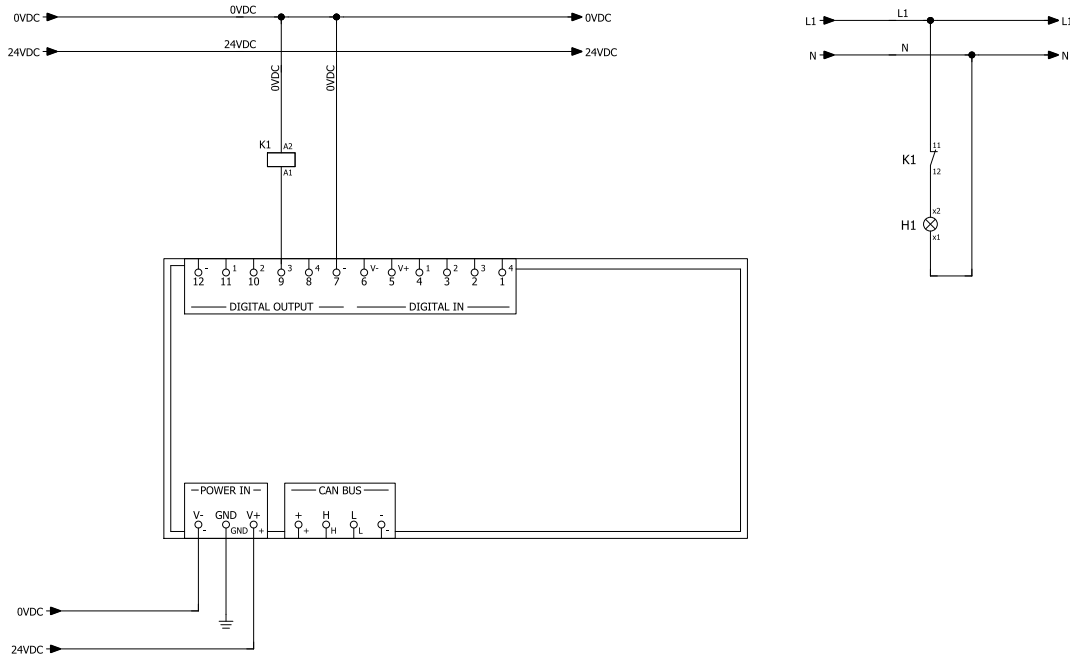

**Note:** the cables used for wiring the digital inputs must have a maximum length of 30 m (98.4 ft).

#### Digital I/O settings (through the Inxpect Safety application)

- Digital input #1 Not configured
- Digital input #2 Not configured
- Digital output #1 Not configured
- Digital output #2 Not configured
- Digital output #3 System diagnostic signal
- Digital output #4 Not configured

## 11.4 Configuration application parameters

### 11.4.1 Parameter list

Parameter	Min	Max	Default value
<b>Settings &gt; Account</b>			
Password	-	-	Not available

11. Technical references

Parameter	Min	Max	Default value
<b>Settings &gt; General</b>			
System	Inxpect SRE 100 Series, Inxpect SRE 200 Series		Inxpect SRE 100 Series
Sensors model and type	5 meters range sensors, 9 meters range sensors		5 meters range sensors
Country	Europe, Rest of the certified countries or list of countries		Europe, Rest of the certified countries
Application type selection	Stationary, Mobile, Vehicle		Stationary
<b>Configuration</b>			
Number of installed sensors	1	6	1
Plane	Dim. X: 1000 mm Dim. Y: 1000 mm	Dim. X: 65000 mm Dim. Y: 65000 mm	Dim. X:10000 mm Dim. Y: 7000 mm
Position (for each sensor)	X: 0 mm Y: 0 mm	X: 65000 mm Y: 65000 mm	Default position of sensor #1: X: 2000 mm Y: 3000 mm
Rotation 1 (for each sensor)	0°, 90°, 180°, 270°		0°
Rotation 2 (for each sensor)	0°	359°	180°
Rotation 3 (for each sensor)	-90°	90°	0°
Sensor installation height (for each sensor)	0 mm	10000 mm	0 mm
3.x sensors RCS Threshold (for each sensor)	0 dB	70 dB	0 dB
5.x sensors RCS Threshold (for each detection field of each sensor)	0 dB	70 dB	0 dB
Detection Distance 1, 2 (for each sensor)	0 mm <b>Note:</b> the minimum value for the first detection field with distance > 0 is 500 mm for 3.x sensors and 200 mm for 5.x sensors.	9000 mm <b>Note:</b> the sum of all the detection distances (for each sensor) cannot exceed 9000 mm.	1000 mm
Detection Distance 2, 3 and 4 (for each sensor)	0 mm <b>Note:</b> the minimum value for the first detection field with distance > 0 is 500 mm for 3.x sensors and 200 mm for 5.x sensors.	9000 mm <b>Note:</b> the sum of all the detection distances (for each sensor) cannot exceed 9000 mm.	0 mm
For 5.x sensors - Detection area shape	Classic, Corridor		Classic
Angular coverage left (Classic shape), for a total detection distance lower than or equal to 5000 mm	0° <b>Note:</b> the minimum angular coverage (left + right) is 10°	50°	45°
Angular coverage right (Classic shape), for a total detection distance lower than or equal to 5000 mm	0° <b>Note:</b> the minimum angular coverage (left + right) is 10°	50°	45°
Angular coverage left (Classic shape), for a total detection distance greater than 5000 mm	0° <b>Note:</b> the minimum angular coverage (left + right) is 10°	20°	-

Parameter	Min	Max	Default value
Angular coverage right (Classic shape), for a total detection distance greater than 5000 mm)	0° <i>Note: the minimum angular coverage (left + right) is 10°</i>	20°	-
5.x sensors (Corridor shape) – Corridor left	0 mm <i>Note: the minimum corridor width (left + right) is 200 mm in the first 5 m; it is 300 mm between 5 and 9 m.</i>	4000 mm	500 mm
5.x sensors (Corridor shape) – Corridor right	0 mm <i>Note: the minimum corridor width (left + right) is 200 mm in the first 5 m; it is 300 mm between 5 and 9 m.</i>	4000 mm	500 mm
Safety working mode (for each detection field of each sensor)	Access detection and restart prevention, Always-on access detection		Access detection and restart prevention
Static object detection (for each detection field of each sensor)	Enabled, Disabled		Disabled
Restart timeout (for each detection field of each sensor)	100 ms	60000 ms	4000 ms
T <sub>OFF</sub>	100 ms	60000 ms	100 ms
<b>Settings &gt; Advanced</b>			
Detection field dependency	Enabled, Disabled		Enabled
Electromagnetic robustness	Standard, High, Very High		Standard
Static object detection sensitivity	-20 dB	+20 dB	0 dB
<b>Settings &gt; Advanced &gt; Multi-control unit synchronization</b>			
Control unit channel	0	3	0
<b>Settings &gt; Anti-tampering</b>			
Anti-masking sensitivity (for each sensor)	Disabled, Low, Medium, High		High
Anti-masking distance (for each sensor)	200 mm	1000 mm	1000 mm
Anti-rotation around axes (for each sensor)	Disabled, Enabled		Disabled
Anti-rotation around axes - Enable specific axis - Tilt (for each sensor)	Disabled, Enabled		Disabled
Anti-rotation around axes - Enable specific axis - Roll (for each sensor)	Disabled, Enabled		Disabled
Anti-rotation around axes - Enable specific axis - Pan (for each sensor)	Disabled, Enabled		Disabled
<b>Settings &gt; Digital Input-Output</b>			
Digital input (for each input)	Not configured, Stop signal, Restart signal, Muting group “N”, Dynamic configuration switch, Fieldbus controlled, System recondition, Restart signal + System recondition, Single channel (Category 2)		Not configured
Digital input channel (for each channel of each input)	Not configured, Restart signal, Fieldbus controlled, System recondition		Not configured
Redundancy mode	Coherent, Inverted		Coherent

Parameter	Min	Max	Default value
Encoded channel	Enabled, Disabled <i>Note: available only when both the digital inputs are configured as Dynamic configuration switch</i>		Disabled
Digital output (for each output)	Not configured, System diagnostic signal, Muting enable feedback signal, Fieldbus controlled, Restart feedback signal, Detection signal "N", Static object detection feedback signal, Detection signal group 1, Detection signal group 2		Not configured
OSSD Pulse width	Short (300 $\mu$ s), Long (2 ms)		Short (300 $\mu$ s)
Short-circuit/Open circuit diagnostics	Enabled, Disabled		Disabled
<b>Settings &gt; Muting</b>			
Group for muting (for each sensor)	None, Group 1, Group 2, both		Group 1
Pulse width (for each input)	0 $\mu$ s (= Period and Phase shift disabled) 200 $\mu$ s	2000 $\mu$ s	0 $\mu$ s
Period (for each input)	200 ms	2000 ms	200 ms
Phase shift (for each input)	0.4 ms	1000 ms	0.4 ms
<b>Settings &gt; Restart function</b>			
Detection field 1, 2, 3, 4	Automatic, Manual, Safe manual		Automatic
<b>Settings &gt; Activity History</b>			
Log verbosity level	0	5	0
<b>Settings &gt; Detection field groups</b>			
Detection field 1, 2, 3, 4 (for each sensor)	None, Group 1, Group 2, Both		None
<b>Admin &gt; Network Parameters</b>			
IP Address	-		192.168.0.20
Netmask	-		255.255.255.0
Gateway	-		192.168.0.1
TCP port	1	65534	80
<b>Admin &gt; Fieldbus Parameters</b>			
System configuration and status PS2v6	1	65535	145
Sensors information PS2v6	1	65535	147
Sensor 1 detection status PS2v6	1	65535	149
Sensor 2 detection status PS2v6	1	65535	151
Sensor 3 detection status PS2v6	1	65535	153
Sensor 4 detection status PS2v6	1	65535	155
Sensor 5 detection status PS2v6	1	65535	157
Sensor 6 detection status PS2v6	1	65535	159
System configuration and status PS2v4	1	65535	146
Sensors information PS2v4	1	65535	148
Sensor 1 detection status PS2v4	1	65535	150
Sensor 2 detection status PS2v4	1	65535	152
Sensor 3 detection status PS2v4	1	65535	154
Sensor 4 detection status PS2v4	1	65535	156
Sensor 5 detection status PS2v4	1	65535	158
Sensor 6 detection status PS2v4	1	65535	160
Fieldbus endianness	Big Endian, Little Endian		Big Endian

Parameter	Min	Max	Default value
FSoE Safe Address	1	65535	145
<b>Admin &gt; MODBUS Parameters</b>			
MODBUS Enable	Enabled, Disabled		Enabled
Listening port	1	65534	502
<b>Admin &gt; System labels</b>			
Control unit	-		-
Sensor 1	-		-
Sensor 2	-		-
Sensor 3	-		-
Sensor 4	-		-
Sensor 5	-		-
Sensor 6	-		-
<b>Admin &gt; Users management</b>			
User name	-		-
Access level	Admin, Engineer, Expert, Observer, Service		Observer
<b>Admin &gt; SD Card</b>			
Automatic backup creation	Enabled, Disabled		Disabled
Users data included	Enabled, Disabled		Disabled
Enable restore by button	Enabled, Disabled		Enabled

## 11.5 Digital input signals

### 11.5.1 Stop signal

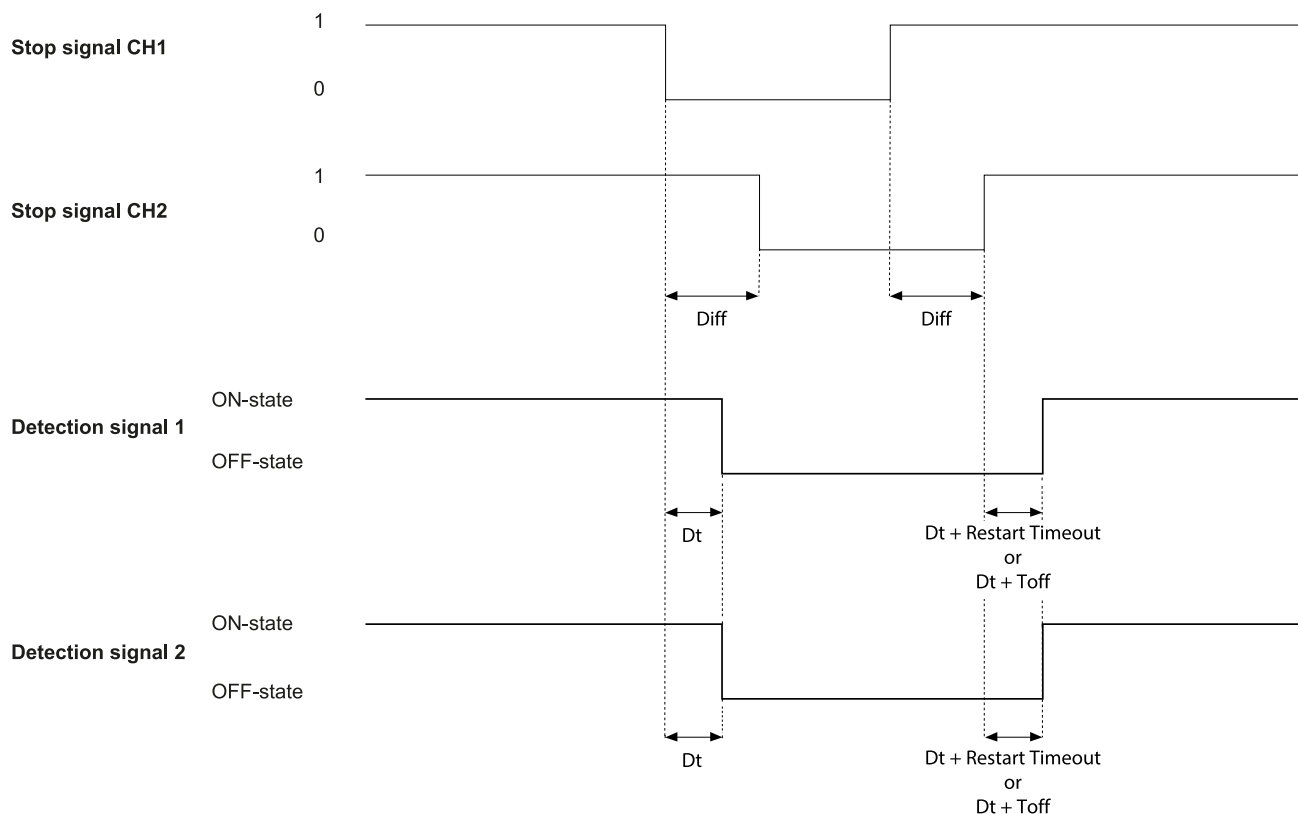

Part	Description
<b>Detection signal 1</b> <b>Detection signal 2</b>	Both deactivate on the falling edge of, at least, one of the two input channels of the input signal. They remain in OFF-state as long as one of the two input channels remains to the low logic status (0).
<b>Stop signal CH1</b> <b>Stop signal CH2</b>	Interchangeable channel. As soon as one channel goes to the low logic level (0), Detection signal 1 and Detection signal 2 are set to OFF-state.
<b>Diff</b>	Less than 50 ms. If the value is greater than 50 ms, the diagnostic alarm starts and the system deactivates the safety outputs.
<b>Dt</b>	Activation delay. Less than 5 ms.



## 11.5.2 Muting (with/without pulse)

### Without pulse (redundancy mode coherent)

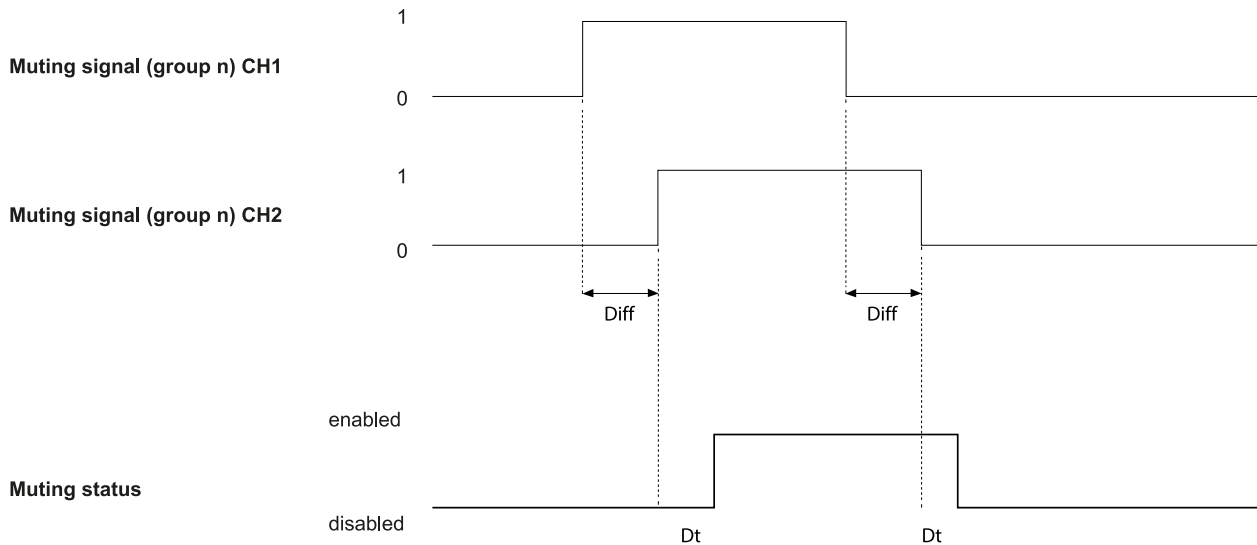

Part	Description
<b>Diff</b>	Less than 100 ms. If the value is greater than 100 ms, the diagnostic alarm starts and the system deactivates the safety outputs.
<b>Muting signal (group n) CH 1</b>	Interchangeable channel.
<b>Muting signal (group n) CH 2</b>	
<b>Muting status</b>	They are enabled as long as both channels are at a high logic level (1) and deactivated when both channels go to a low logic level (0).
<b>Dt</b>	Activation/deactivation delay. Less than 50 ms.

### Without pulse (redundancy mode inverted)

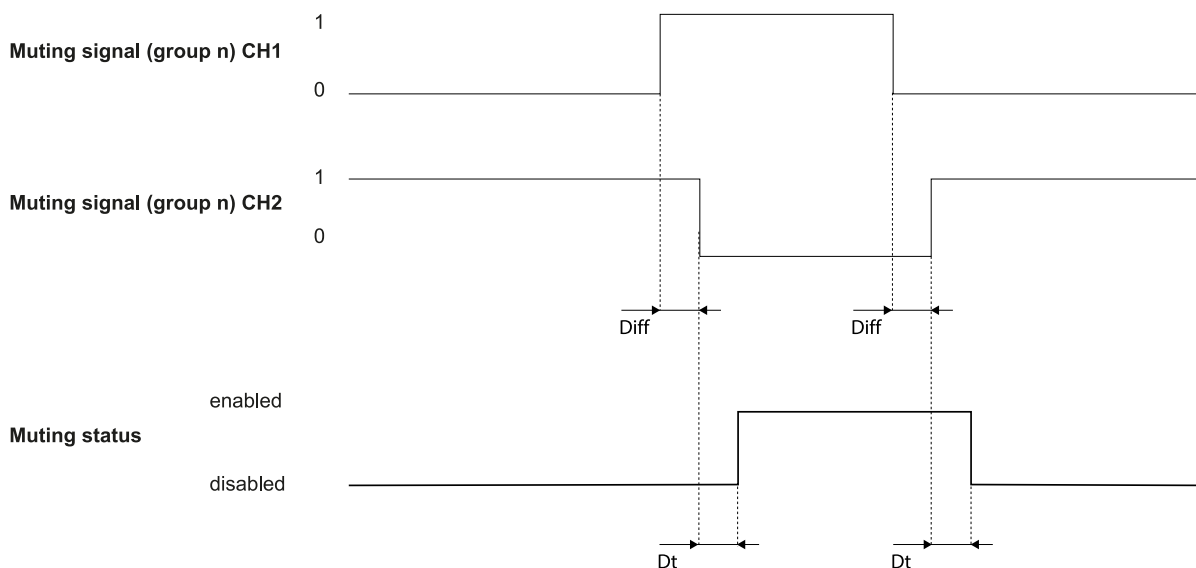

Part	Description
<b>Diff</b>	Less than 100 ms. If the value is greater than 100 ms, the diagnostic alarm starts and the system deactivates the safety outputs.
<b>Muting status</b>	They are enabled as long as channel 1 of the Muting signal is at a high logic level (1) and channel 2 is at a low logic level (0). Disabled as long as channel 1 is at a low logic level (0) and channel 2 is at a high logic level (1).

Part	Description
<b>Dt</b>	Activation/deactivation delay. Less than 50 ms.

**With pulse**

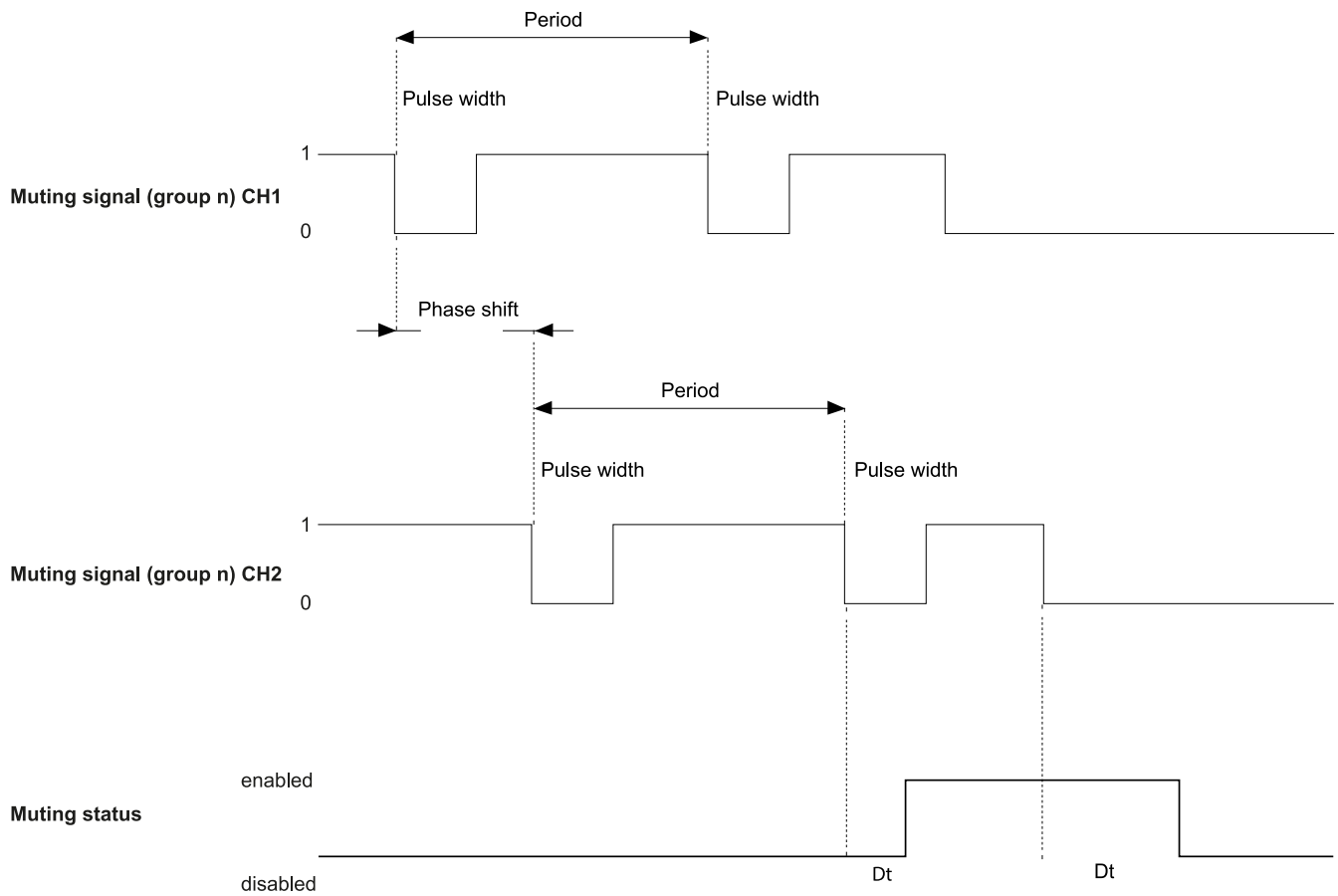

Part	Description
<b>Diff</b>	Less than 100 ms. If the value is greater than 100 ms, the diagnostic alarm starts and the system deactivates the safety outputs.
<b>Muting signal (group n) CH 1</b> <b>Muting signal (group n) CH 2</b>	Interchangeable channel.
<b>Muting status</b>	They are enabled as long as both the input signals follow the configured muting parameters (pulse width, period, and phase shift).
<b>Dt</b>	Activation/deactivation delay. Less than three times the period.

### 11.5.3 Restart signal (dual channel, redundancy mode coherent)

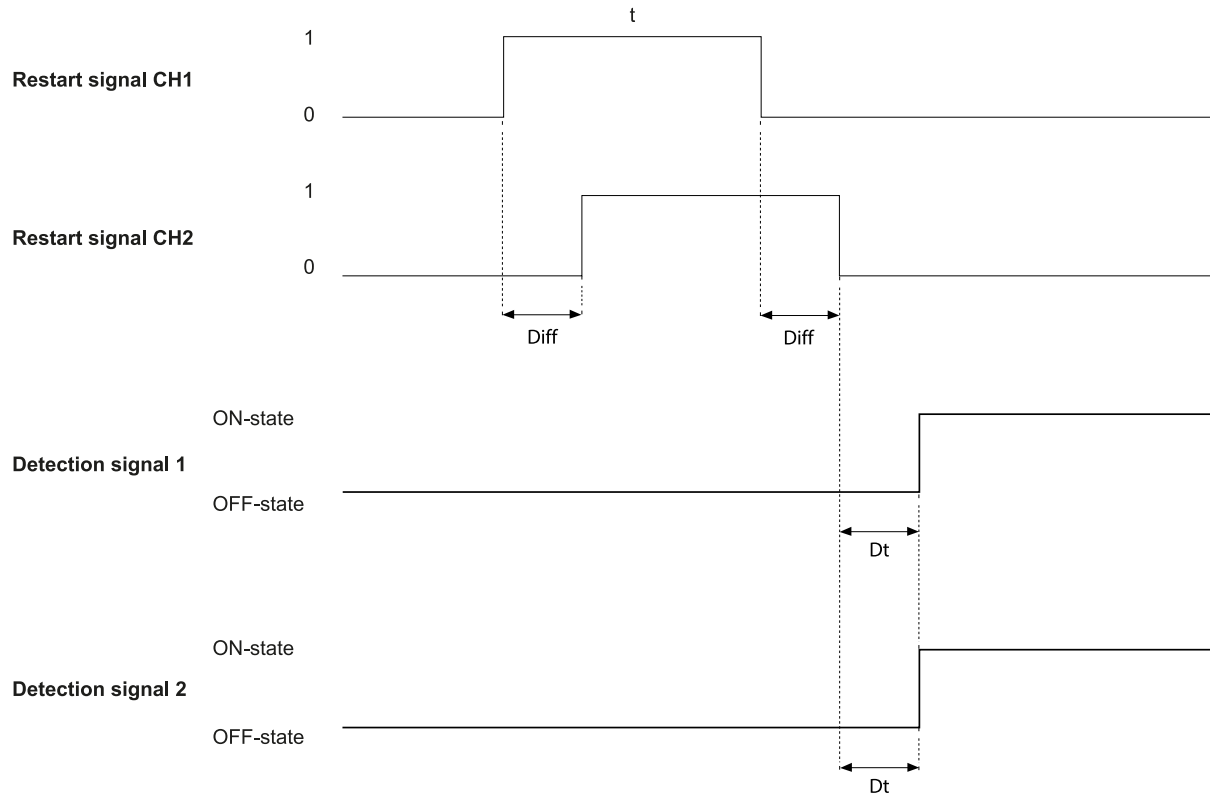

Part	Description
<b>Detection signal 1</b>	The Detection signal 1 and Detection signal 2 outputs go to ON-state as soon as the last channel has correctly completed the transition 0 -> 1 -> 0.
<b>Detection signal 2</b>	
<b>Restart signal CH1</b>	Interchangeable channel. Both channels of Restart signal must have a transition of logical level 0 -> 1 -> 0. The time they stay at a high logical level ( $t$ ) must be at least 200 ms and less than 5 s.
<b>Restart signal CH2</b>	
<b>Dt</b>	Activation delay. Less than 50 ms.
<b>Diff</b>	Less than 100 ms. If the value is greater than 100 ms, the system maintains the outputs deactivated.

### 11.5.4 Restart signal (dual channel, redundancy mode inverted)

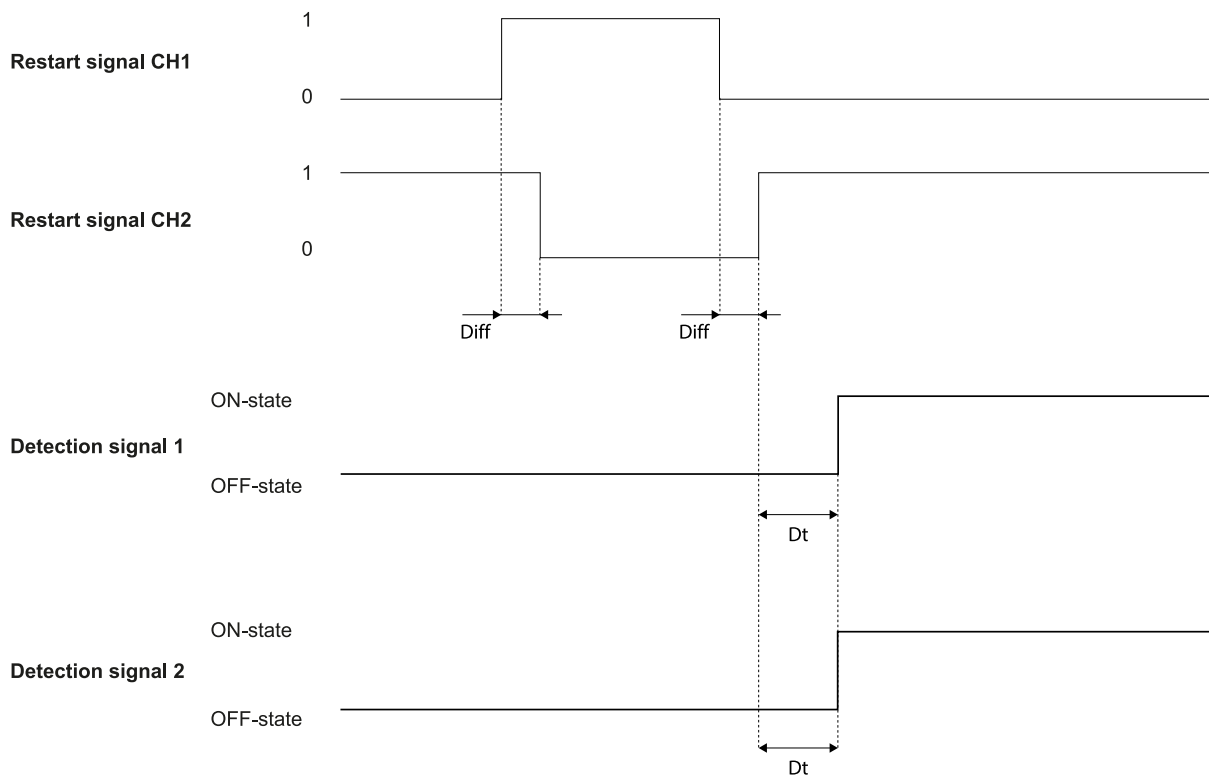

Part	Description
<b>Detection signal 1</b>	The Detection signal 1 and Detection signal 2 outputs go to ON-state as soon as the last channel has correctly completed the transition.
<b>Detection signal 2</b>	
<b>Restart signal CH1</b>	Channel 1 of the Restart signal must have a transition of logical level 0 -> 1 -> 0. Channel 2 of Restart signal must have a transition of logical level 1 -> 0 -> 1. The time they stay at a high logical level (t) must be at least 200 ms and less than 5 s.
<b>Restart signal CH2</b>	
<b>Dt</b>	Activation delay. Less than 50 ms.
<b>Diff</b>	Less than 100 ms. If the value is greater than 100 ms, the system maintains the outputs deactivated.

### 11.5.5 Restart signal (single channel)

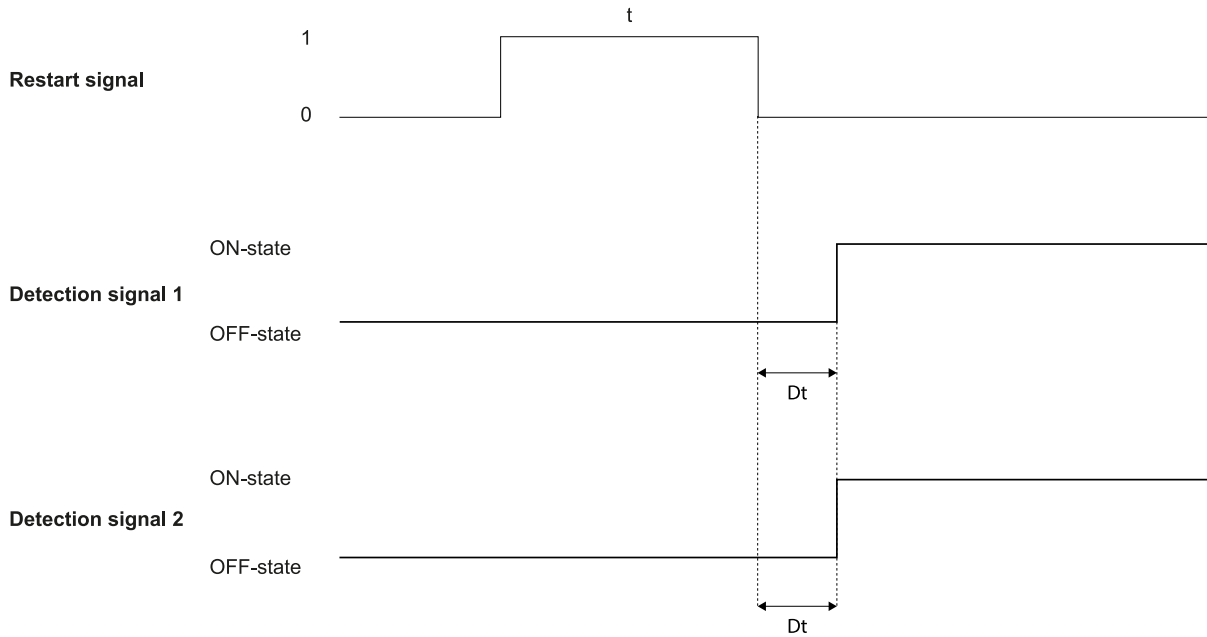

Part	Description
<b>Detection signal 1</b> <b>Detection signal 2</b>	The Detection signal 1 and Detection signal 2 outputs go to ON-state as soon as the Restart signal has correctly completed the transition 0 -> 1 -> 0.
<b>Restart signal</b>	The channel must have a transition of logical level 0 -> 1 -> 0. The time they stay at a high logical level ( $t$ ) must be at least 200 ms and less than 5 s.
<b>Dt</b>	Activation delay. Less than 50 ms.

### 11.5.6 System recondition (dual channel, redundancy mode coherent)

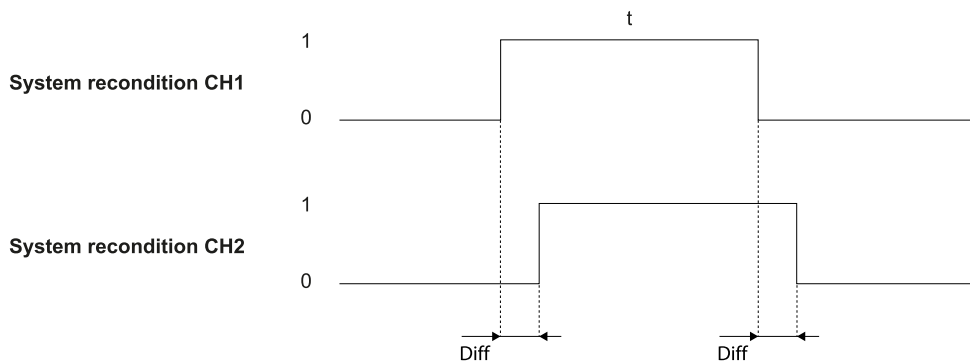

Part	Description
<b>System recondition CH1</b> <b>System recondition CH2</b>	Interchangeable channel. Both channels of System recondition must have a transition of logical level 0 -> 1 -> 0. They must stay at a high logical level ( $t$ ) for at least 10 s and less than 30 s.
<b>Diff</b>	Less than 100 ms. If the value is greater than 100 ms, the system maintains the outputs deactivated.

### 11.5.7 System recondition (dual channel, redundancy mode inverted)

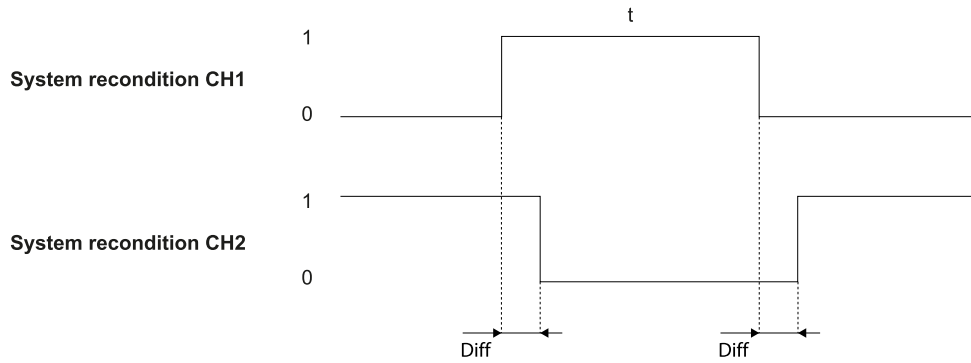

Part	Description
<b>System recondition CH1</b>	Channel 1 of System recondition must have a transition of logical level 0 -> 1 -> 0. Channel 2 of System recondition must have a transition of logical level 1 -> 0 -> 1. They must stay at a high logical level (t) for at least 10 s and less than 30 s.
<b>System recondition CH2</b>	
<b>Diff</b>	Less than 100 ms. If the value is greater than 100 ms, the system maintains the outputs deactivated.

### 11.5.8 System recondition (single channel)

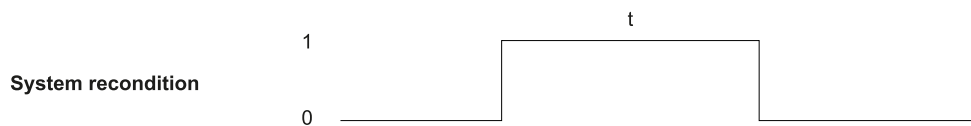

Part	Description
<b>System recondition</b>	The channel must have a transition of logical level 0 -> 1 ->0. The time it stays at a high logical level (t) must be at least 10 s and less than 30 s.

### 11.5.9 Restart signal + System recondition (dual channel, redundancy mode coherent)

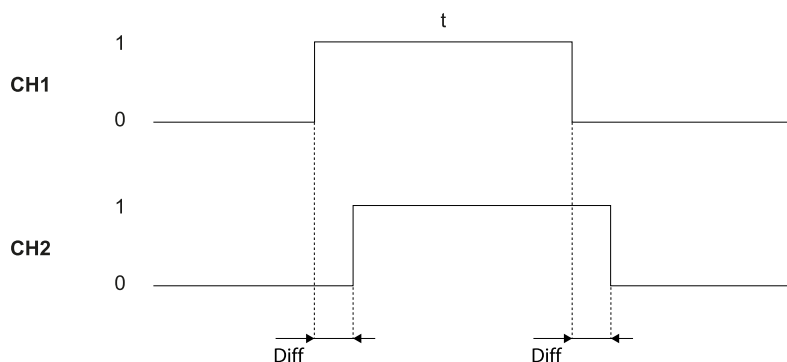

Part	Description
<b>CH1</b> <b>CH2</b> <b>(Restart signal)</b>	Interchangeable channel. Both channels must have a transition of logical level 0 -> 1 ->0. The time they stay at a high logical level (t) must be at least 200 ms and less than 5 s. For details about the behavior of Detection signal 1 and 2 outputs and the deactivation delay, see "Restart signal (dual channel, redundancy mode coherent)" on page 123
<b>CH1</b> <b>CH2</b> <b>(System recondition)</b>	Interchangeable channel. Both channels must have a transition of logical level 0 -> 1 ->0. They must stay at a high logical level (t) for at least 10 s and less than 30 s.

Part	Description
<b>Diff</b>	Less than 100 ms. If the value is greater than 100 ms, the system maintains the outputs deactivated.

### 11.5.10 Restart signal + System recondition (dual channel, redundancy mode inverted)

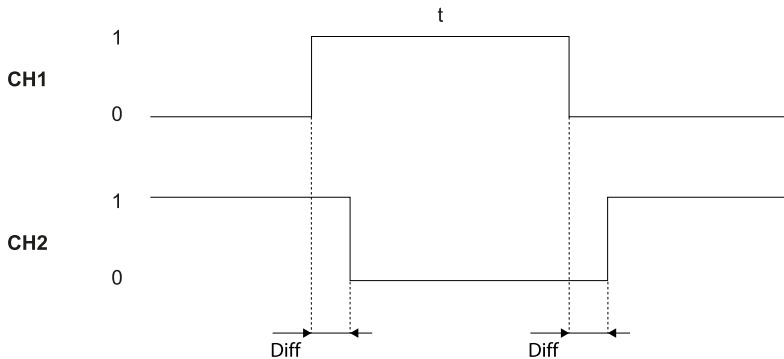

Part	Description
<b>CH1</b> <b>CH2</b> <b>(Restart signal)</b>	Channel 1 of the Restart signal must have a transition of logical level 0 -> 1 -> 0. Channel 2 of Restart signal must have a transition of logical level 1 -> 0 -> 1. The time they stay at a high logical level (t) must be at least 200 ms and less than 5 s. For details about the behavior of Detection signal 1 and 2 outputs and the deactivation delay, see "Restart signal (dual channel, redundancy mode inverted)" on page 124
<b>CH1</b> <b>CH2</b> <b>(System recondition)</b>	Channel 1 of System recondition must have a transition of logical level 0 -> 1 -> 0. Channel 2 of System recondition must have a transition of logical level 1 -> 0 -> 1. They must stay at a high logical level (t) for at least 10 s and less than 30 s.
<b>Diff</b>	Less than 100 ms. If the value is greater than 100 ms, the system maintains the outputs deactivated.

### 11.5.11 Restart signal + System recondition (single channel)



Part	Description
<b>Restart signal</b>	The channel must have a transition of logical level 0 -> 1 ->0. The time it stays at a high logical level (t) must be at least 200 ms and less than 5 s. For details about the behavior of Detection signal 1 and 2 outputs and the deactivation delay, see "Restart signal (single channel)" on page 125
<b>System recondition</b>	The channel must have a transition of logical level 0 -> 1 ->0. The time it stays at a high logical level (t) must be at least 10 s and less than 30 s.

### 11.5.12 Dynamic configuration switch (redundancy mode coherent)

#### With one input

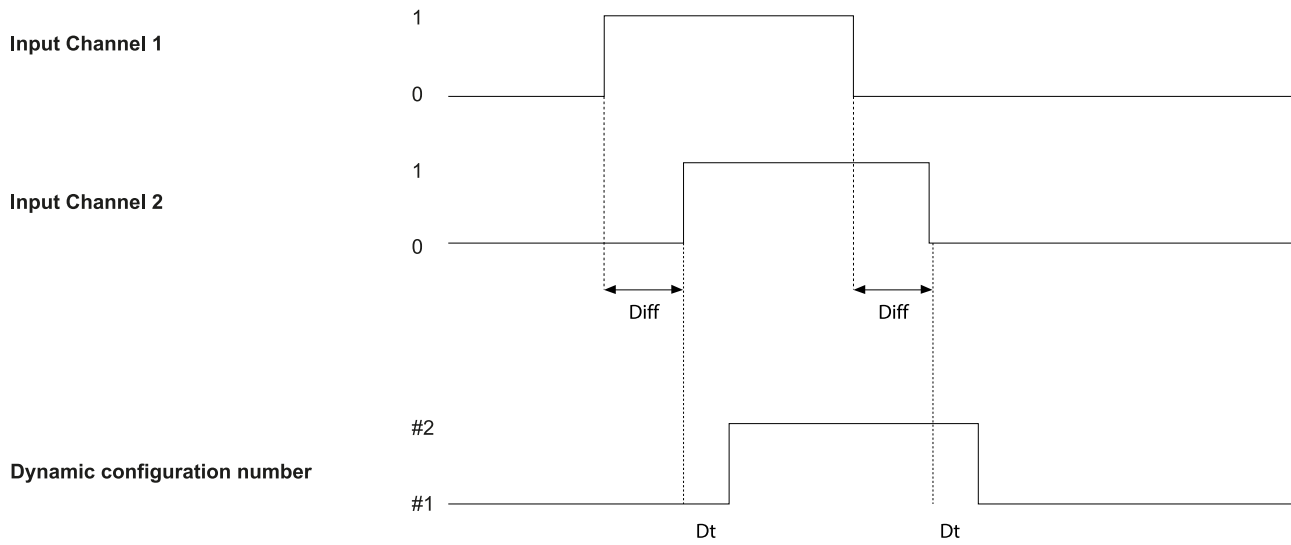

#### With two inputs (encoded channels disabled)

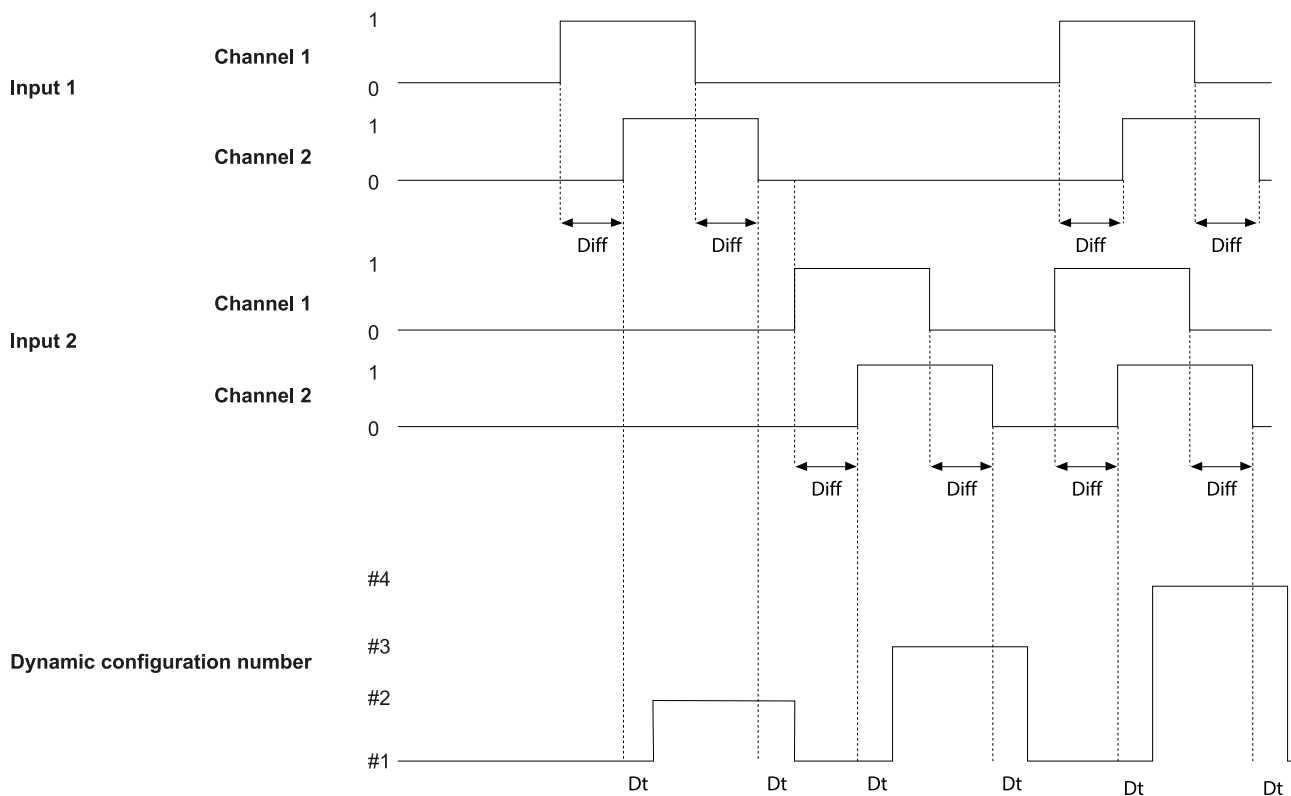

Part	Description
<b>Diff</b>	Less than 100 ms. If the value is greater than 100 ms, the diagnostic alarm starts and the system deactivates the safety outputs.
<b>Dynamic configuration number</b>	For details about the dynamic configuration number and the encoded channel option, see "Dynamic configuration through the digital inputs" on page 35.
<b>Dt</b>	Activation/deactivation delay. Less than 50 ms.



### 11.5.13 Dynamic configuration switch (redundancy mode inverted)

#### With one input

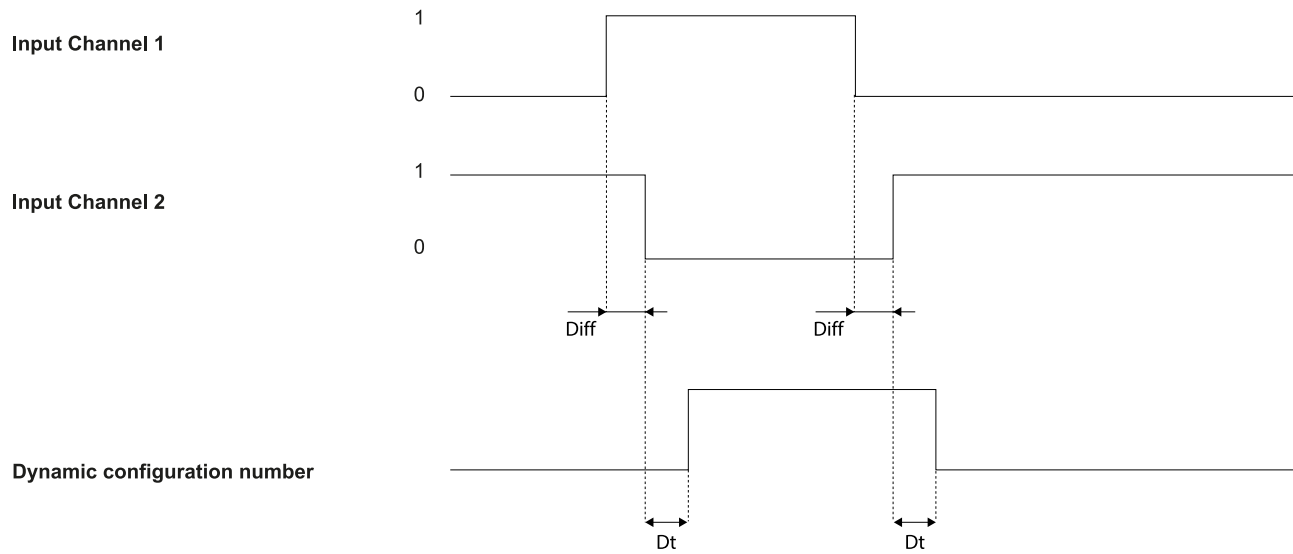

#### With two inputs

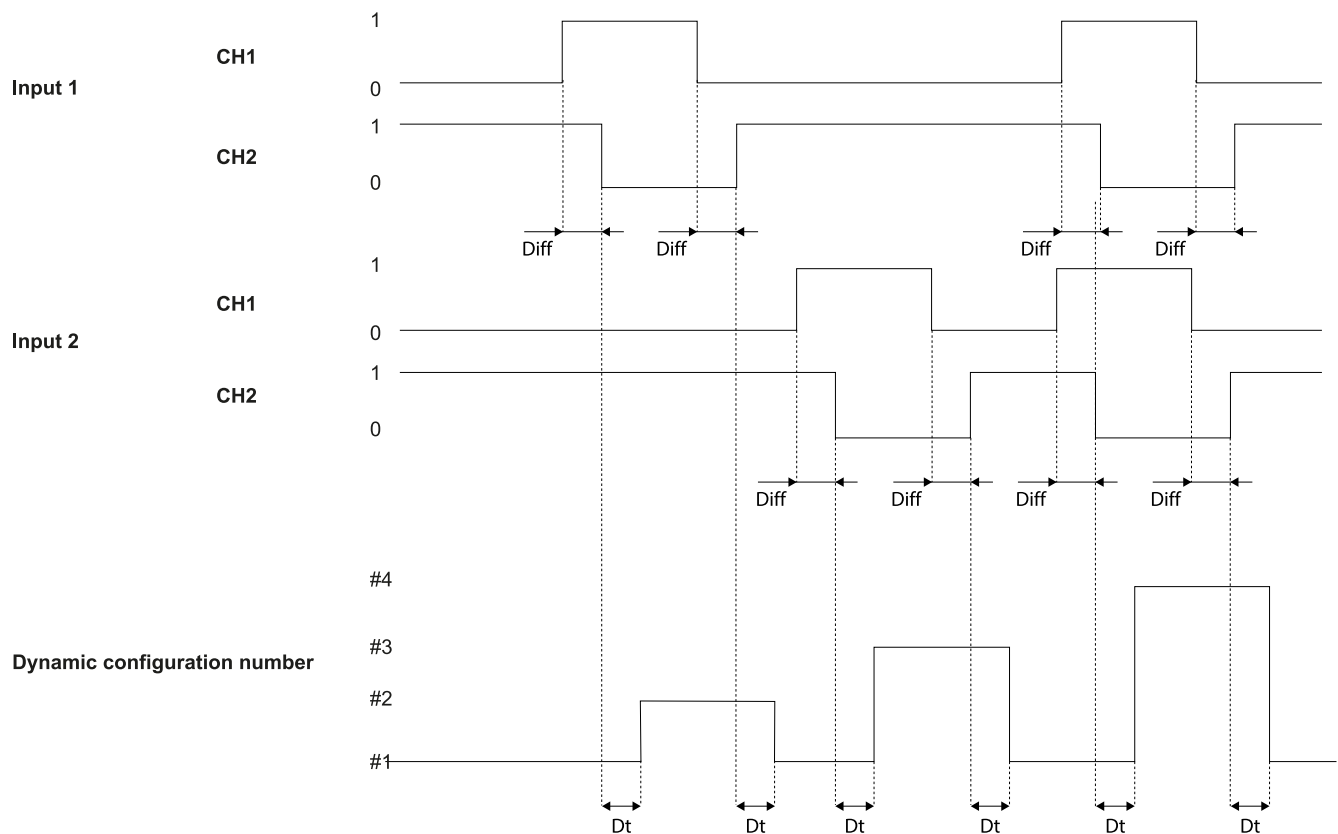

Part	Description
<b>Diff</b>	Less than 100 ms. If the value is greater than 100 ms, the diagnostic alarm starts and the system deactivates the safety outputs.
<b>Dynamic configuration number</b>	For details about the dynamic configuration number and the encoded channels option, see "Dynamic configuration through the digital inputs" on page 35
<b>Dt</b>	Activation/deactivation delay. Less than 50 ms.

# 12. Appendix

---

## Contents

This section includes the following topics:

<b>12.1 System software</b> .....	<b>130</b>
<b>12.2 Disposal</b> .....	<b>131</b>
<b>12.3 Service and warranty</b> .....	<b>131</b>
<b>12.4 Intellectual property</b> .....	<b>132</b>
<b>12.5 Checklist for installing ESPE</b> .....	<b>132</b>

## 12.1 System software

---

### 12.1.1 Introduction

The aim of this appendix is to provide and clarify the information related to the system software. It includes the information necessary for the integrator during the installation and integration in accordance with IEC 61508-3 Annex D.

Considering that Inxpect SRE 200 Series is an embedded system provided with a firmware already deployed on board, no software integration is required by the system installer or by the end user. The following paragraphs analyzes all the information required in IEC 61508-3 Annex D.

### 12.1.2 Configuration

The system configuration can be performed by means of a PC-based configuration tool, called the Inxpect Safety application.

The system configuration is described in "Installation and use procedures" on page 65.

### 12.1.3 Competence

Although no competence is required for software integration, a skilled person is required for system installation and configuration, as described in "Installation and use procedures" on page 65.

### 12.1.4 Installation instructions

The firmware is already deployed on the hardware, the PC-based configuration tool includes a self-explanatory setup installer.

### 12.1.5 Outstanding anomalies

At the moment of the issue of this document, no software/firmware anomalies or bugs are known.

### 12.1.6 Backward compatibility

Backward compatibility is guaranteed.

### 12.1.7 Change control

Any change proposal suggested by the integrator or the end user should be forwarded to Inxpect and evaluated by the Product Owner.

### 12.1.8 Implemented security measures

Firmware upgrade packages are managed by the Inxpect Technical Support and are signed to prevent the use of unverified binary files.

## 12.2 Disposal



Inxpect SRE 200 Series contains electrical parts. As set forth in European Directive 2012/19/EU, do not dispose of the product with unsorted urban waste materials.



It is the responsibility of the owner/distributor to dispose of these products, as well as other electrical and electronic equipment, through specific waste collection facilities indicated by the waste disposal services.

Correct disposal and recycling will contribute to the prevention of potentially harmful consequences to the environment and human health.

For more detailed information about disposal, contact the waste disposal services or the representative from whom you purchased the product.

## 12.3 Service and warranty

### 12.3.1 Technical Support

Inxpect SpA  
Via Serpente, 91  
25131 Brescia (BS) - Italy  
Tel: +39 030 5785105  
email: [safety-support@inxpect.com](mailto:safety-support@inxpect.com)  
website: [www.inxpect.com](http://www.inxpect.com)

### 12.3.2 How to return the product

If necessary, complete the request with information about the return on the website [www.inxpect.com/industrial/rma](http://www.inxpect.com/industrial/rma). Then, return the product to the local distributor or exclusive distributor. **Use the original packaging. Shipping costs are at the customer's expense.**

Area distributor	Manufacturer
<i>Note distributor information here:</i>	Inxpect SpA Via Serpente, 91 25131 Brescia (BS) Italy <a href="http://www.inxpect.com">www.inxpect.com</a>

### 12.3.3 Service and warranty

Refer to [www.inxpect.com](http://www.inxpect.com) for the following information:

- terms, exclusions and cancellation of the warranty
- general conditions of the Return Merchandise Authorization (RMA)

## 12.4 Intellectual property

### 12.4.1 Trademarks

EtherCAT® and Safety over EtherCAT® are registered trademarks and patented technologies licensed by Beckhoff Automation GmbH, Germany.

## 12.5 Checklist for installing ESPE

### 12.5.1 Introduction

Collecting the details relating to the following items is mandatory no later than when the system is commissioned for the first time.

This checklist should be kept with the machine documentation to serve as a reference during periodic tests.

This checklist does not replace the initial commissioning or regular inspection by qualified safety personnel.

### 12.5.2 Checklist

Question	Yes	No
Have the safety rules and regulations been observed in compliance with the directives and standards applicable to the machine?		
Are the applied directives and standards listed in the declaration of conformity?		
Does the ESPE comply with the required PL/SIL claim limit and PFHD in accordance with EN ISO 13849-1/EN 62061 and the required type in accordance with EN 61496-1?		
Is access to the dangerous area only possible through the detection field of the ESPE?		
Have appropriate measures been taken to detect any persons in the dangerous area?		
Have the safety devices been secured or locked to prevent their removal?		
Are additional mechanical protective measures fitted and secured against manipulation which prevent reaching below, above, or around the ESPE?		
Has the maximum stopping time of the machine been measured, specified, and documented?		
Has the ESPE been mounted such that the required minimum distance from the nearest hazardous point has been achieved?		
Are the ESPE devices properly mounted and secured against manipulation after adjustment?		
Are the required protective measures against electric shock in effect (protection class)?		
Is the control switch for resetting the protective devices (ESPE) or restarting the machine present and correctly installed?		
Are the outputs of the ESPE integrated according to the required PL/SIL in accordance with EN ISO 13849-1/EN 62061, and does the integration correspond to the circuit diagrams?		
Has the protective function been checked in compliance with the test notes of this documentation?		
Are the specified protective functions effective at every operating mode that can be set?		
Does the ESPE activate the switching elements?		
Is the ESPE effective over the entire period of the dangerous state?		
Once initiated, will a dangerous state be stopped when switching the ESPE on or off, when changing the operating mode, or when switching to another protective device?		



