

SM23165D		
Continuous Torque	2.50	in-lb
	40	oz-in
	0.28	N-m
Peak Torque	4.00	in-lb
	64	oz-in
	0.45	N-m
Nominal Continuous Power	181	Watt
No Load Speed	10,400	RPM
Max. Continuous Current* @ 6500 RPM	4.70	Amps
Peak Power @ 6100 RPM	183	Watts
Voltage Constant	4.45	V/kRPM
Inductance	0.829	mH
Encoder Resolution	4,000	Counts/Rev
Rotor Inertia	0.00099	oz-in-sec ²
	0.6991	10 ⁻⁵ Kg-m ²
Weight	1.0	lb
	0.45	kg
Shaft Diameter	0.250	in
	6.35	mm
Shaft, Radial Load	7	lb
	3.18	kg
Shaft, Axial Thrust Load	3	lb
	1.36	kg
DeviceNet Available	Yes	
PROFIBUS Available	Yes	
CANopen Available	Yes	

*Default voltage is 48V. See graphs for additional voltages.

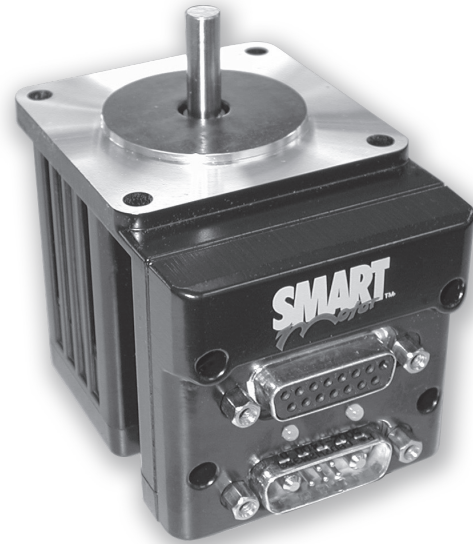

Operating temperature range: 0°C–85°C

Storage temperature range: -10°C–85°C, noncondensing

NOTE: Motor specifications are subject to changes without notice. Consult website and factory for latest data.



Moog Animatics SmartMotor™ SM23165D (No Options) CAD Drawing

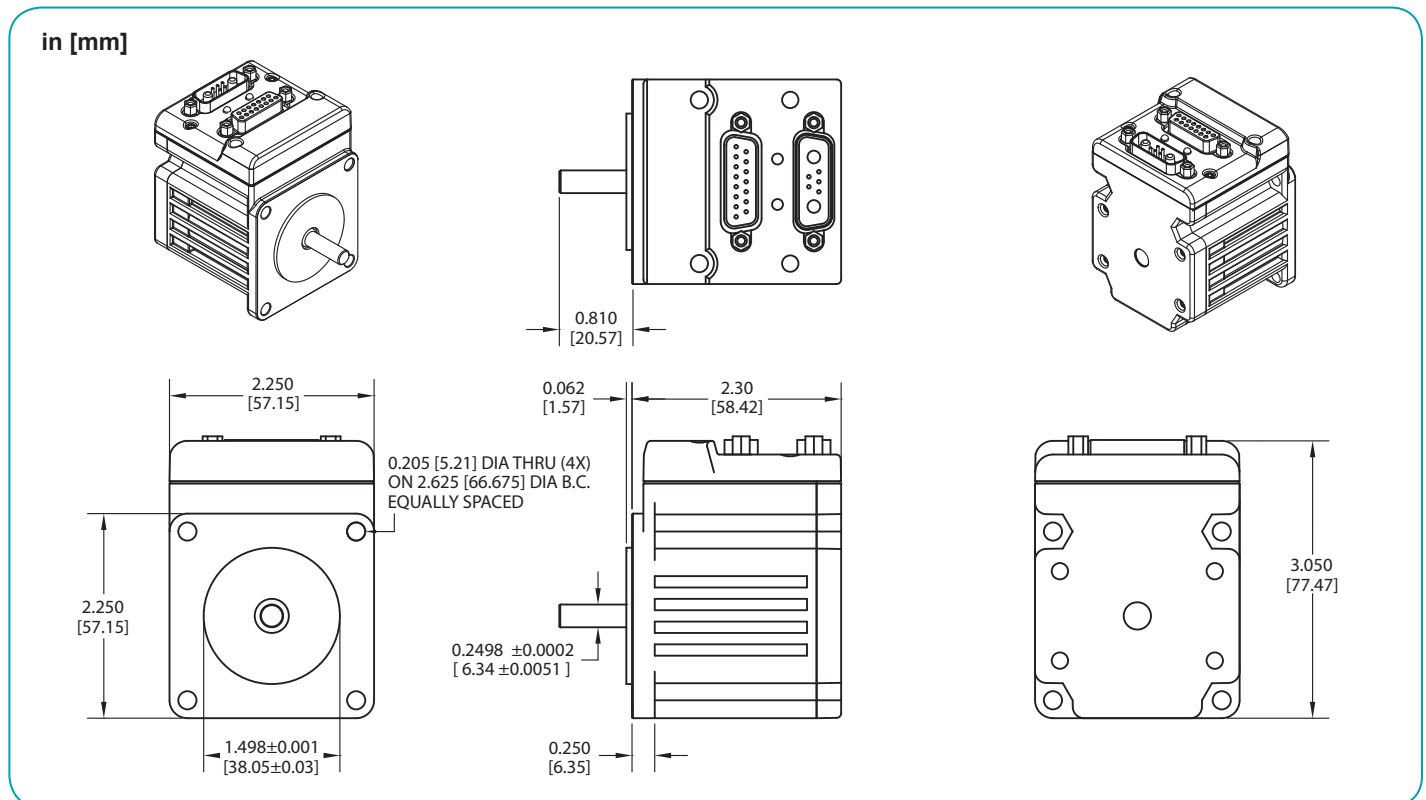

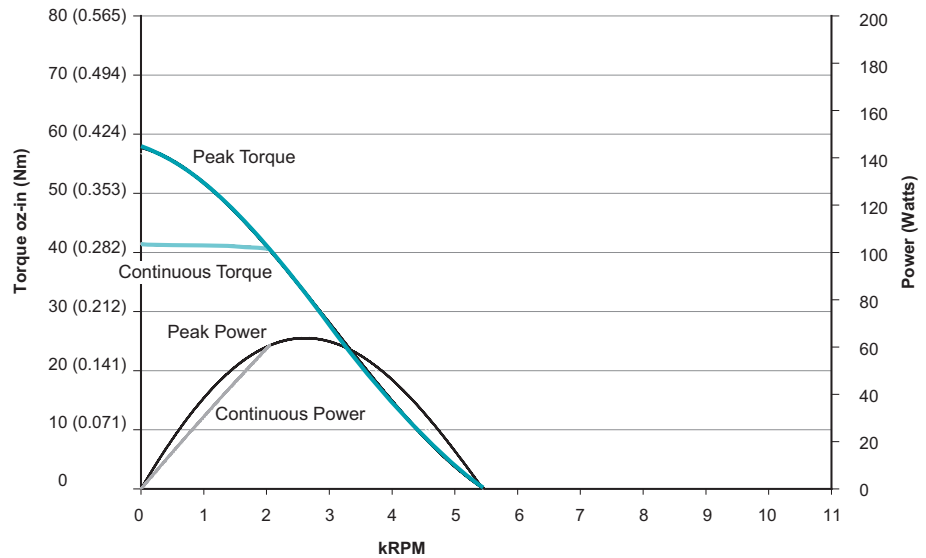
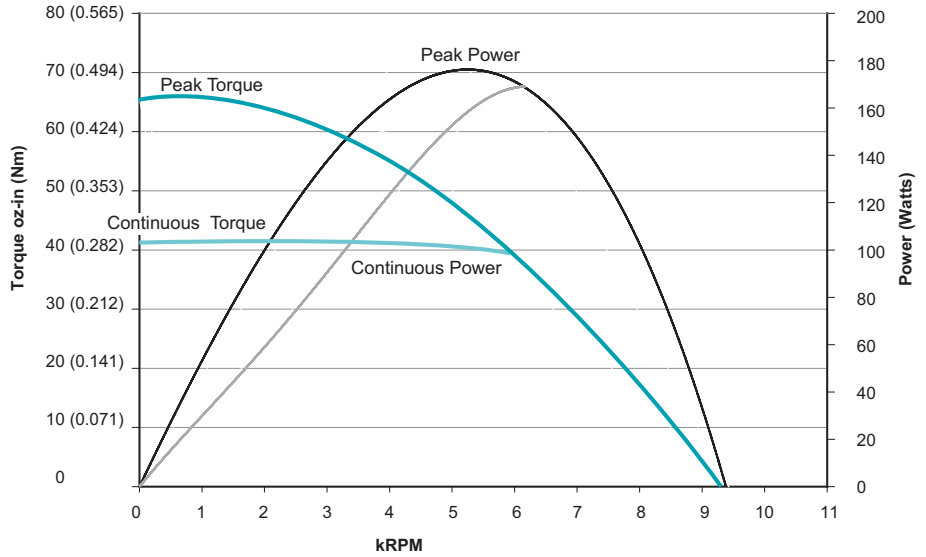
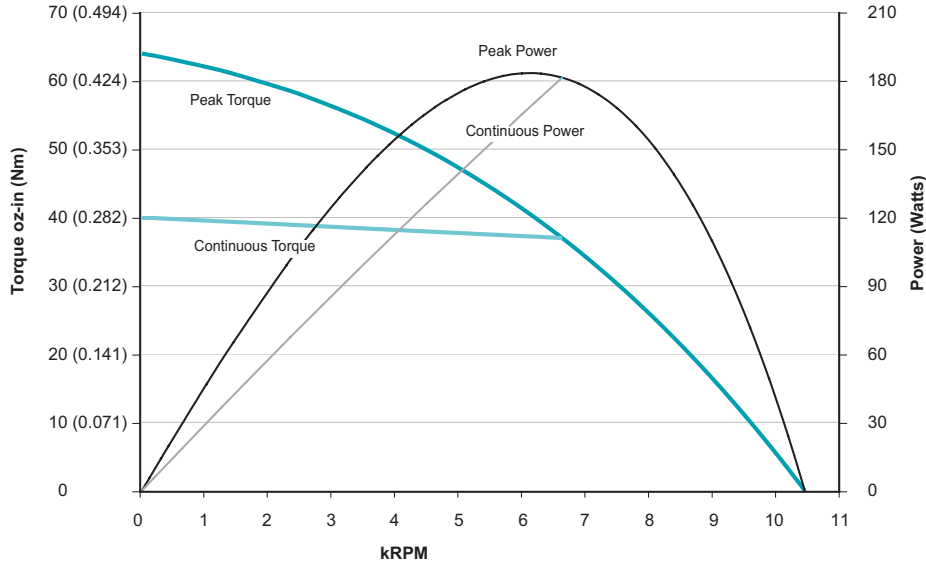

All torque curves based on 25°C ambient. Motors were operated using MDT (Trapezoidal Drive Mode) Commutation. For ambient temperatures above 25°C, Continuous Torque must be linearly derated to 0% at 85°C.